



800 SERIES
804D LOW PROFILE DEEP CEILING
INSTALLATION INSTRUCTIONS



SCAN QR CODE FOR INSTRUCTIONS

WARNING: Read and understand these instructions completely before installation. To be installed by qualified electricians only. Products should be installed in accordance with these instructions, local electrical codes, and the National Electric Code (NEC). These products may represent a possible shock or fire hazard if improperly installed.

CAUTION: Disconnect power at circuit breaker or fuse panel before installation or servicing. Always allow LED assembly to cool before servicing. Do not connect or disconnect LED lamp module wire connector when fixture is energized as this may result in permanent damage to the LED. Do not install where insulation or ambient temperatures will exceed maximum values noted in product specifications. Do not install in steam showers.

NOTE: Number Eight Lighting fixtures are designed to meet the latest NEC requirements and are listed in full compliance with UL standards. Before attempting installation, check your local electrical code which sets the wiring standards and installation requirements for your locality and should be understood before starting work.

SAVE THESE INSTRUCTIONS.

TABLE OF CONTENTS

	PAGE
HOUSING INSTALLATION - BAR HANGER MOUNTING.....	1-2
HOUSING INSTALLATION - PANEL MOUNTING BRACKET.....	3
HOUSING INSTALLATION - T-BAR MOUNTING.....	4
HOUSING INSTALLATION - BUTTERLY BRACKET MOUNTING.....	5
CEILING CUT-OUTS - PLASTER/SHEETROCK CEILINGS.....	6
LAMP MODULE INSTALLATION, ADJUSTMENT, REMOVAL.....	7-11
POWER SUPPLY REMOVAL AND REPLACEMENT.....	12
WIRING INSTRUCTIONS - SINGLE LAMP.....	13-17
WIRING INSTRUCTIONS - SINGLE LAMP TUNABLE WHITE.....	18-20

HOUSING INSTALLATION

Ceiling Information

Important: Designed for use with BASWA Acoustic 30mm thick ceiling systems or similar. Use with **800 Series Round FR-P-1 and FR-P-2** or Square **FS-P-1 and FS-P-2** flangeless trims for plaster/sheetrock applications. Accommodates 1-1/8" minimum to 1-1/2" maximum ceiling thicknesses.

Bar Hanger Mounting

STEP 1 Loosen 2 screws slightly on Housing to attach or adjust each Bar Hanger Bracket. Position Bar Hanger Bracket in hole position #1 & secure screws – **FIG 1.1 & 1.2**.

STEP 2 Assemble Hanger Bar A & B through each Bar Hanger Bracket to slide onto each other. The ends should have 1" minimum overlap.

Note: Bar Hangers can be shortened at break locations shown – **FIG 1.1**.

End Mounting

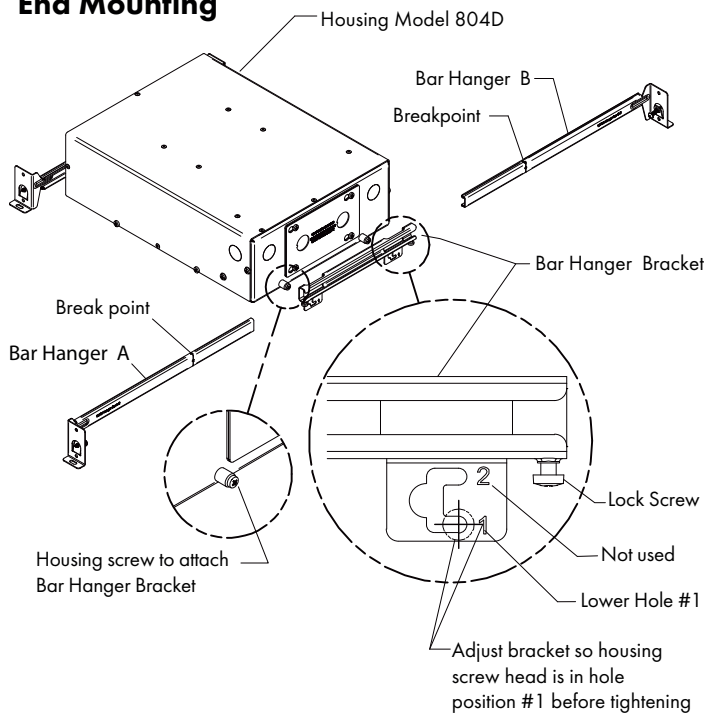

Side Mounting

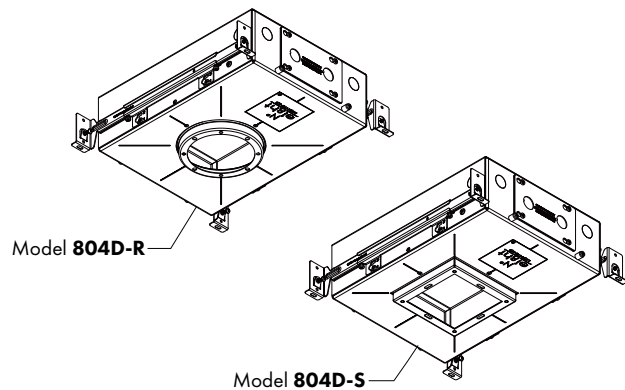

IMPORTANT:

Install so Bar Hanger flanges are positioned as shown

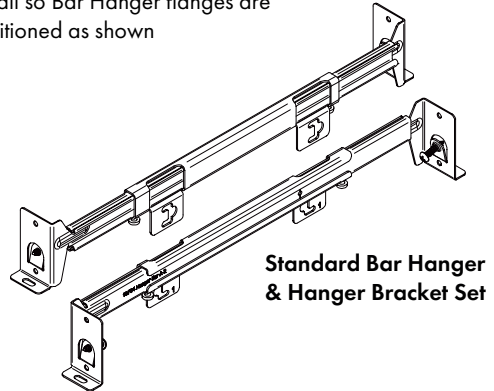

Standard Bar Hanger & Hanger Bracket Set

Hole Position Lower Hole #1

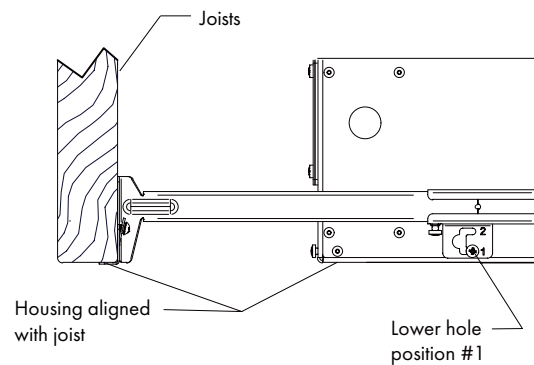

CAUTION:

Be sure to select correct hole position for intended Trim assembly. Changing hole position is not possible after ceiling is installed.

FIG 1.1 Installing Bar Hanger Hanger Bracket Set

FIG 1.2 Hole Position & Housing Location

HOUSING INSTALLATION

MOUNTING HOUSING TO JOISTS

STEP 1 Spread Hanger Bars to approximate joist spacing. Temporarily secure Lock Screws to keep Housing from sliding along Hanger Bars – **FIG 2.1 & 2.2.**

Note: For Sloped Ceilings - Installing Housing so J Box Cover faces wall is recommended for maximum adjustment on applicable Lamp Modules – **FIG 2.3.**

STEP 2 Secure Housing & Hanger Bar assembly to Joists using either the fasteners supplied on Hanger Bars or fasteners through alternate mounting holes – **FIG 2.1.**

STEP 3 Reposition Housing along Hanger Bars as needed. Use guide lines to help locate Housing relative to nearby walls or other fixtures – **FIG 2.1 & 2.2.**

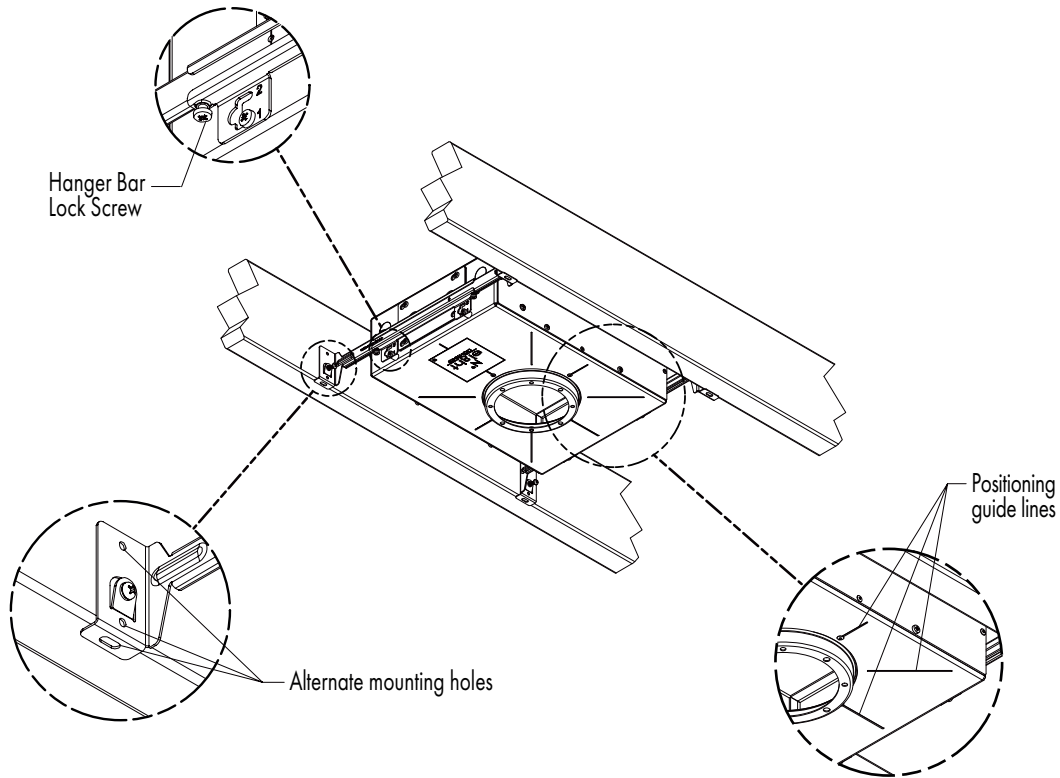

FIG 2.1 Fastening Housing to joists

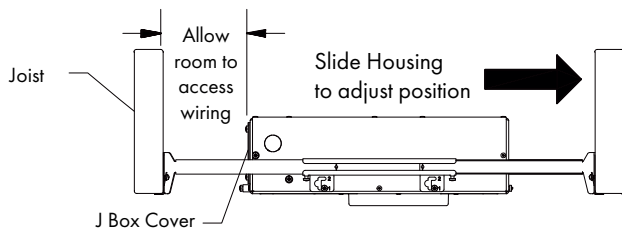

FIG 2.2 Horizontal Housing adjustment

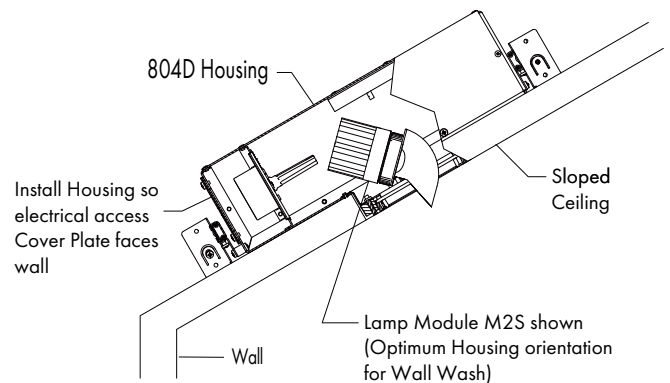

FIG 2.3 Recommended Sloped Ceiling Orientation

HOUSING INSTALLATION

PMB - Panel Mounting Brackets

CAUTION: Read all instructions completely before proceeding.

Note: Panel may consist of wood or other structural material. Sheetrock could also be used attached below panel & must be considered part of the overall ceiling thickness.

STEP 1 Loosen 2 screws slightly on Housing to attach or adjust each panel Mounting Bracket. Position Panel Mounting Bracket in hole position #1 & secure screws - **FIG 3.1.** & **FIG 3.2.**

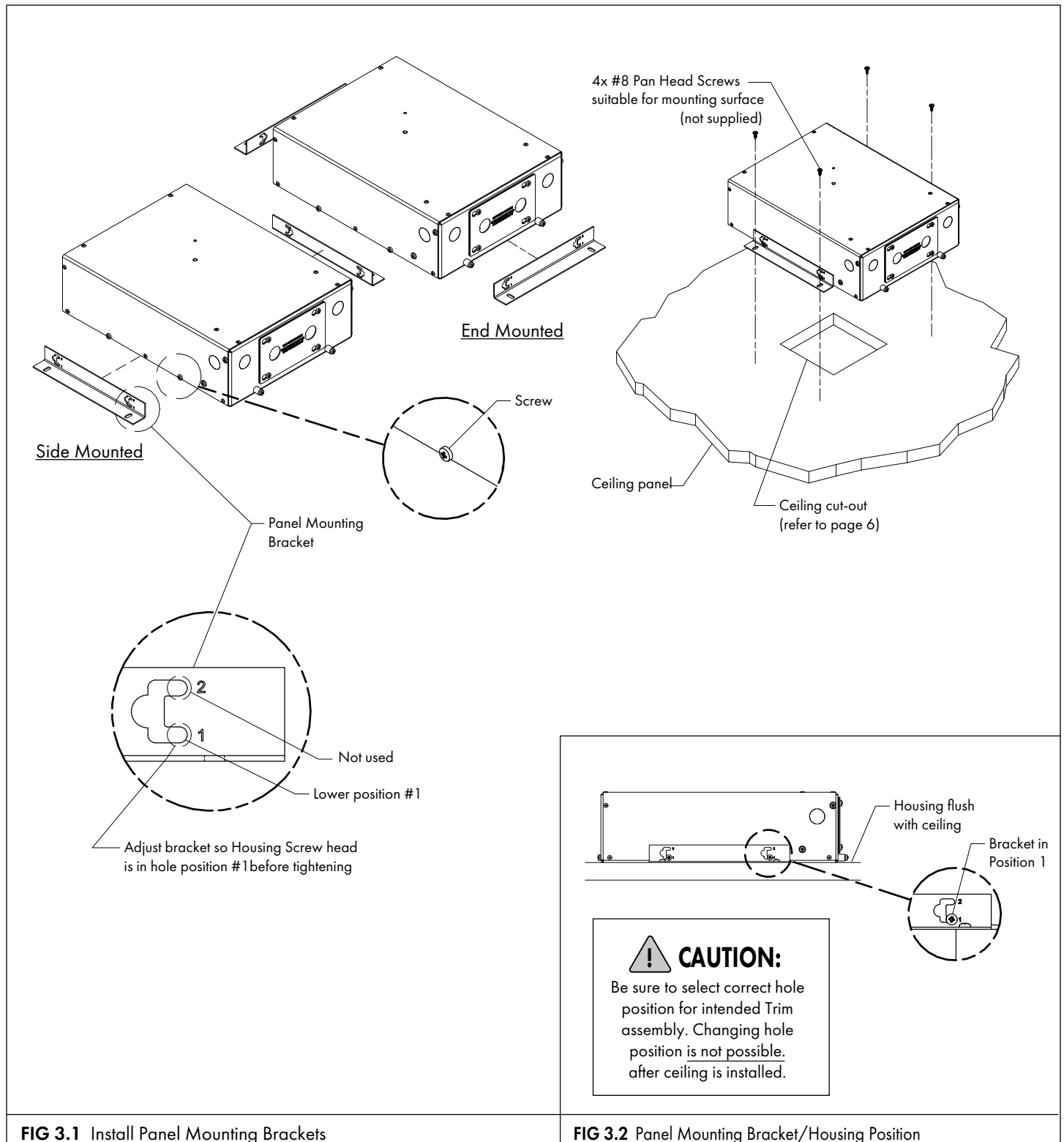

HOUSING INSTALLATION

TBC - T-Bar Clips for T-GRID MOUNTING with Bar Hangers

IMPORTANT: Use Bar Hanger Hole Position # 1.

CAUTION: Hanger Bar Hole position cannot be changed after ceiling is installed.

STEP 1 Pre-assemble T-Grid Clips to Bar Hangers & tighten Bar Hanger Mounting Screws just enough to allow for vertical adjustment of Hanger Bracket - **FIG 4.1**.

STEP 2 Attach Bar Hanger Brackets to Housing in hole position #1 - **FIG 4.2**.

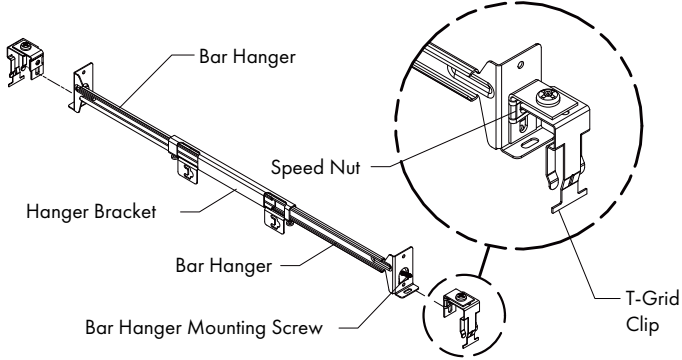

FIG 4.1 Attach T-Grid Clip assemblies to Hanger Bracket Assemblies

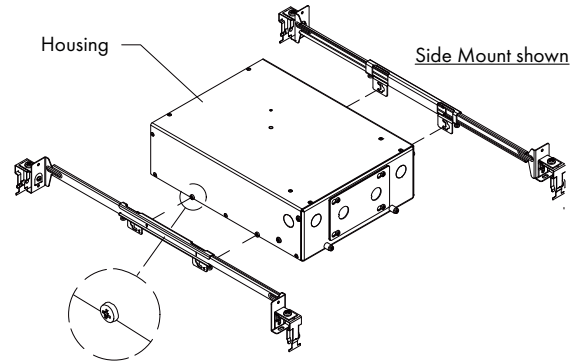

FIG 4.2 Attach Hanger Bracket Assemblies to Housing

STEP 3 Extend Bar Hangers to position T-Grid Clip assemblies fixture onto T-Grid bars - **FIG 4.5**.

Determine cut-out location in Ceiling Tile and ensure sufficient clearance for housing installation.

STEP 4 Cut opening in ceiling tile for Trim. For cut-out size, refer to Installation Instructions referenced above. Install Ceiling Tile into T-Grid - **FIG 4.4**.

Attach fixture to T-Grid so Trim fits into Ceiling Tile opening. Adjust fixture's horizontal position & lock into place by tightening the Hanger Bar Lock Screws - **FIG 4.5**.

STEP 5 Adjust vertical height of Housing by sliding speed nuts so Housing is level with Ceiling Tile. Lock position by tightening Mounting Screws - **FIG 4.6**.

Note: Trim will permit a vertical adjustment range to help accommodate Ceiling Tile thickness.

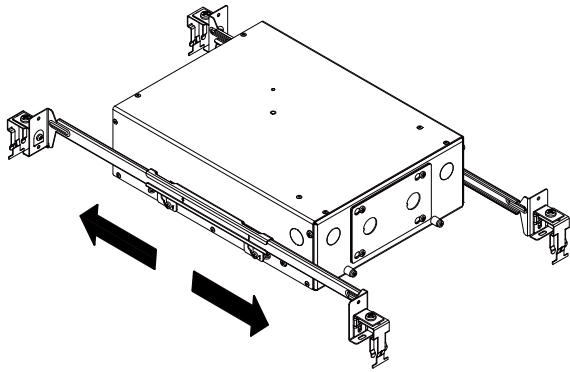

FIG 4.3 Adjust Bar Hangers

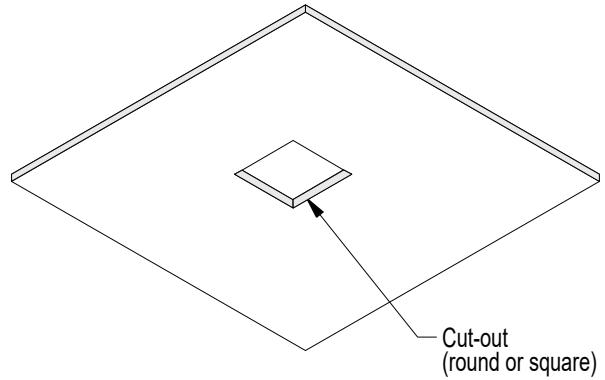

FIG 4.4 Cut opening in Ceiling Tile

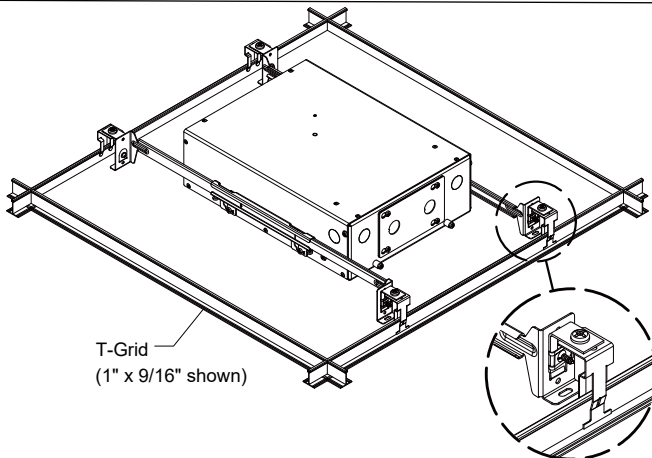

FIG 4.5 Attach to T-Grid

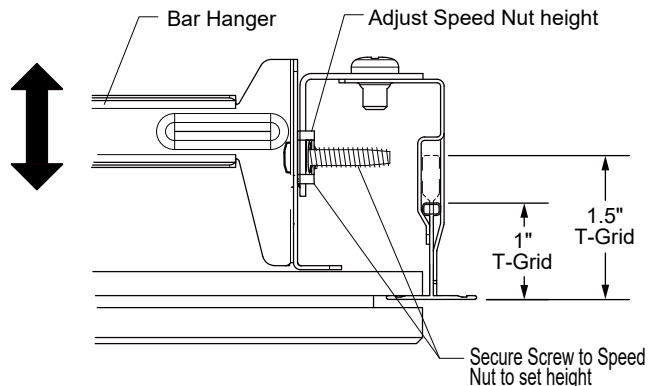

FIG 4.6 Adjust vertical Housing height

HOUSING INSTALLATION

BB - Butterfly Bracket - For Commercial C-Channel or T-GRID Mounting

STEP 1 Attach Butterfly Brackets to either ends or sides of mounting frame using existing screws - **FIG 5.2.**

STEP 2 Slide c-channel or bar through bracket and adjust height with thumb screw - **FIG 5.3.**

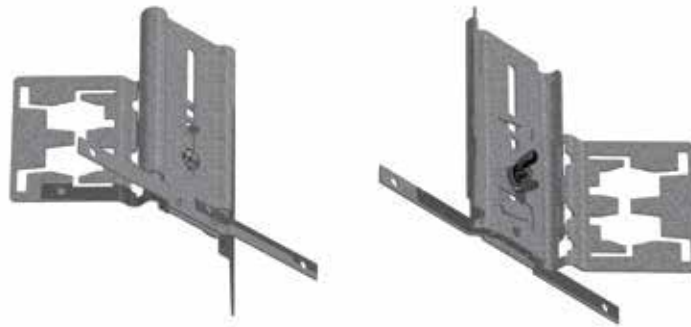

FIG 5.1 Butterfly Brackets (1 Set)

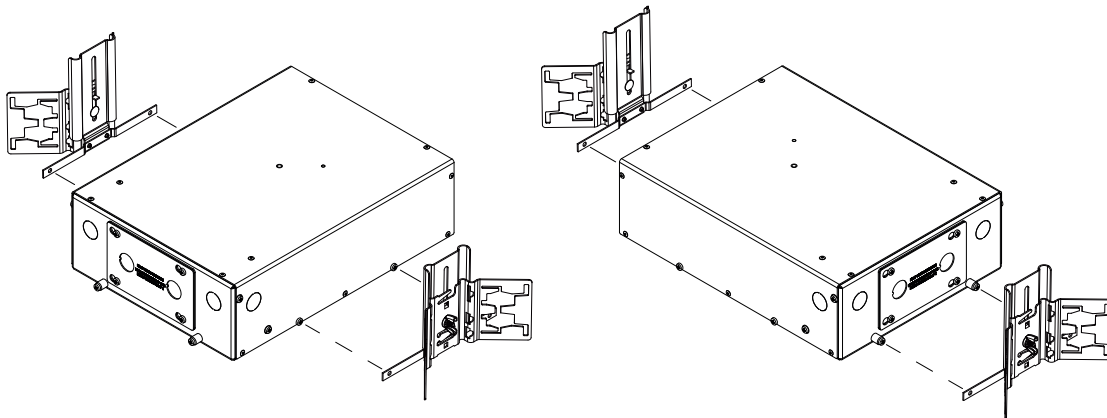

FIG 5.2 Butterfly Bracket/Housing Position

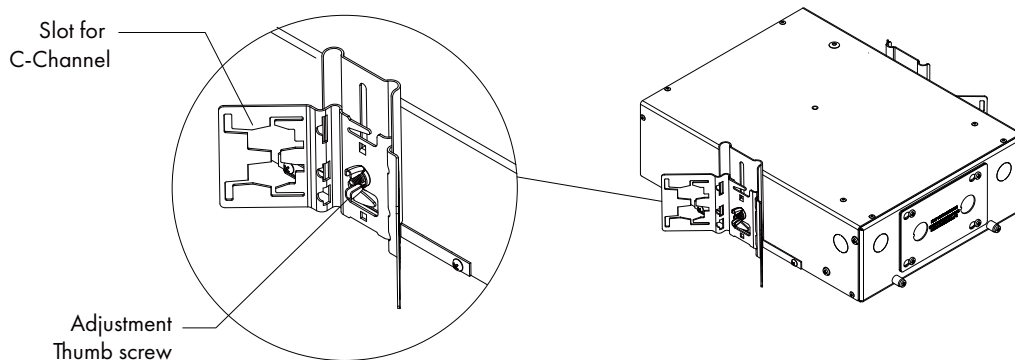

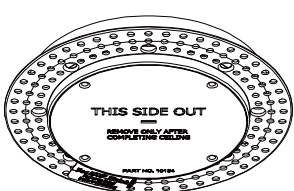
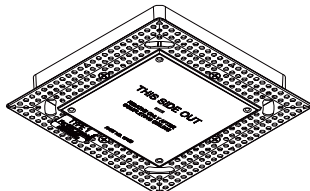
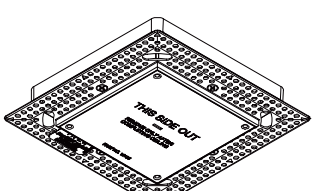
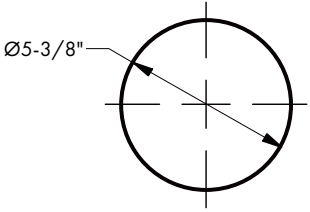
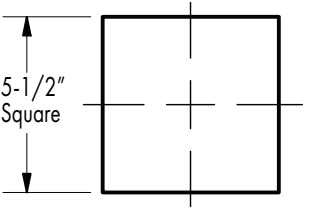

FIG 5.3 Butterfly Bracket Adjustment

CEILING CUTOUTS FOR PLASTER/SHEETROCK CEILINGS

Refer to 800 Series Trim Installation Instructions (92005) for additional details

		Round Trims		Square Trims	
Trim Model					
		FR-P-1	FR-P-2	FS-P-1	FS-P-2
		Round Trim Cutout		Square Trim Cutout	
			Tolerance: Round Trim Cutout $\pm 1/16$ "		Tolerance: Square Trim Cutout $+1/16$ "

LAMP MODULE J2S INSTALLATION / ADJUSTMENT / REMOVAL

CAUTION: ▶ Turn off power at wall switch & review all instructions on this page before proceeding.
▶ Always allow lamp module to cool before servicing.

Installation (not required if pre-installed into housing):

Step 1 Before installing Lamp Module, make sure correct LED Power Supply Module is installed & Lock Shaft is in unlocked position - **FIG 7.1**.

Step 2 Insert Lamp Module into housing as shown then adjust to 45° position to expose Fastener. Secure to Housing Center Stud - **FIG 7.2 & 7.3**.

Step 4 Plug Wire Connector from Lamp Module into Power Supply Module connector. Push wire up inside housing to avoid interference during adjustment - **FIG 7.2**.

Adjustment: Adjust desired horizontal position & vertical aiming angle as shown in **FIG 7.4**.

Removal: To remove lamp module follow steps above in reverse order.

Replacement: Contact Number Eight Lighting for replacement Lamp Module.

Optional Accessories: Unscrew Lamp Ring to add/ remove accessories - **FIG 7.2**.

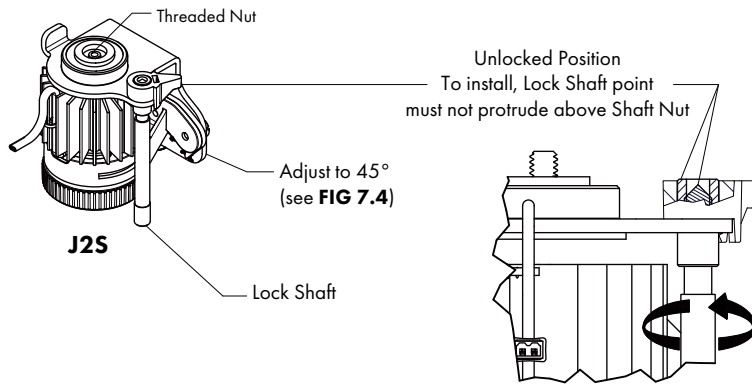

FIG 7.1 Preparing Lamp Module J2S for installation

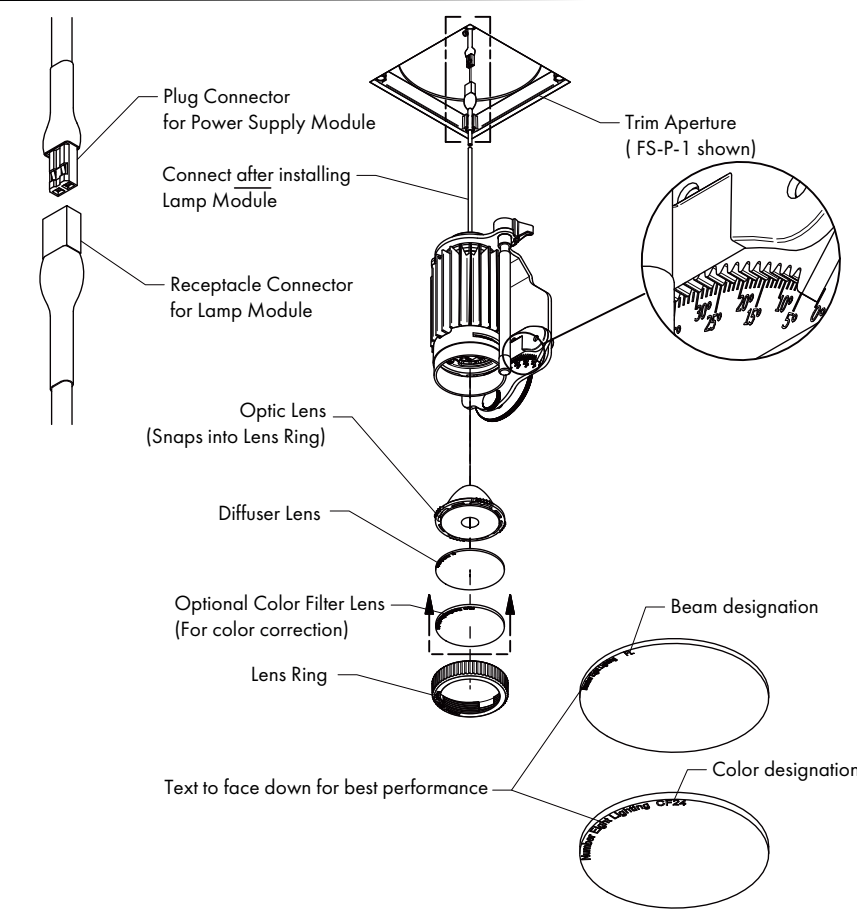
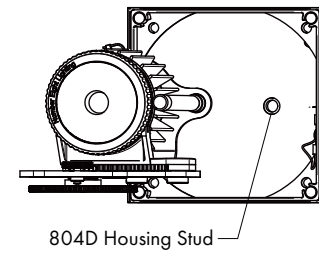
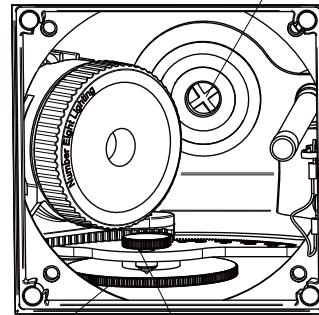

FIG 7.2 Installing Lamp Module J2S



Tighten Lamp Module Fastener to Housing Center Stud



To expose lamp module fastener, adjust vertical axis angle to 45 deg using Gear Knob (See FIG 7.4)

FIG 7.3 Securing Lamp Module to Housing

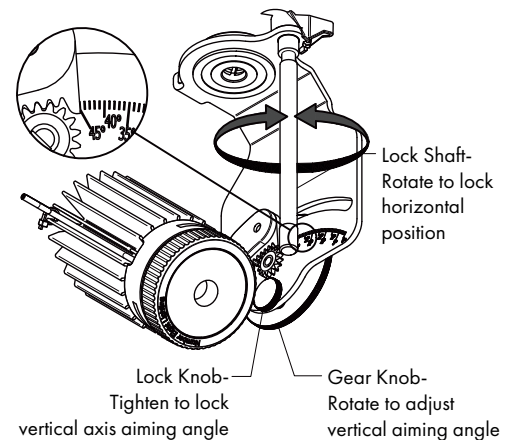

FIG 7.4 Aiming Adjustment

LAMP MODULE J2S-TW INSTALLATION/ADJUSTMENT/REMOVAL

CAUTION: ▶ Turn off power at wall switch & review all instructions on this page before proceeding.
▶ Always allow lamp module to cool before servicing.

Installation (not required if pre-installed into housing):

STEP 1 Before installing Lamp Module, make sure accessories & correct LED Power Supply Module are installed & Lock Shaft is in unlocked position - **FIG 8.1 & 8.2.**

STEP 2 Insert Lamp Module into housing as shown then adjust to 45° position to expose fastener. Secure to Housing Center Stud - **FIG 8.2 & 8.3.**

STEP 3 Plug Wire Connectors from Lamp Module into Power Supply Module connectors. Push wires up inside housing to avoid interference during adjustment - **FIG 8.2.**

Adjustment: Adjust desired horizontal position & vertical aiming angle as shown in **FIG 8.4.**

Removal: To remove lamp module follow steps above in reverse order.

Replacement: Contact Number Eight Lighting for replacement Lamp Module.

Optional Accessories: Unscrew Lamp Ring to add/ remove accessories - **FIG 8.2.**

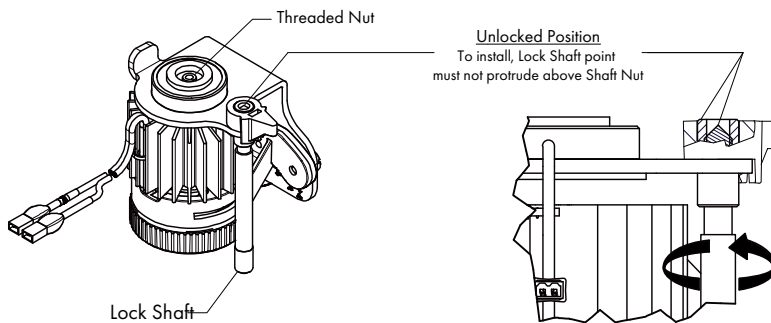
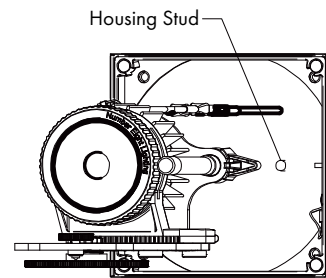
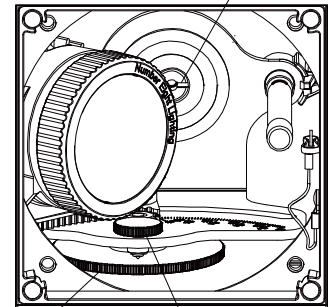

FIG 8.1 Preparing Lamp Module J2S -TW for installation



Tighten Lamp Module Fastener to Housing Stud



To expose lamp module fastener, adjust vertical axis angle to 45° using Gear Knob (See FIG 8.4)

FIG 8.3 Securing Lamp Module to Housing

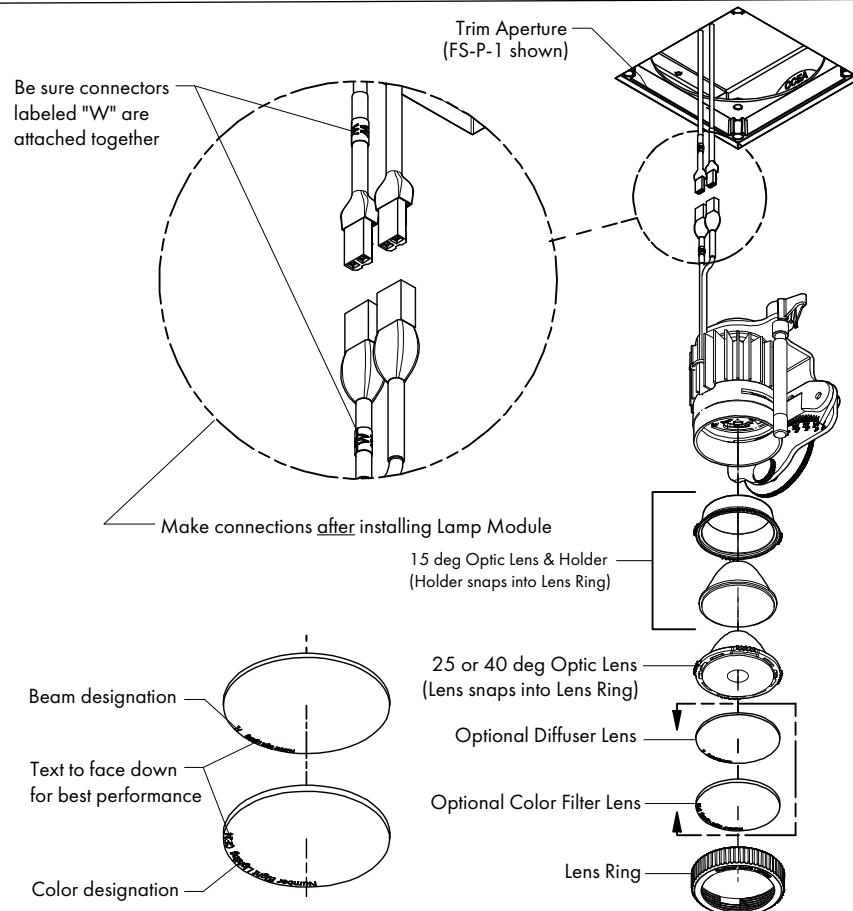

FIG 8.2 Installing Lamp Module J2S-TW

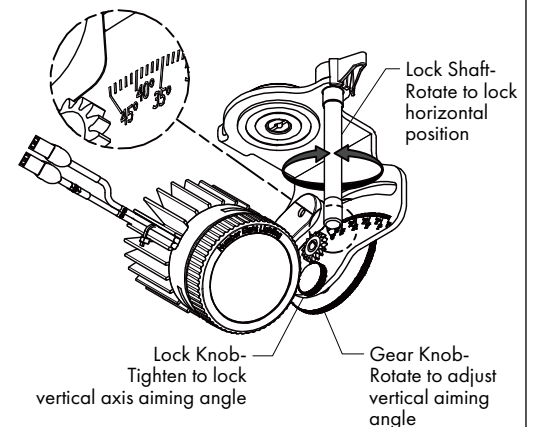

FIG 8.4 Aiming Adjustment

WW-8 WALL WASH TRIM PLATE - INSTALLATION INSTRUCTIONS

WW-8 Trim Plate Models for 800 Series Housings

Important: WW-8 Trim Plates can only be used with J2S Lamp Modules. For optimal performance use 40° TIR Optic with HI, HI-3, WD, WD-2, WD-4 or TW LED.

Use 10° optic and FL lens with HI-2 LED.

STEP 1 Unlock & adjust J2S Lamp Module to 20° vertical aiming angle for optimal wall wash performance - **FIG 9.1**.

STEP 2 Unlock & adjust horizontal position to aim light towards wall surface to be illuminated - **FIG 9.2**.

STEP 3 Orient & install Wall Wash Trim Plate into Trim as shown - **FIG 9.3**.

Note: Magnets will permit Trim Plates to only be installed in 4 horizontal orientations.

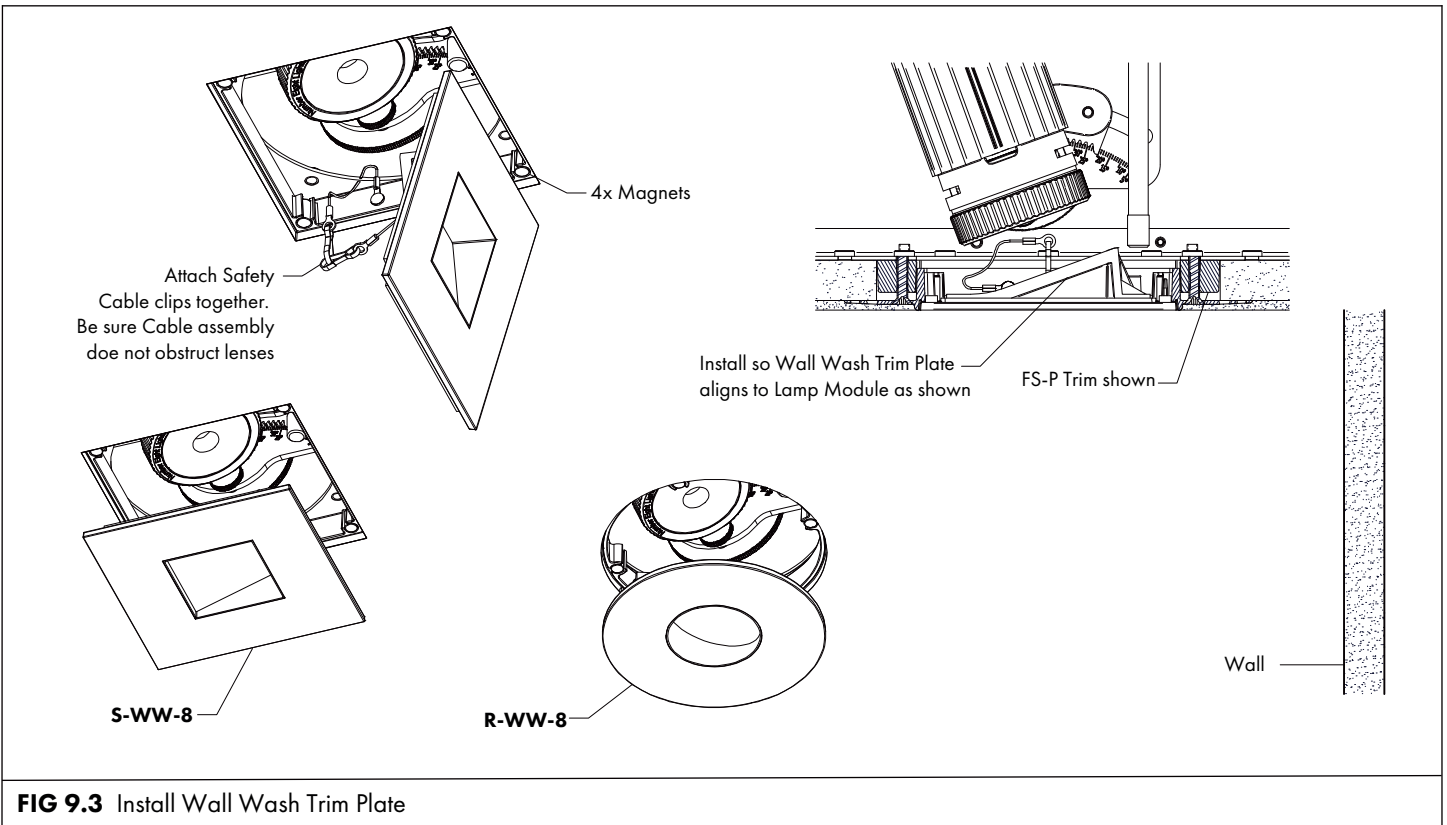
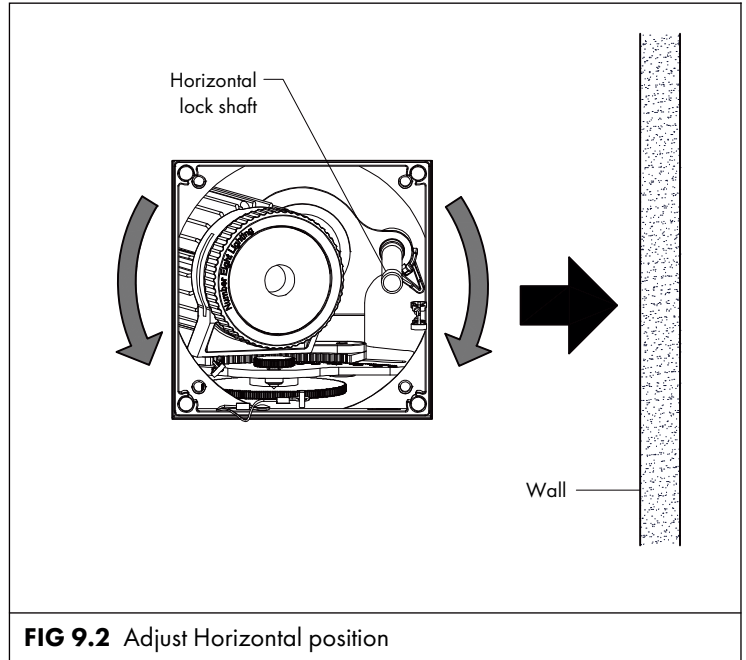
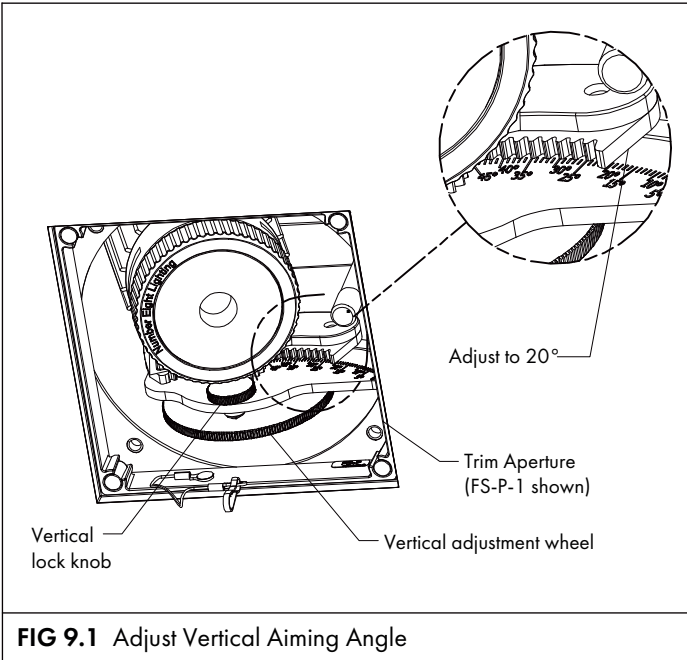

LAMP MODULE K2S INSTALLATION/ADJUSTMENT/REMOVAL

CAUTION: ▶ Turn off power at wall switch & review all instructions on this page before proceeding.
▶ Always allow lamp module to cool before servicing.

Installation (not required if pre-installed into housing):

STEP 1 Before installing Lamp Module, make sure the LED Power Supply Module is installed (shown on page 12)..

STEP 2 Pull Power Module Connector through opening & insert Lamp Module into housing as shown. Secure Lamp Module to Housing Nut or Stud & hand tighten - **FIG 10.1 & 02.2**.

STEP 3 Plug Wire Connector from Lamp Module into Power Supply Module connector. Push wire up inside housing to avoid interference with LED - **FIG 10.2**.

Removal: To remove lamp module follow steps above in reverse order.

Replacement: Contact Number Eight Lighting for replacement Lamp Module.

Optional Accessories: Unscrew Lamp Ring to add/remove accessories- **FIG 10.1**.

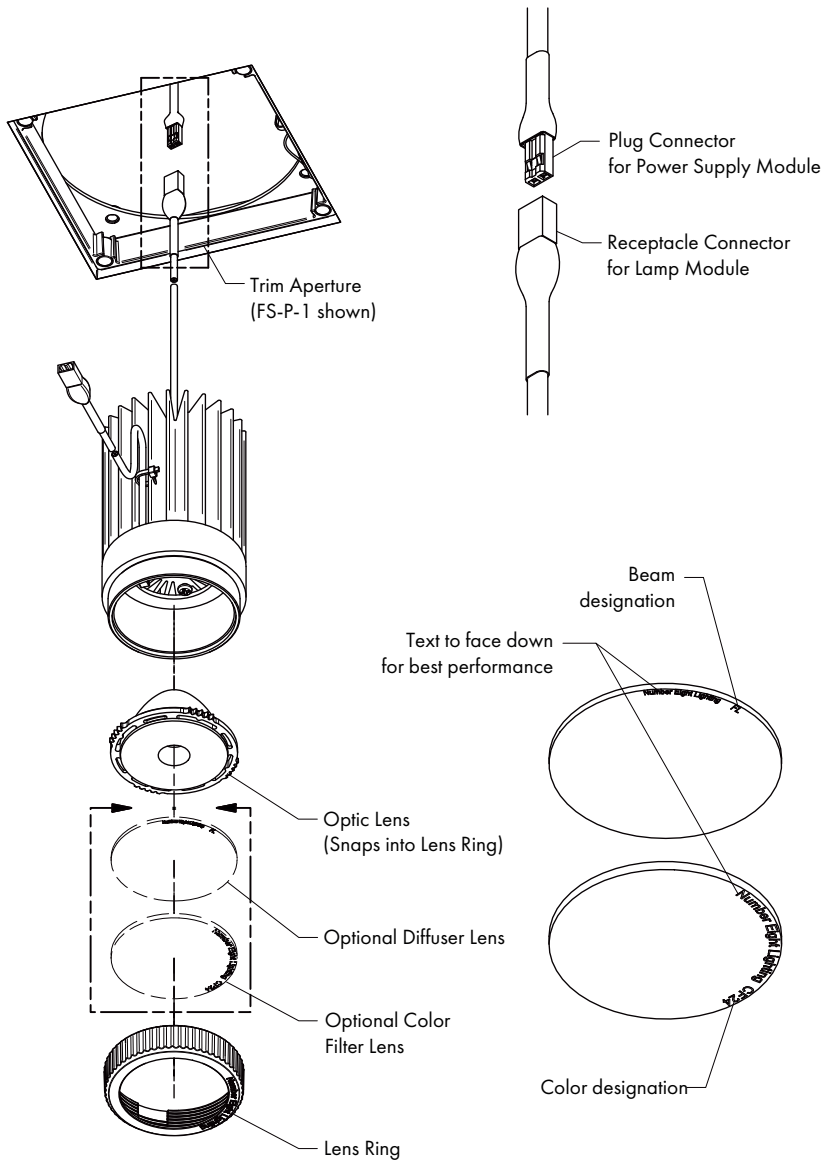
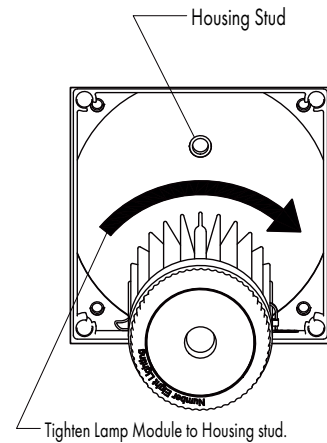
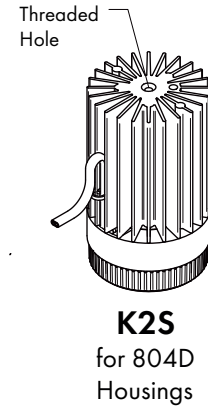

FIG 10.1 Installing Lamp Module K2S & Accessories



Note: If LED fails to light, check if connectors are plugged together as shown.

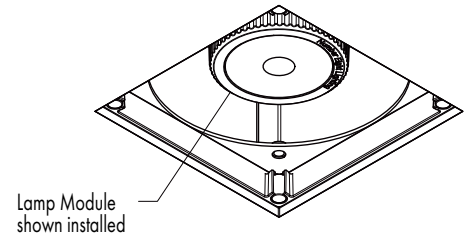

FIG 10.2 Securing Lamp Module to Housing

LAMP MODULE M2S INSTALLATION / ADJUSTMENT / REMOVAL

CAUTION: ▶ Turn off power at wall switch & review all instructions on this page before proceeding.
▶ Always allow lamp module to cool before servicing.

Installation:

STEP 1 Before installing Lamp Module M2S, make sure LED Power Supply Module is installed (shown on Page 12).

Note: For use of M2S with Sloped Ceilings Only-See recommended Housing installation orientation - **FIG 11.1**.

STEP 2 Adjust vertical to 90° position as shown in **FIG 11.3**. Note: angle adjustment is limited on ceilings over 5/8" thick & when Mirror Reflector is aligned facing narrow sides of Housing.

STEP 3 Plug Wire Connector from Lamp Module into Power Supply Module Connector. Push wire up inside Housing to avoid interference during installation - **FIG 11.4**.

STEP 4 Choose general aiming position desired. Attach Safety Cable from Trim Cable Clip to Lamp Module before inserting Lamp Module into Housing aperture. Seat Trim Plate into Trim.

Note: Horizontal & vertical aiming position adjustment is lockable using Lock Knobs. General aiming position is easily changed by pulling Lamp Module out slightly & rotating into one of 4 positions - **FIG 11.2 & 11.3**.

Removal: To remove Lamp Module follow steps above in reverse order.

Replacement: Contact Number Eight Lighting for replacement LED Engine Subassy. Remove Lamp Module & unscrew LED Engine Subassy for replacement.

Optional Accessories: Unscrew LED Engine Subassy to add/remove Lens accessories - **FIG 11.2**.

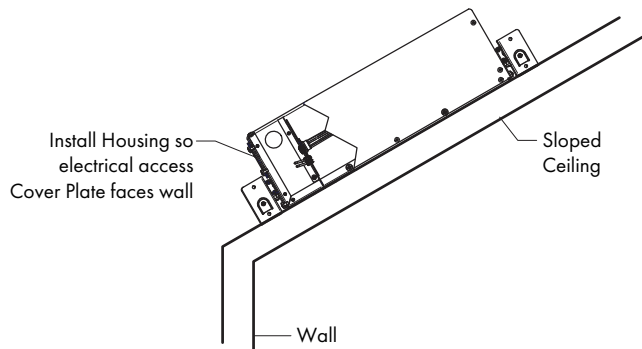

FIG 11.1 Recommended Housing Orientation for Sloped Ceiling

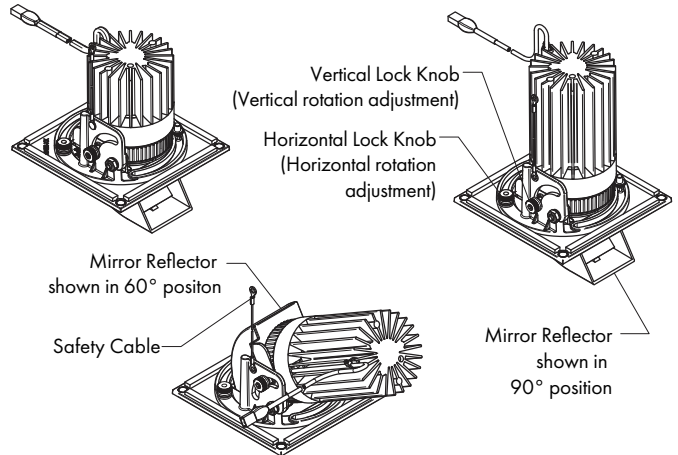

FIG 11.3 Lamp Module Adjustment

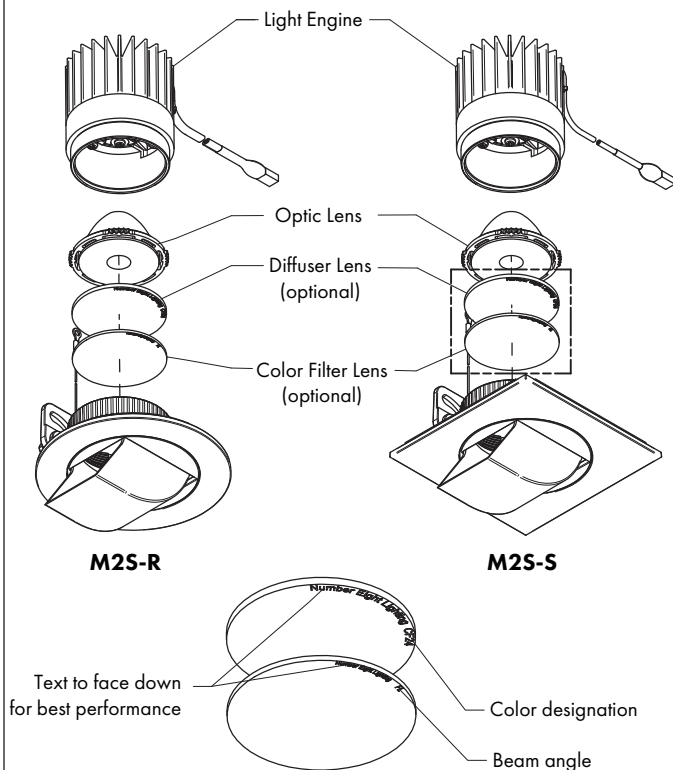

FIG 11.2 Installing Lamp Module Accessories

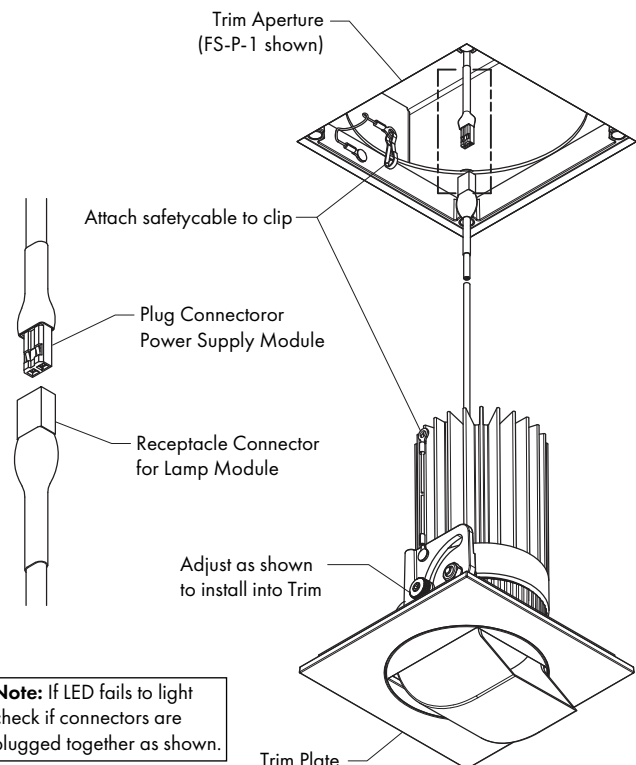

FIG 11.4 Securing Lamp Module to Housing & Trim

LED POWER SUPPLY MODULE REMOVAL / REPLACEMENT

CAUTION: ▶ Turn off power at wall switch & review all instructions on this page before proceeding.
▶ Always allow lamp module to cool before servicing.

To remove LED Power Supply Modules

Step 1 To access Power Supply Module the Lamp Module must first be removed (For Lamp Modules refer to **Pages 7-11**).

Step 2 Unscrew & remove Thumb Knob inside Housing as shown. Tilt Power Supply Module to disengage offset tab from housing as shown - **FIG 12.1**.

Step 3 Pull Power Supply Module away from threaded stud and pull wires & Power Connectors out of the Junction Box - **FIG 12.2**.

Step 4 Disconnect Power Supply Connectors. For models with 0-10 drivers, also disconnect purple & gray wires - **FIG 12.2**.

Step 5 Pull Power Supply Module through aperture - **FIG 12.3**.

For Replacement: Replace all parts in steps above in reverse order. Push all wires into wiring compartment & replace Power Supply Module as shown in **FIG 12.4**.

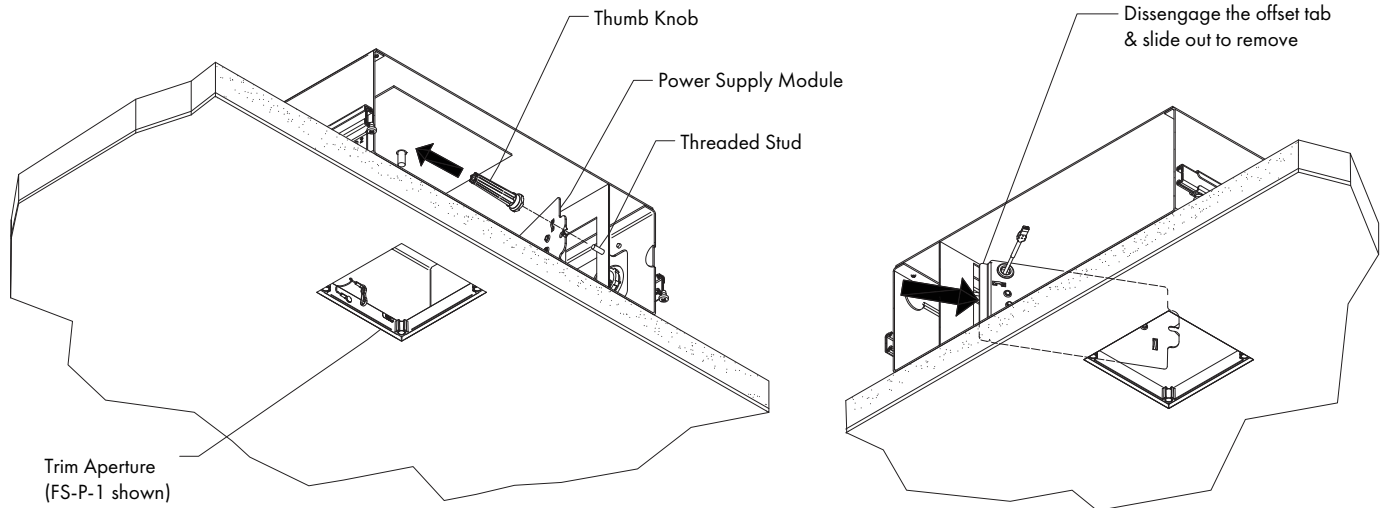

FIG 12.1 Remove Thumb Knob & Disengage Power Supply Module (Model 804 shown)

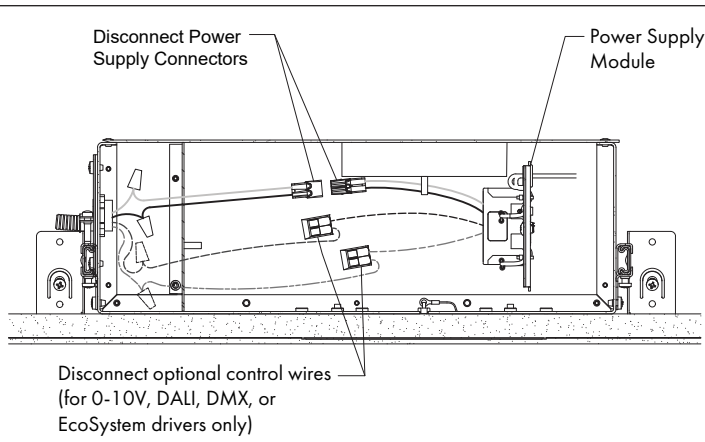

FIG 12.2 Remove Power Supply Module & disconnect wires

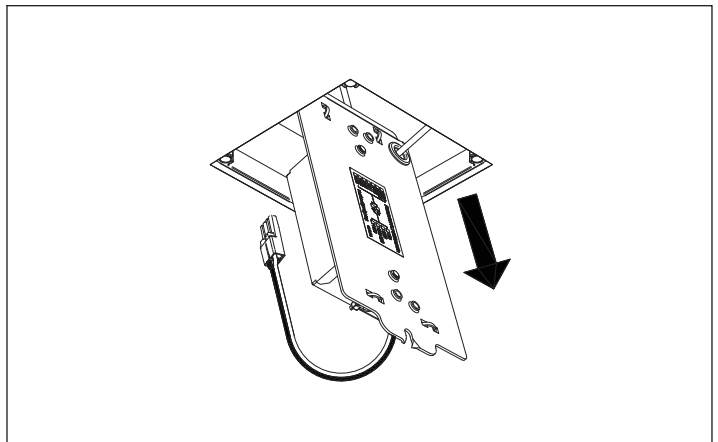

FIG 12.3 Pass Power Supply Module Through Aperture

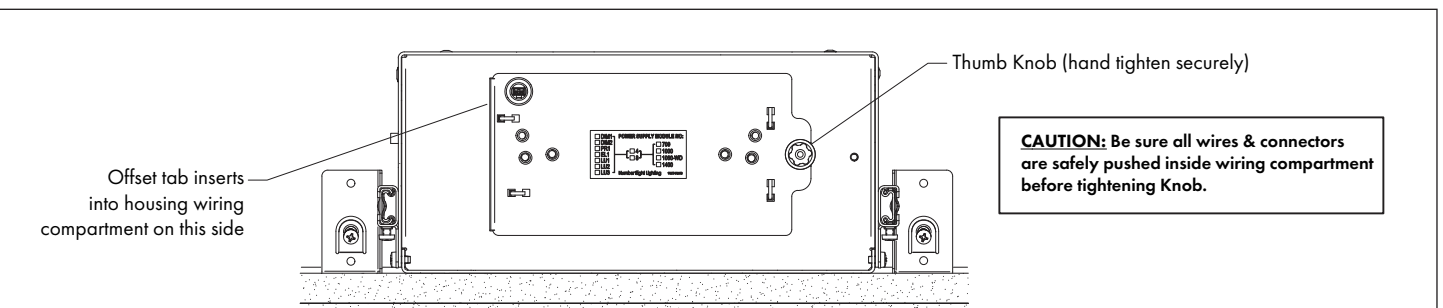

FIG 12.4 Replace Power Supply Module & Secure With Thumb Knob

SINGLE LAMP WIRING INSTRUCTIONS

For PR1 / EL1 / EL1-01 / EL2 / EL2-01 / LU2 / LU4 Dimming Options

CAUTION: TO AVOID RISK OF FIRE OR ELECTRIC SHOCK

Turn off power at circuit breaker or fuse panel & read instructions completely before proceeding. Failure to follow instructions may void warranty. Save these instructions.

- Installation must be by a qualified electrician only and must conform to National Electric code and local regulations.
- Verify correct dimming system, lamp module, power supply type, and input supply requirements.
- Always allow LED assembly to cool before servicing.
- Do not install where insulation or ambient temperatures will exceed maximum values noted in product specifications. See www.8lighting.com for current product specifications.
- For multi-lamp refer to lighting plan to determine lamp circuit control configuration.

PR1 - PHASE CONTROL

STEP 1 Loosen screws to remove cover plate. Verify correct dimming system, power supply type and input supply requirements-**FIG 13.2**.

STEP 2 Remove required knockouts in cover plate or housing & secure suitable electrical connectors into knock outs for supply wires – **FIG 13.2**

STEP 3 Make wire connections shown below & push all wires & connections completely inside wiring compartment – **FIG 13.1 & 13.2**.

STEP 4 Replace & secure box cover plate using screws provided – **FIG 13.2**.

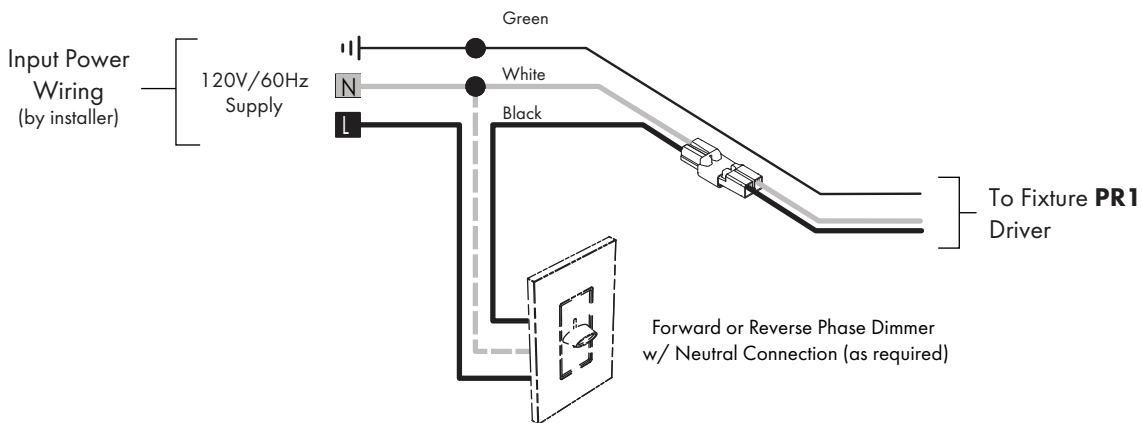

Phase Control Notes:

PR1 drivers are Forward or Reverse Phase dimmable.

For compatible dimmers for use with PR1 drivers see: www.8lighting.com/resources-downloads

FIG 13.1 Wiring Diagram

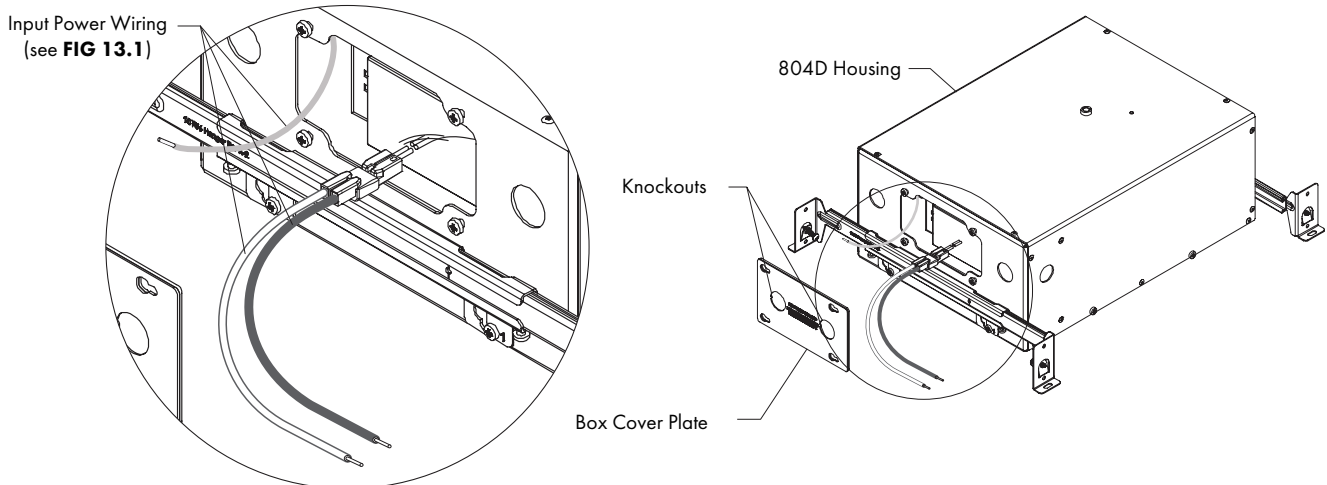

NOTE: For compatible dimmers for use with PR1 drivers see www.8lighting.com/resources-downloads/

FIG 13.2 Wire Connections

SINGLE LAMP WIRING INSTRUCTIONS

EL1/EL1-01 - 0-10V CONTROL

- STEP 1** Loosen screws to remove cover plate. Verify correct dimming system, power supply type and input supply requirements-**FIG 14.2**.
STEP 2 Remove required knockouts in cover plate or housing & secure suitable electrical connectors into knock outs for supply wires – **FIG 14.2**
STEP 3 Make wire connections shown below & push all wires & connections completely inside wiring compartment – **FIG 14.1 & 14.2**.
STEP 4 Replace & secure box cover plate using screws provided – **FIG 14.2**.

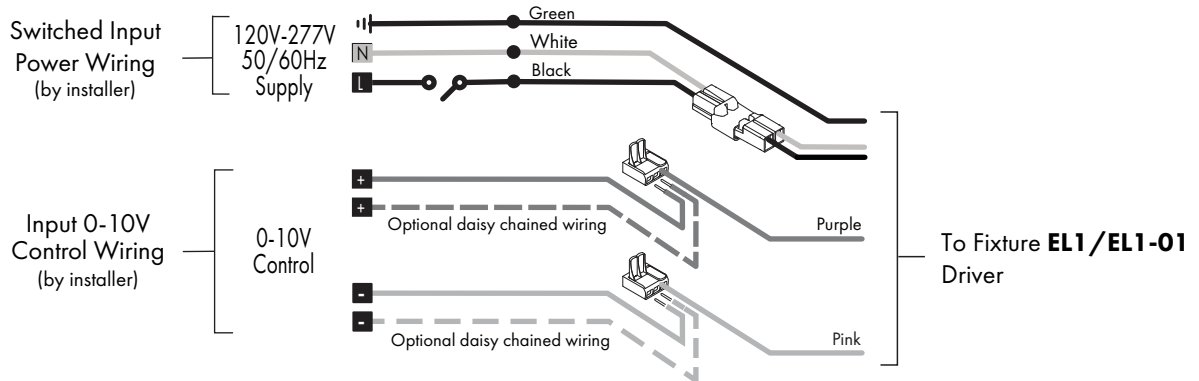

0-10V Control Notes:

0-10V control wiring is polarity sensitive and should be run as Class 2.
 300' is the maximum control wiring run length to reduce EMI susceptibility and voltage drop. Voltage drop should be no greater than 0.3V.
 For compatible dimmers for use with **EL1/EL1-01** drivers see: www.8lighting.com/resources-downloads.

FIG 14.1 Wiring Diagram

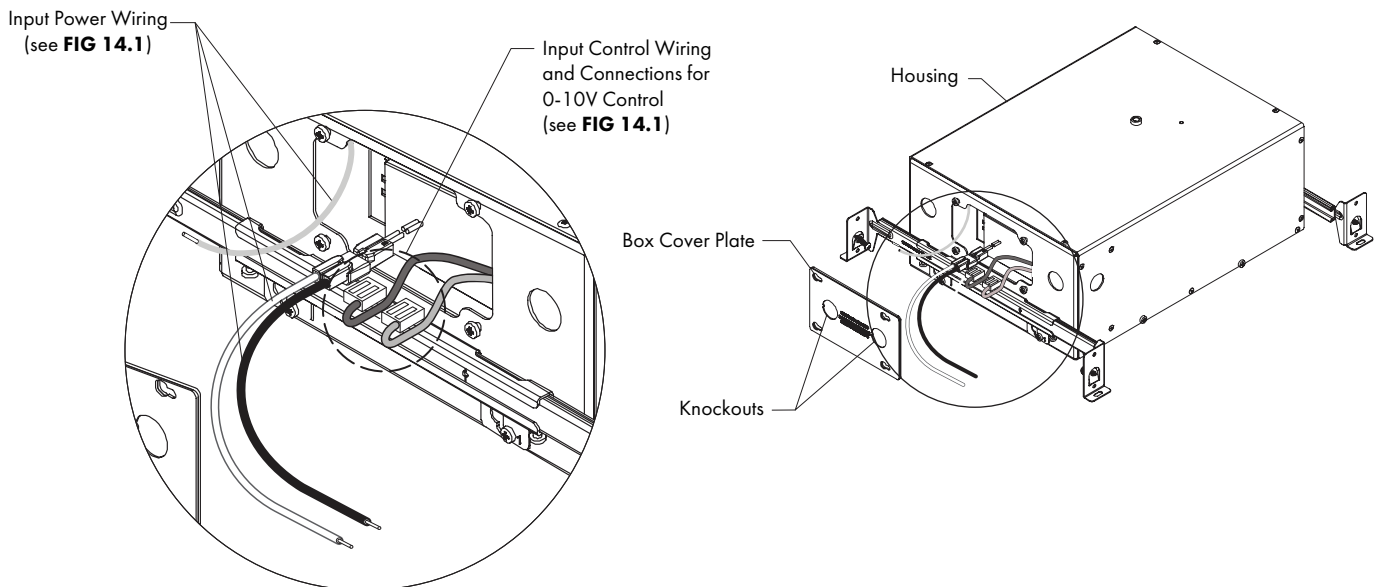

NOTE: For compatible dimmers for use with **EL1/EL1-01** drivers see www.8lighting.com/resources-downloads/

FIG 14.2 Wire Connections

SINGLE LAMP WIRING INSTRUCTIONS

EL2/EL2-01 - DALI CONTROL

- STEP 1** Loosen screws to remove cover plate. Verify correct dimming system, power supply type and input supply requirements-**FIG 15.2**.
STEP 2 Remove required knockouts in cover plate or housing & secure suitable electrical connectors into knock outs for supply wires – **FIG 15.2**.
STEP 3 Make wire connections shown below & push all wires & connections completely inside wiring compartment – **FIG 15.1** & **15.2**.
STEP 4 Replace & secure box cover plate using screws provided – **FIG 15.2**.

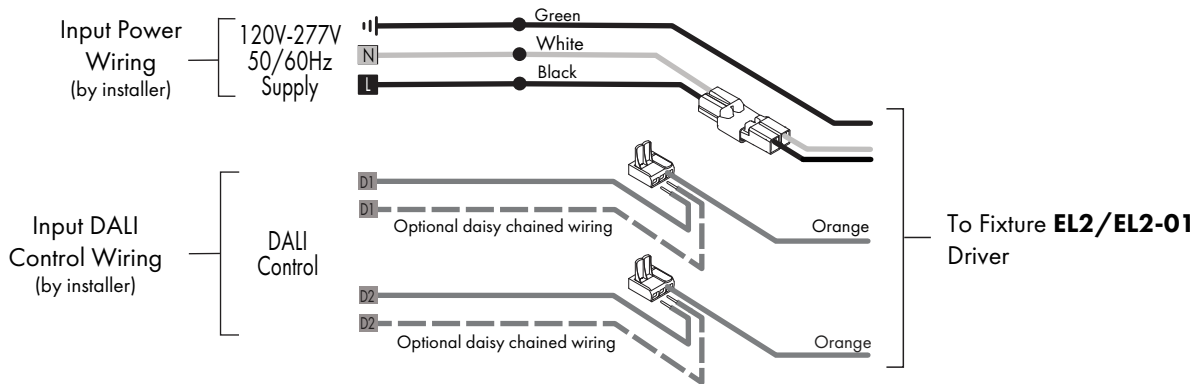

DALI Control Notes:

DALI control wiring is not polarity sensitive and can be run as Class 1 or 2.
 Up to 64 **EL2/EL2-01** power supplies can be daisy chained per DALI control loop. Maximum control wiring run length is 1000'.
 For compatible dimmers for use with EL2/EL2-01 drivers see: www.8lighting.com/resources-downloads/.

FIG 15.1 Wiring Diagram

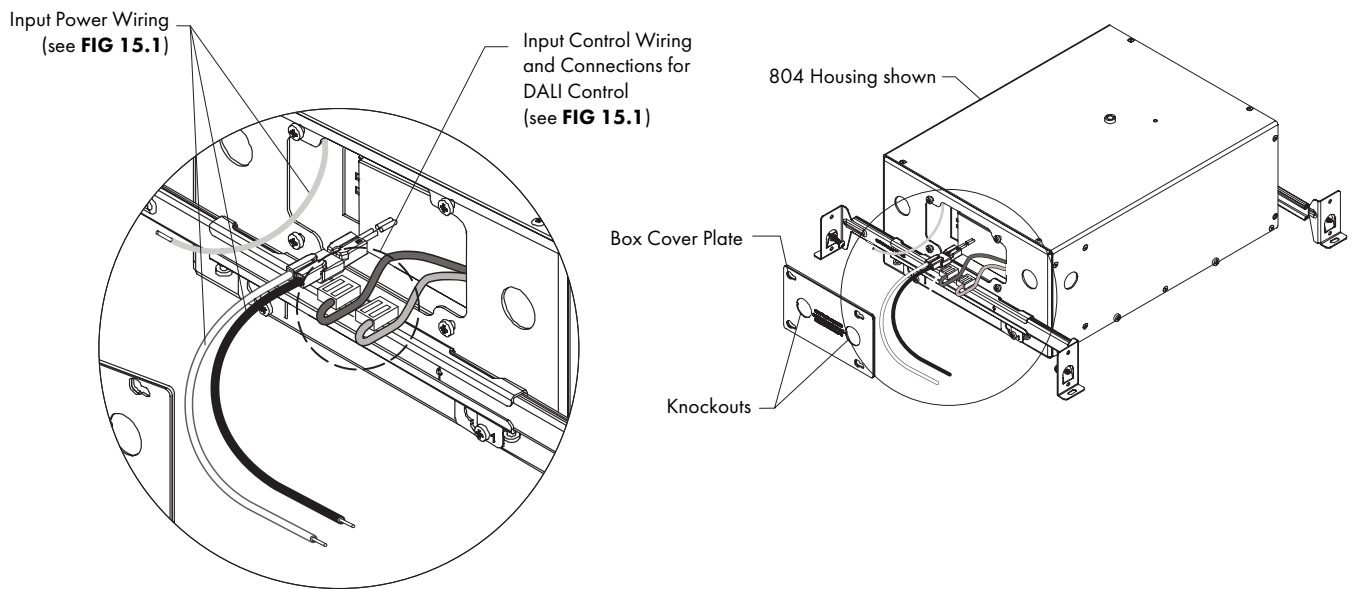

NOTE: For compatible dimmers for use with **EL2/EL2-01** drivers see www.8lighting.com/resources-downloads/

FIG 15.2 Wire Connections

SINGLE LAMP WIRING INSTRUCTIONS

LU2 / LU4 - LUTRON ECOSYSTEM CONTROL

- STEP 1** Loosen screws to remove cover plate. Verify correct dimming system, power supply type and input supply requirements-**FIG 16.2**.
STEP 2 Remove required knockouts in cover plate or housing & secure suitable electrical connectors into knock outs for supply wires – **FIG 16.2**.
STEP 3 Make wire connections shown below & push all wires & connections completely inside wiring compartment – **FIG 16.1** & **16.2**.
STEP 4 Replace & secure box cover plate using screws provided – **FIG 16.2**.

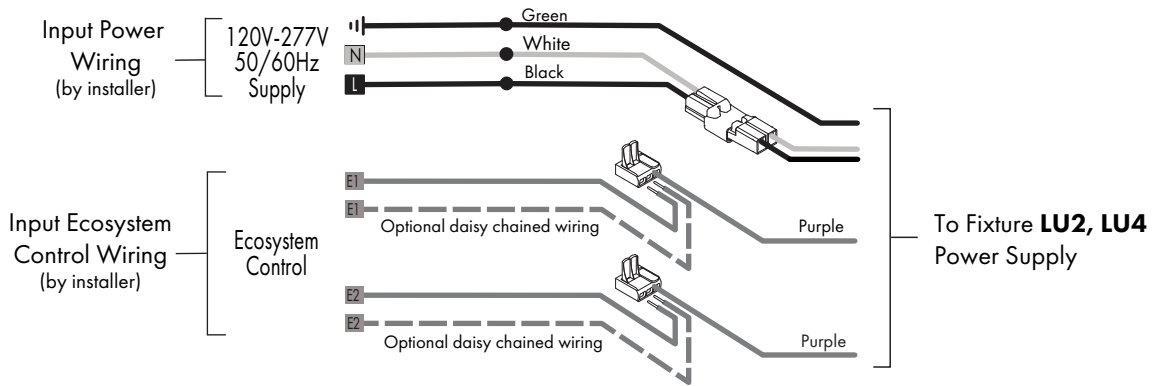

Lutron Ecosystem Control Notes:

Up to 64 LU2 / LU4 power supplies can be daisy chained per Ecosystem control loop.
 Maximum control wiring run length is 1000'.
 For additional information, contact LED Center of Excellence at 1.877.346.5338 or LEDs@lutron.com

FIG 16.1 Wiring Diagram

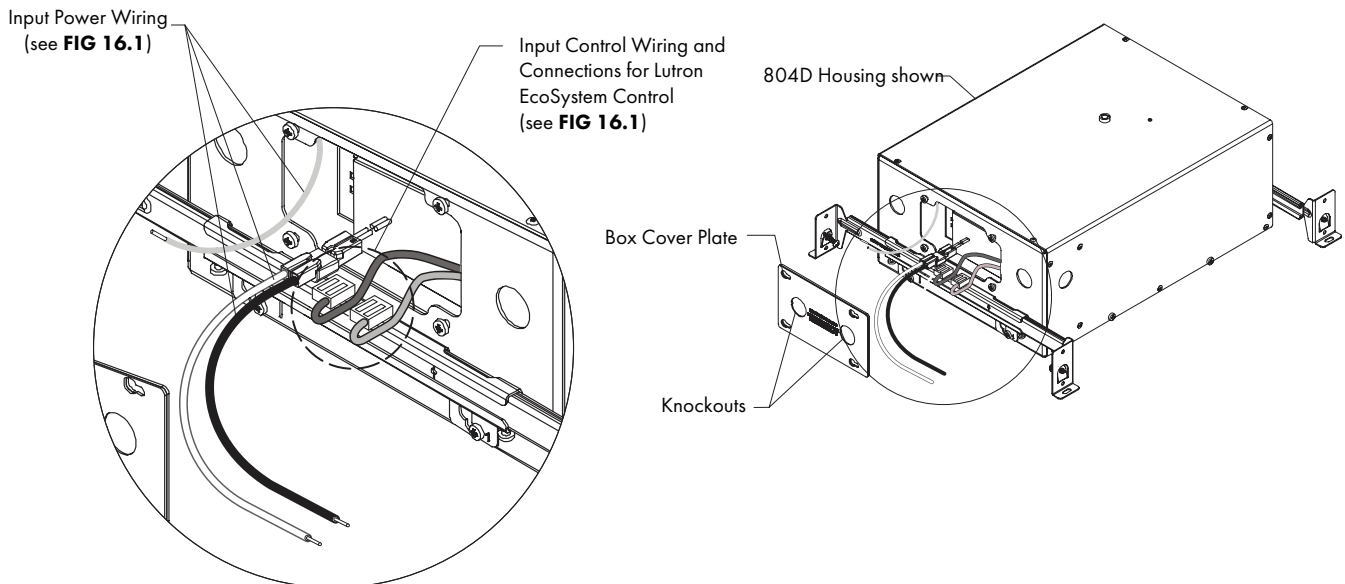
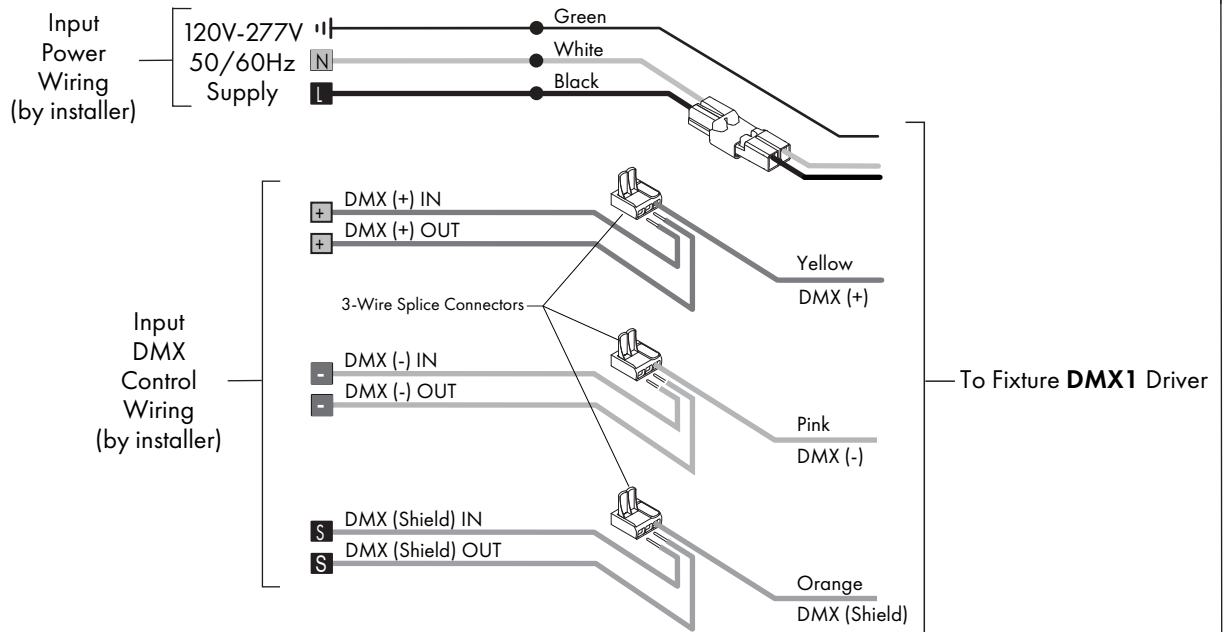

FIG 16.2 Wire Connections

SINGLE LAMP WIRING INSTRUCTIONS

DMX1 - DMX CONTROL

- STEP 1** Loosen screws to remove cover plate & connect driver output wires using electrical connectors at wiring compartment – **FIG 17.2**.
STEP 2 Remove required knockouts in cover plate or housing & secure suitable electrical connectors into knock outs for supply wires – **FIG 17.2**.
STEP 3 Make wire connections & push all wires & connections completely inside wiring compartment – **FIG 17.1 & 17.2**.
STEP 4 Replace & secure box cover plate using screws provided – **FIG 17.2**



DMX Notes:

DMX control wiring is polarity sensitive and should be run as Class 2. Each **DMX1** driver is one “unit load”. DMX runs without a repeater/signal booster should be limited to no more than 32 drivers including controller depending on the site conditions. **DMX1** drivers are RDM compatible and addressable by others in the field. Termination of the DMX runs is to be done by others per DMX512A specification. Maximum control wiring run length is 1000'. For compatible dimmers for use with **DMX1** drivers see: www.8lighting.com/resources-downloads.

FIG 17.1 Wiring Diagram

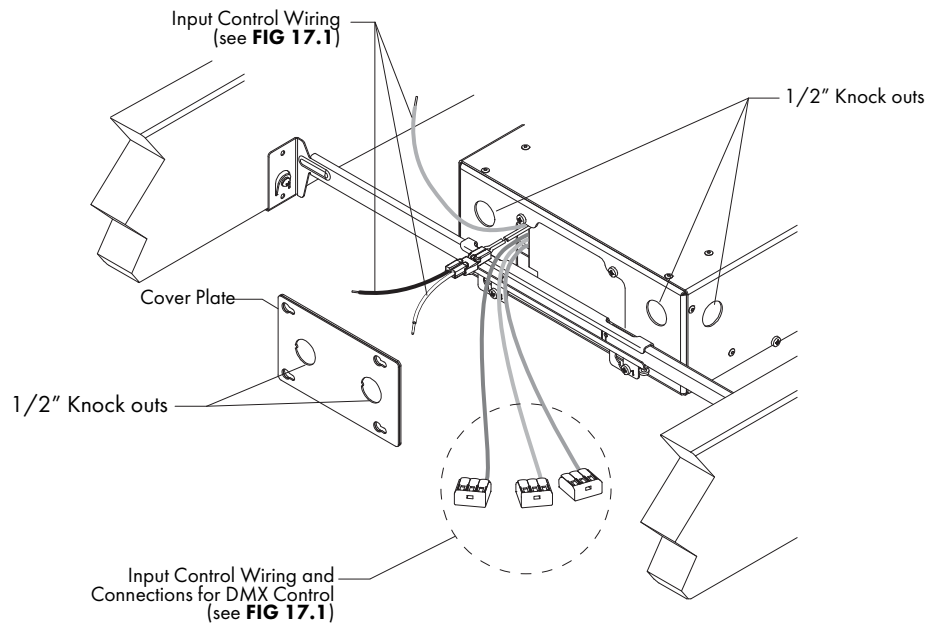

NOTE: For compatible dimmers for use with **DMX1** drivers see www.8lighting.com/resources-downloads/

FIG 17.2 Wire Connections

SINGLE LAMP WIRING INSTRUCTIONS- 2 CHANNEL TUNABLE WHITE

For **EL3 / EL5 / DMX2** - 2-Channel Dimming Options

CAUTION: TO AVOID RISK OF FIRE OR ELECTRIC SHOCK

Turn off power at circuit breaker or fuse panel & read instructions completely before proceeding.

Failure to follow instructions may void warranty. Save these instructions.

- Installation must be by a qualified electrician only and must conform to National Electric code and local regulations.
 - Verify correct dimming system, lamp module, power supply type, and input supply requirements.
 - Always allow LED assembly to cool before servicing.
 - Do not install where insulation or ambient temperatures will exceed maximum values noted in product specifications.
- See www.8lighting.com for current product specifications.

EL3 - 2 Channel DALI CONTROL

STEP 1 Loosen screws to remove cover plate. Verify correct dimming system, power supply type and input supply requirements-**FIG 18.2**.

STEP 2 Remove required knockouts in cover plate or housing & secure suitable electrical connectors into knock outs for supply wires – **FIG 18.2**.

STEP 3 Make wire connections shown below & push all wires & connections completely inside wiring compartment – **FIG 18.1 & 18.2**.

STEP 4 Replace & secure box cover plate using screws provided – **FIG 18.2**.

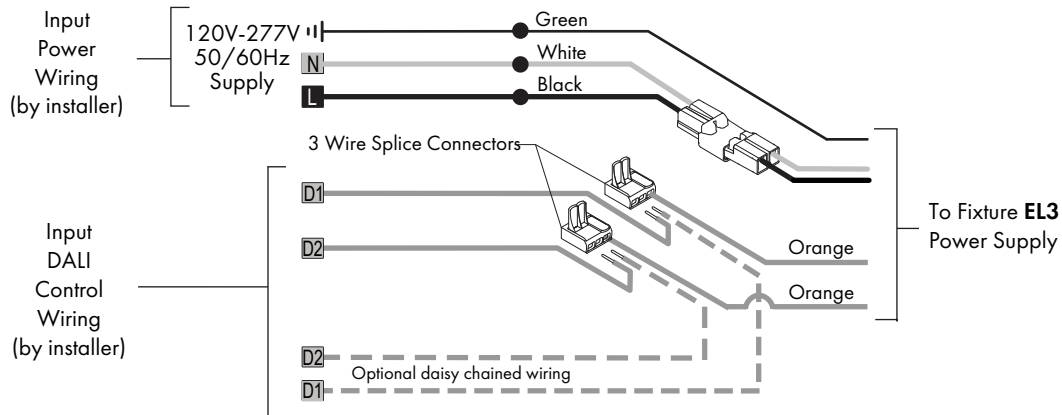

DALI Control Notes:

DALI control wiring is not polarity sensitive and can be run as Class 1 or 2. Each **EL3** driver will be discovered with two incremented short addresses: one for CCT and one for INTENSITY. Up to 32 **EL3** drivers can be daisy-chained per DALI control loop. Maximum control wiring run length is 1000'. For compatible dimmers for use with **EL3** drivers see: www.8lighting.com/resources-downloads.

FIG 18.1 Wiring Diagram

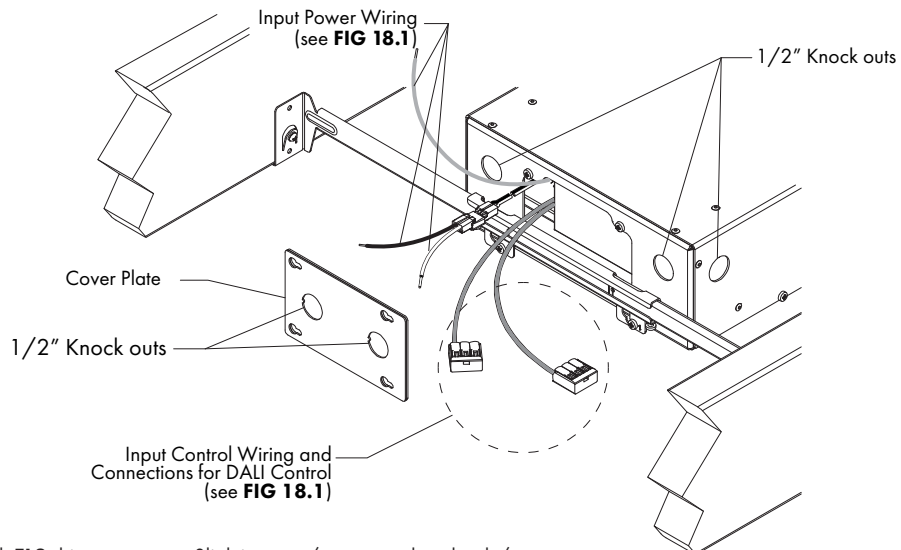

NOTE: For compatible dimmers for use with **EL3** drivers see www.8lighting.com/resources-downloads/

FIG 18.2 Wire Connections

SINGLE LAMP WIRING INSTRUCTIONS - 2 CHANNEL TUNABLE WHITE

EL5 2-CHANNEL 0-10V CONTROL

- STEP 1** Loosen screws to remove cover plate. Verify correct dimming system, power supply type and input supply requirements-**FIG 19.2**.
STEP 2 Remove required knockouts in cover plate or housing & secure suitable electrical connectors into knock outs for supply wires – **FIG 19.2**.
STEP 3 Make wire connections shown below & push all wires & connections completely inside wiring compartment – **FIG 19.1 & 19.2**.
STEP 4 Replace & secure box cover plate using screws provided – **FIG 19.2**.

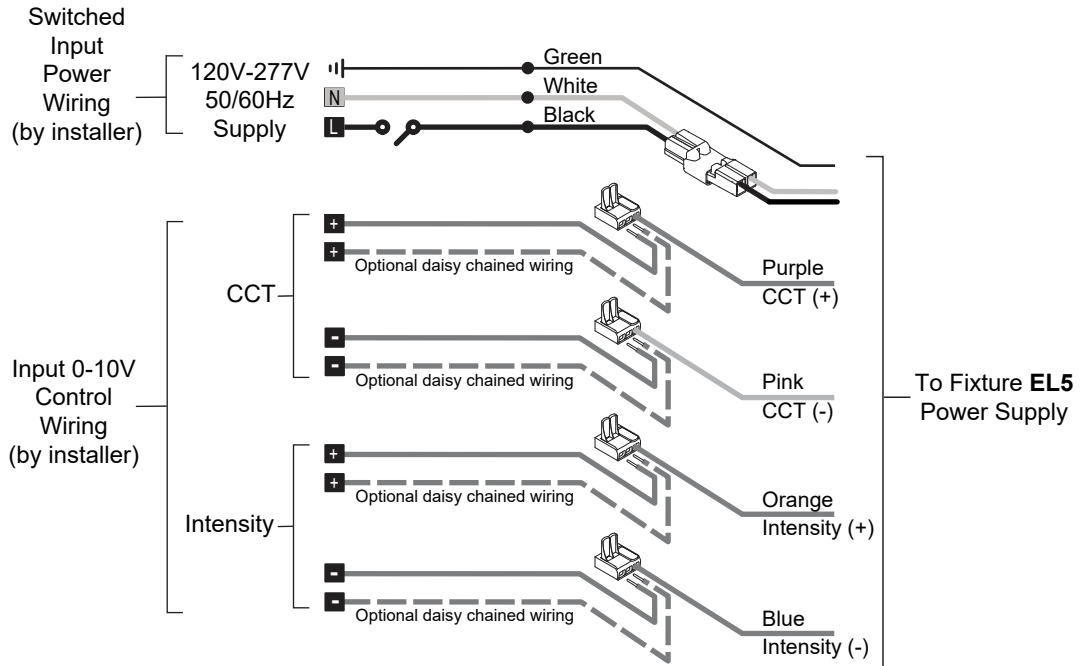

0-10V Control Notes:

0-10V control wiring is polarity sensitive and should be run as Class 2. Each **EL5** driver requires two pairs of Class 2 control wires: one pair for CCT and one pair for INTENSITY. 300' is the maximum control wiring run length to reduce EMI susceptibility and voltage drop. Voltage drop should be no greater than 0.3V. For compatible dimmers for use with **EL5** drivers see: www.8lighting.com/resources-downloads.

FIG 19.1 Wiring Diagram

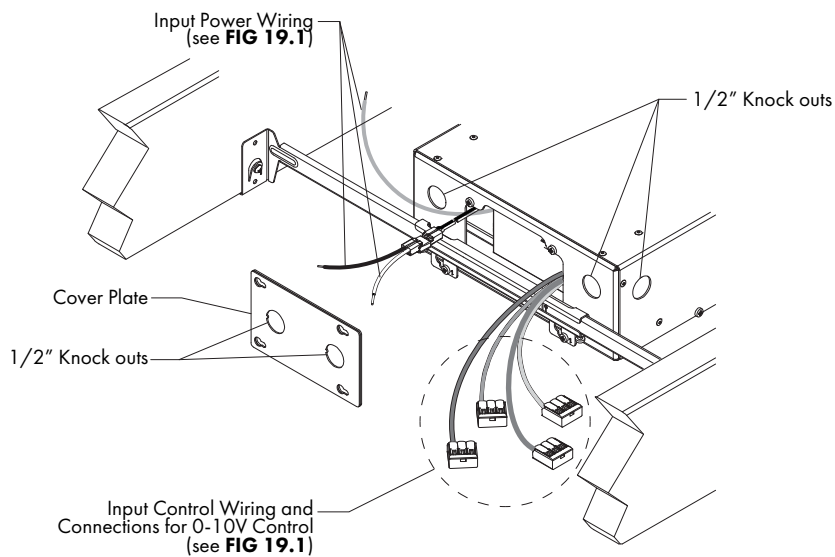

NOTE: For compatible dimmers for use with **EL5** drivers see www.8lighting.com/resources-downloads/

FIG 19.2 Wire Connections

SINGLE LAMP WIRING INSTRUCTIONS - 2 CHANNEL TUNABLE WHITE

DMX2 - 2 CHANNEL DMX CONTROL

- STEP 1** Loosen screws to remove cover plate & connect driver output wires using electrical connectors at wiring compartment – **FIG 20.2.**
STEP 2 Remove required knockouts in cover plate or housing & secure suitable electrical connectors into knock outs for supply wires – **FIG 20.2.**
STEP 3 Make wire connections & push all wires & connections completely inside wiring compartment – **FIG 20.1 & 20.2.**
STEP 4 Replace & secure box cover plate using screws provided – **FIG 20.2**

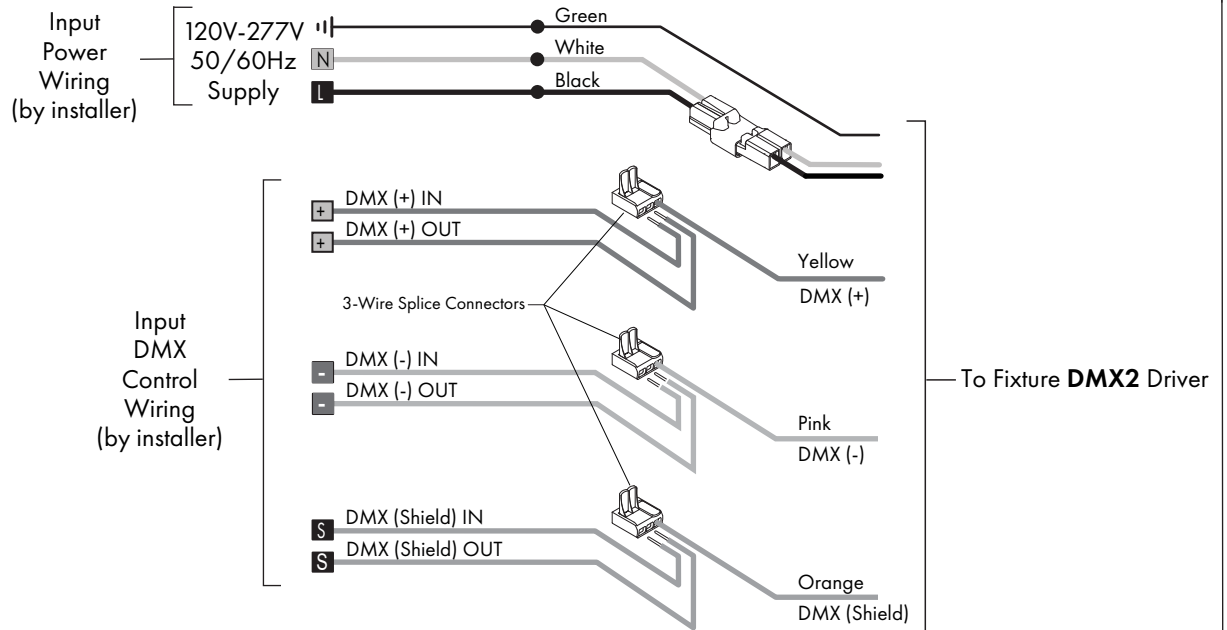

DMX Notes:

DMX control wiring is polarity sensitive and should be run as Class 2. Each **DMX2** driver is one "unit load". DMX runs without a repeater/signal booster should be limited to no more than 32 drivers including controller depending on the site conditions. **DMX2** drivers are RDM compatible and addressable by others in the field. Termination of the DMX runs is to be done by others per DMX512A specification. Maximum control wiring run length is 1000'.

For compatible dimmers for use with **DMX2** drivers see: www.8lighting.com/resources-downloads.

FIG 20.1 Wiring Diagram

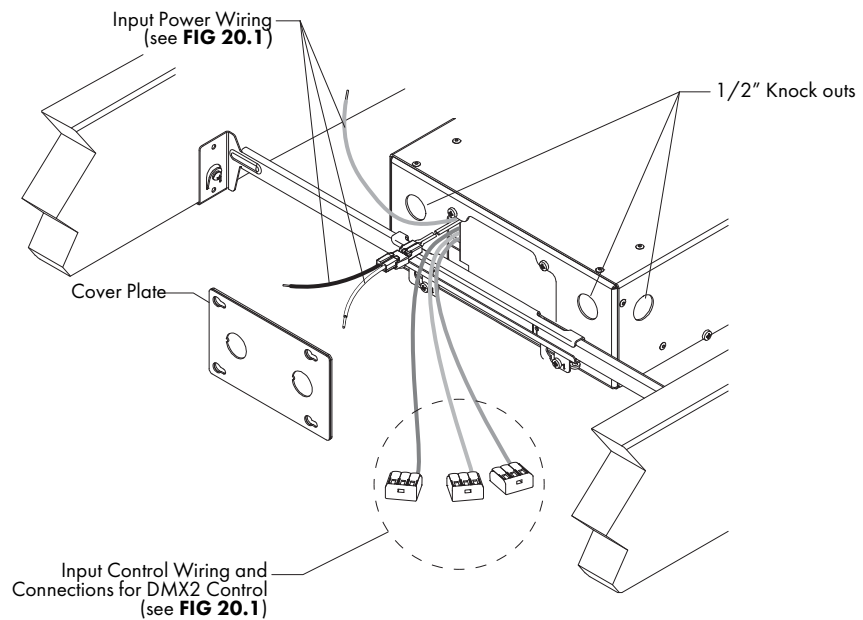

NOTE: For compatible dimmers for use with **DMX2** drivers see www.8lighting.com/resources-downloads/

FIG 20.2 Wire Connections



www.8lighting.com

Number Eight Lighting Company

526 Portal Street, Cotati, CA 94931

Phone (707) 794-0888 • Email customerservice@8lighting.com