



800 SERIES
805 SUPER SHALLOW SINGLE and MULTI-LAMP
INSTALLATION INSTRUCTIONS



SCAN QR CODE FOR INSTRUCTIONS

WARNING: Read and understand these instructions completely before installation. To be installed by qualified electricians only. Products should be installed in accordance with these instructions, local electrical codes, and the National Electric Code (NEC). These products may represent a possible shock or fire hazard if improperly installed.

CAUTION: Disconnect power at circuit breaker or fuse panel before installation or servicing. Always allow LED assembly to cool before servicing. Do not connect or disconnect LED lamp module wire connector when fixture is energized as this may result in permanent damage to the LED. Do not install where insulation or ambient temperatures will exceed maximum values noted in product specifications. See www.8lighting.com for current product specifications.

NOTE: Number Eight Lighting fixtures are designed to meet the latest NEC requirements and are listed in full compliance with UL standards. Before attempting installation, check your local electrical code which sets the wiring standards and installation requirements for your locality and should be understood before starting work.

SAVE THESE INSTRUCTIONS.

TABLE OF CONTENTS

	PAGE
HOUSING INSTALLATION - BAR HANGER MOUNTING.....	1-3
HOUSING INSTALLATION - PANEL MOUNTING BRACKET.....	4
HOUSING INSTALLATION - T-BAR MOUNTING.....	5
HOUSING INSTALLATION - BUTTERFLY BRACKET MOUNTING.....	6
CEILING CUT-OUTS - PLASTER/SHEETROCK CEILINGS.....	7
CEILING CUT-OUTS - WOOD/STONE/ACOUSTIC TILE CEILINGS.....	8
J5 LAMP MODULE ADJUSTMENT, REMOVAL & REPLACEMENT.....	9
J5 LAMP MODULE VERTICAL AIMING RANGE.....	10-11
K5 & W5 LAMP MODULE ADJUSTMENT, REMOVAL & REPLACEMENT.....	12
J5 & W5 LAMP MODULE WALL WASH ADJUSTMENT.....	13
POWER SUPPLY ACCESS & REPLACEMENT.....	14-15
WIRING INSTRUCTIONS.....	16
WIRING DIAGRAMS.....	17-20

HOUSING INSTALLATION

Bar Hanger Mounting

STEP 1 Important: Before attaching Hanger Brackets you must determine Trim Model to be used (refer to Trim Types on **Pages 7-8**). Select upper or lower Bracket hole position (refer to **Table 1.1 Hanger Bracket Position Chart**).

Note: Ceiling thickness is measured from bottom face of ceiling joist to bottom face of ceiling. Refer to **800 Series** trim installation instructions (92005) for additional details - see www.8lighting.com/resources-downloads/.

STEP 2 Loosen 2 screws slightly on Housing to attach or adjust each Hanger Bracket. Position Hanger Bracket in hole position #1 or #2 and secure screws – **FIG 1.1** and **1.2**.

STEP 3 Assemble Bar Hanger A and B through each Hanger Bracket to slide onto each other. The ends should have 1" minimum overlap.

Note: Bar Hangers can be shortened at break locations shown – **FIG 1.1**.

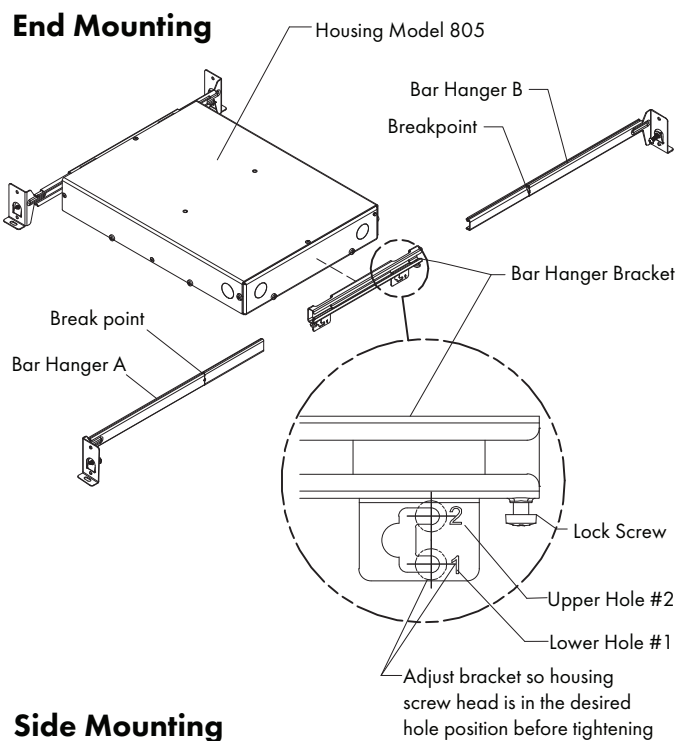

Side Mounting

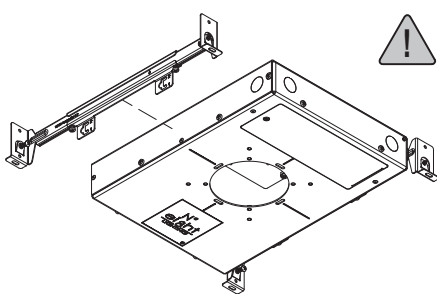

Refer to Table 1.1 above.

800 Series Trim Models	For Ceiling Thickness Range	Hole Position #
FR-P, FS-P	1/2" to 1"	Lower #1
INR-P, INS-P, INR-BV-P, INS-BV-P	1/2" to 1"	Upper #2
	1" to 1-1/2"	Lower #1
FS-W, FS-W-M, FLS-W	1/4" to 3/4"	Upper #2
	3/4" to 1-1/2"	Lower #1
INS-W, FLINS-W, INS-BV-W, FLINS-BV-W	1/2" to 1"	Upper #2
	1" to 1-1/2"	Lower #1
FR-W, FR-W-M, FLR-W	Standard Mounting Ring	1/2" to 1"
	Standard Mounting Ring	1" to 1-1/2"
INR-W, FLINR-W, INR-BV-W, FLINR-BV-W	Standard Mounting Ring	1/2" to 3/4"
	Standard Mounting Ring	1" to 1-1/4"
	Tall Mounting Ring	3/4" to 1"
	Tall Mounting Ring	1-1/4" to 1-1/2"

Note: Refer to **Pages 9-11** for J5 Lamp Module adjustment angle range.

IMPORTANT:

Install so Bar Hanger flanges are positioned as shown

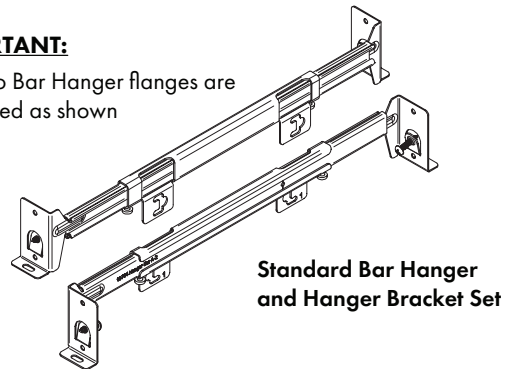

Hole Position Upper #2

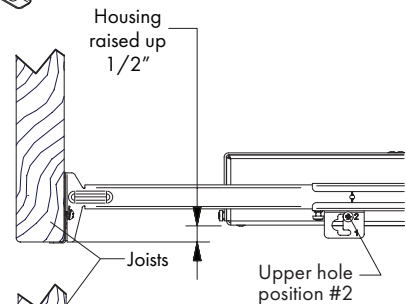

Hole Position Lower #1

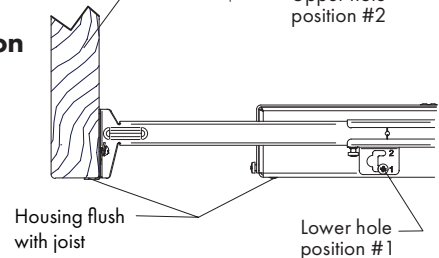

CAUTION:

Be sure to select correct hole position for intended Trim assembly. Changing hole position is not possible after ceiling is installed.

FIG 1.1 Installing Bar Hangers and Hanger Brackets

FIG 1.2 Hole Position and Housing Location

HOUSING INSTALLATION

Bar Hanger Mounting - Multi-lamp Housings

Note: Pre-install Bar Hanger & Bracket sets to housing as shown.
Refer to Page 1 for assembly and positioning details.

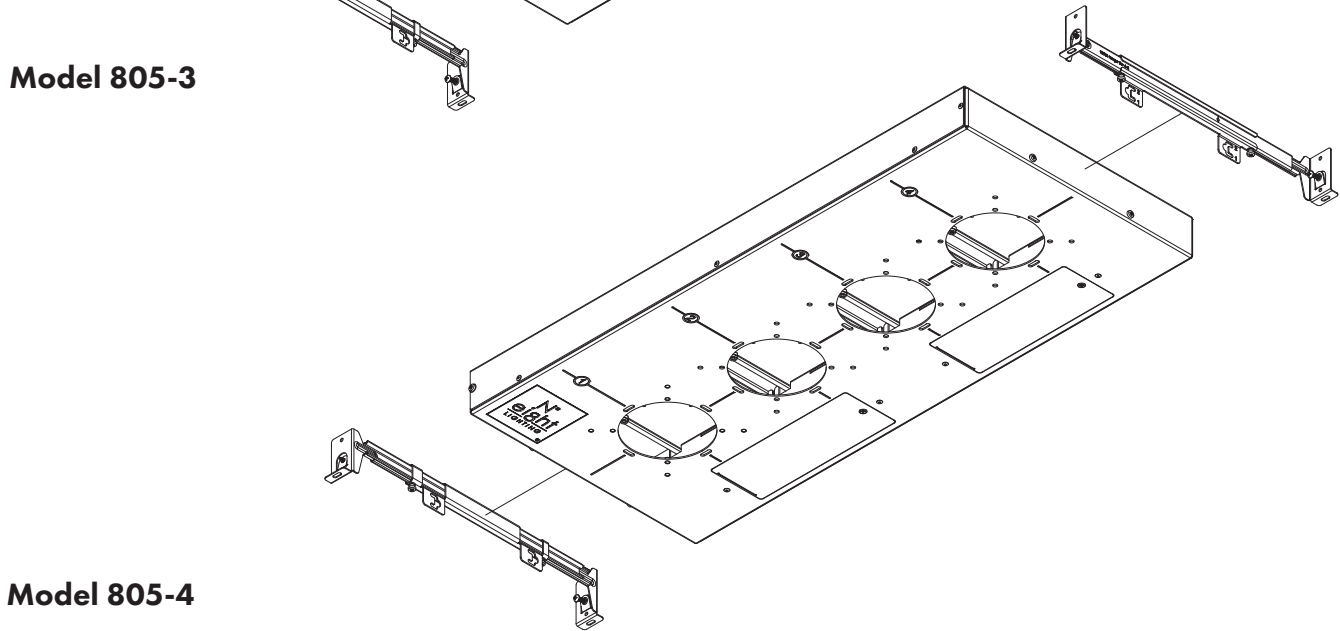
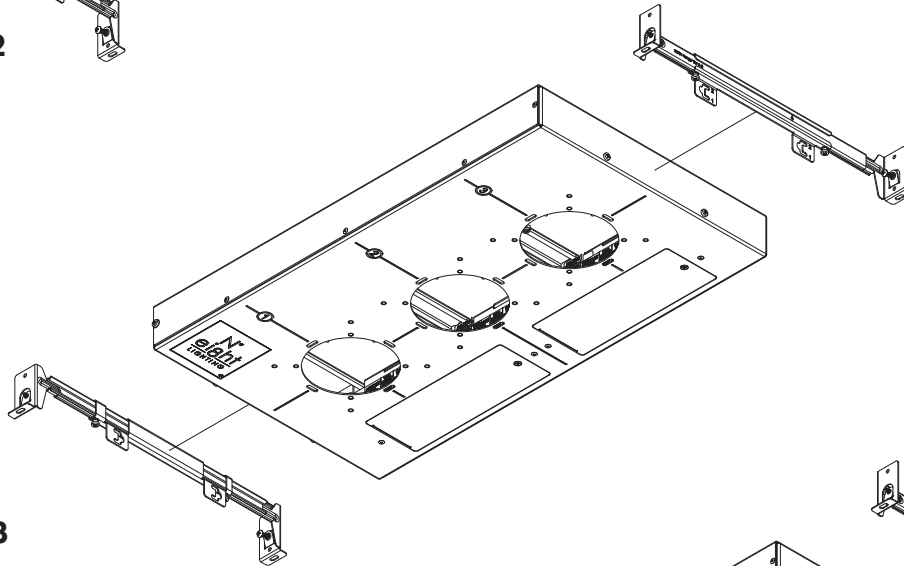
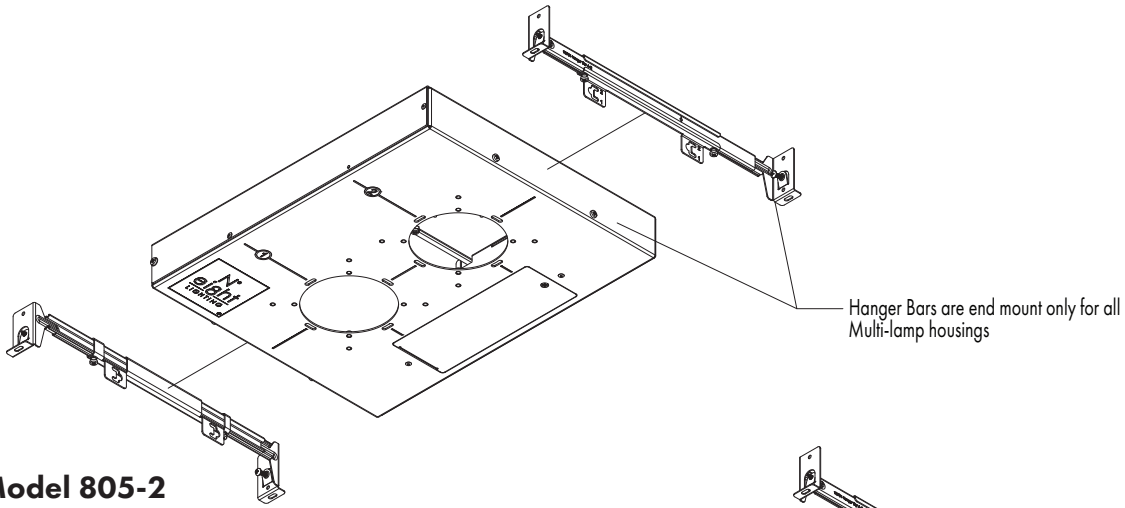

HOUSING INSTALLATION

Mounting Housing To Joists and Sticker Application

STEP 1 Spread Hanger Bars to approximate joist spacing. Temporarily secure Lock Screws to keep Housing from sliding along Hanger Bars – **FIG 3.1 & 2.2.**

Note: For Sloped Ceilings - Installing Housing so J Box Cover faces wall is recommended for maximum adjustment on applicable Lamp Modules – **FIG. 3.3.**

STEP 2 Secure Housing and Hanger Bar assembly to Joists using either the fasteners supplied on Hanger Bars or fasteners through alternate mounting holes – **FIG 3.1.**

STEP 3 Reposition Housing along Hanger Bars as needed. Use guide lines to help locate Housing relative to nearby walls or other fixtures – **FIG 3.1 & 3.2.**

STEP 4 Apply Stickers over unused holes and slots as shown to prevent light leaks and maintain airtight standards compliance. No caulking required – **FIG 3.4.**

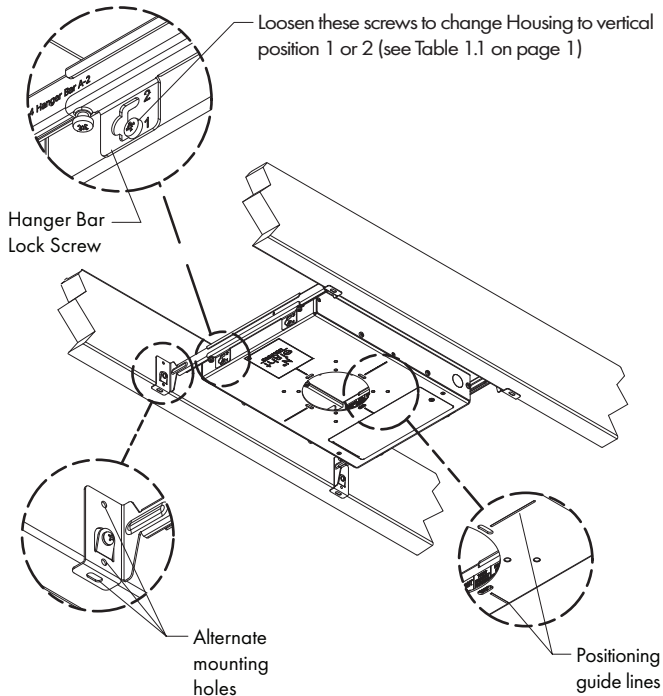

FIG 3.1 Fastening Housing to joists

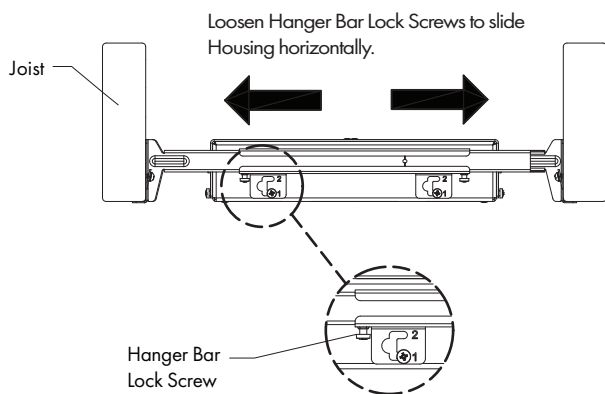

FIG 3.2 Horizontal Housing adjustment

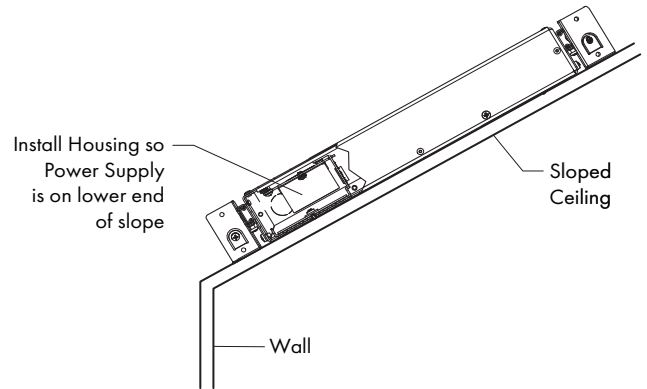
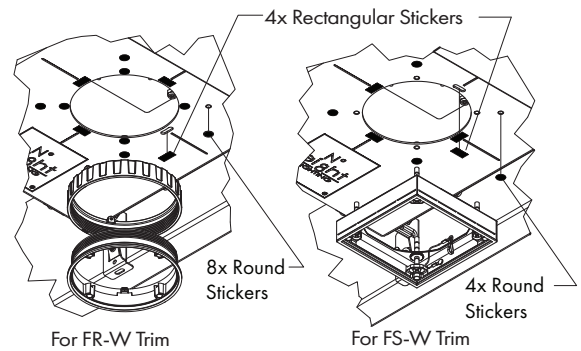

FIG 3.3 Recommended Sloped Ceiling Orientation

! **IMPORTANT** For Airtight Compliance - Stickers are required on all 805 Housings

Wood / Stone Ceiling



Plaster / Sheetrock Ceiling

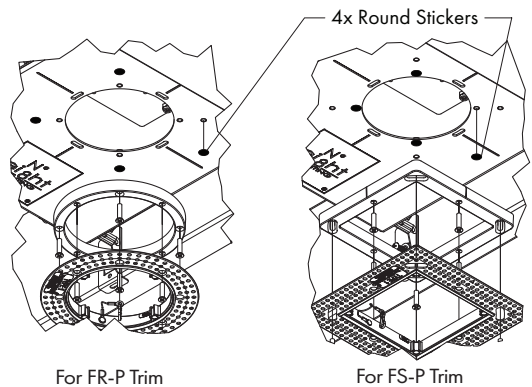

FIG 3.4 Sticker Application

HOUSING INSTALLATION

PMB - Panel Mounting Bracket

CAUTION: Read all instructions completely before proceeding.

Important: Before attaching Panel Mounting Brackets you must determine Trim Model to be used (refer to Trim Types on Pages 7-8).

Note: Panel may consist of wood, stone or other structural material. Sheetrock could also be used attached below panel & must be considered part of the overall ceiling thickness.

STEP 1 Select upper or lower Bracket position (refer to **Table 4.1** Panel Mounting Bracket Position) & attach 2x Panel Mounting Brackets to Housing as shown using screws supplied with Housing (use side or end mounting locations as needed) - **FIG 4.1** & **FIG 4.2**

STEP 2 Locate & cut hole in ceiling panel (refer to Trim types and hole sizes specified on **Pages 7-8**) - **FIG 4.1**.

STEP 3 Align Housing so aperture is centered in ceiling cut-out & secure Panel Mounting Brackets to panel using 4x Screws suitable for mounting surface (not supplied) - **FIG 4.1**.

Table 1.1 Bar Hanger Bracket Position

800 Series Trim Models	For Ceiling Thickness Range	Hole Position #
FR-P, FS-P	1/2" to 1"	Lower #1
INR-P, INS-P, INR-BV-P, INS-BV-P	1/2" to 1"	Upper #2
	1" to 1-1/2"	Lower #1
FS-W, FS-W-M, FLS-W	1/4" to 3/4"	Upper #2
	3/4" to 1-1/2"	Lower #1
INS-W, FLINS-W, INS-BV-W, FLINS-BV-W	1/2" to 1"	Upper #2
	1" to 1-1/2"	Lower #1
FR-W, FR-W-M, FLR-W	Standard Mounting Ring	1/2" to 1"
		1" to 1-1/2"
INR-W, FLINR-W, INR-BV-W FLINR-BV-W	Standard Mounting Ring	1/2" to 3/4"
		1" to 1-1/4"
	Tall Mounting Ring	3/4" to 1"
		1-1/4" to 1-1/2"

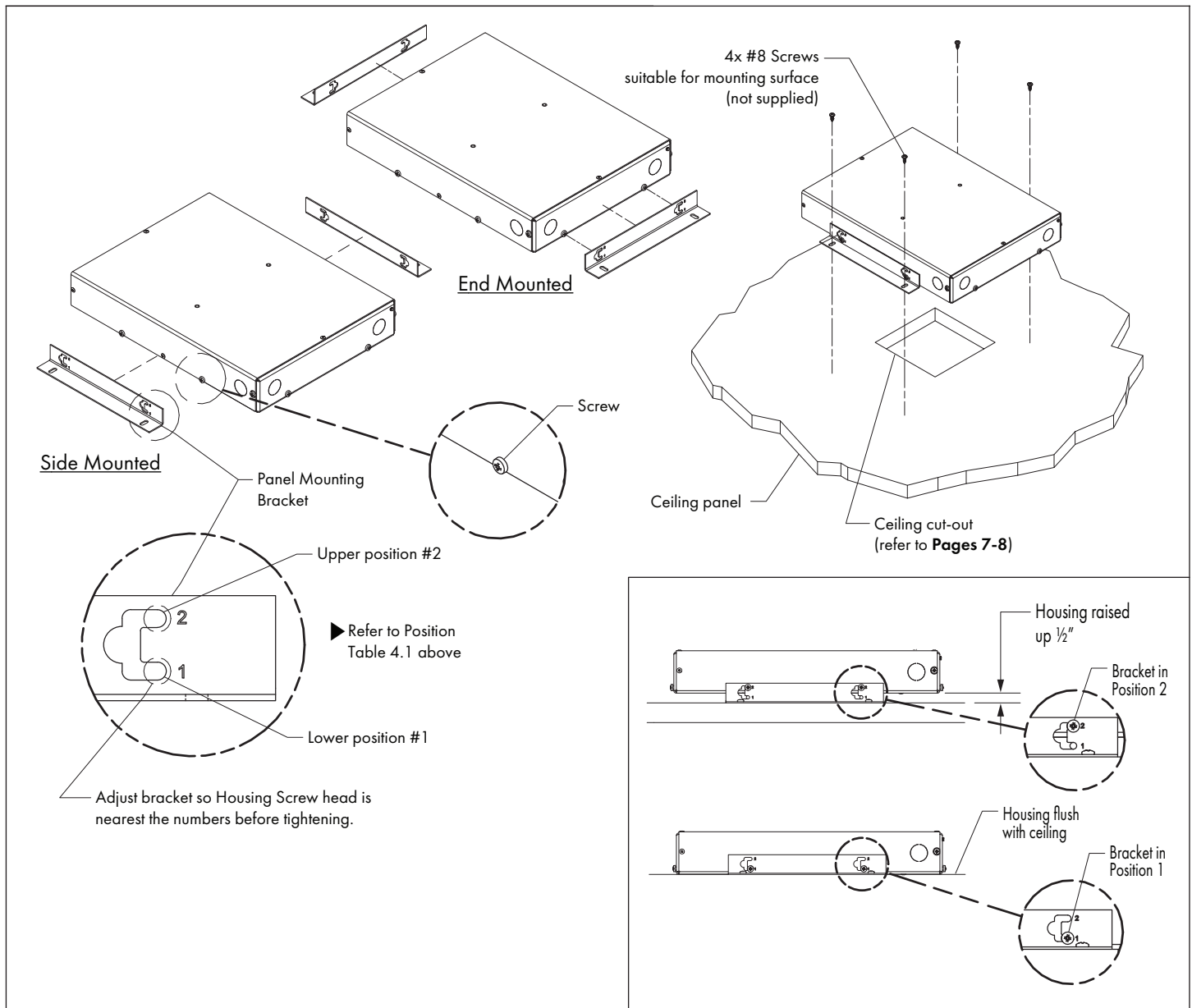

FIG 4.1 Install Panel Mounting Brackets

FIG 4.2 Panel Mounting Bracket Position

HOUSING INSTALLATION

TBC - T-BAR Clips for T-GRID Mounting with Bar Hangers

Important: Before attaching Bar Hangers you must determine Trim Model to be used (refer to Trim Types on Pages 7-8).

STEP 1 Pre-assemble T-Grid Clips to Bar Hangers & tighten Bar Hanger Mounting Screws just enough to allow for vertical adjustment of Hanger Bracket - **FIG 5.1**.

STEP 2 Attach Bar Hanger Brackets to Housing in hole position 1 or 2 to accommodate Trim Model & ceiling tile thickness (refer to Page 4 - Table 4.1) - **FIG. 5.2**.

CAUTION: Hanger Bar hole position cannot be changed after ceiling is installed.

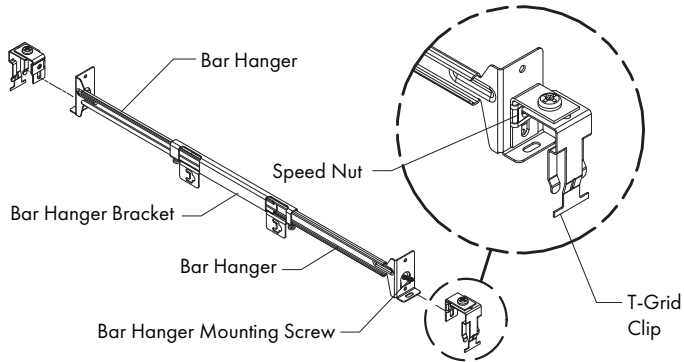

FIG 5.1 Attach T-Grid Clip assemblies to Hanger Bracket Assemblies

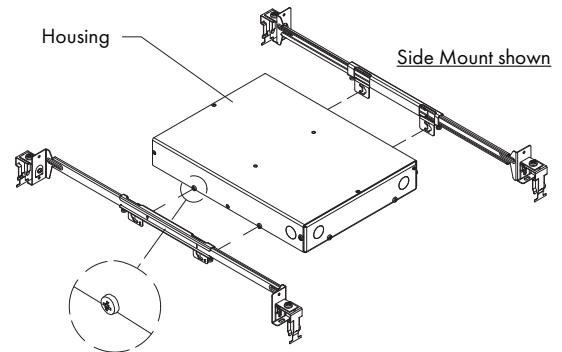

FIG 5.2 Attach Hanger Bracket Assemblies to Housing

STEP 3 Extend Hanger bars to position T-Grid Clip assemblies fixture onto T-Grid bars - **FIG 5.4**.

STEP 4 Determine cut-out location in Ceiling Tile and ensure sufficient clearance for housing installation. Locate & cut hole in Ceiling Tile (refer to Trim Types and hole sizes specified on Pages 7-8). Install Ceiling Tile into T-Grid - **FIG 5.5**.

STEP 5 Attach fixture to T-Grid and adjust horizontal fixture position so Housing aperture is centered with Ceiling Tile opening. Lock fixture into place by tightening the Bar Hanger Lock Screws - **FIG 5.5**.

STEP 6 Adjust vertical height of Housing by sliding speed nuts so Housing is level with Ceiling Tile. Lock position by tightening Mounting Screws - **FIG 5.6**.

Note: Trim will permit a vertical adjustment range to help accommodate Ceiling Tile thickness.

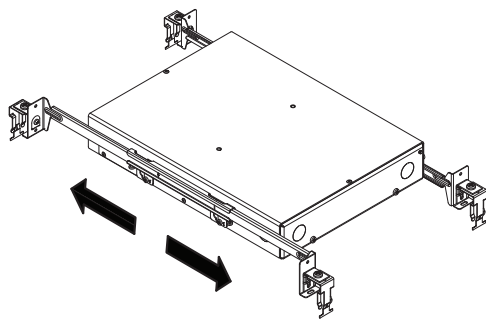

FIG 5.3 Adjust Hanger Bars

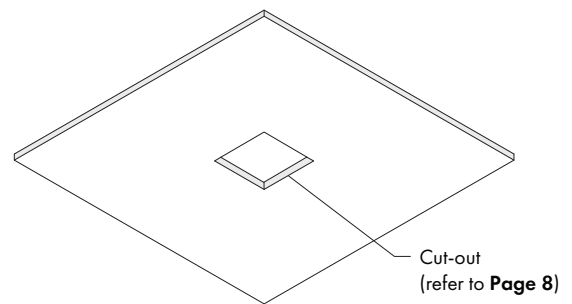

FIG. 5.4 Cut opening in Ceiling Tile

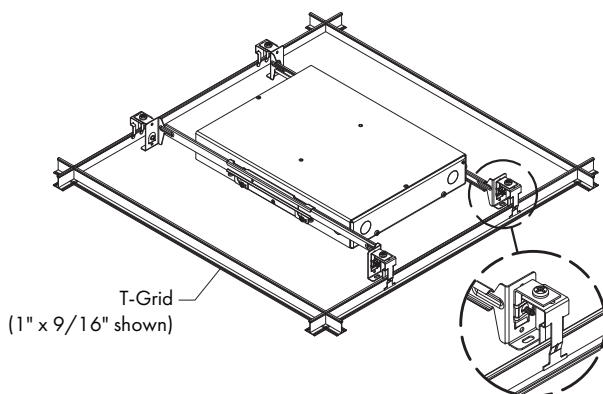

FIG 5.5 Attach to T-Grid

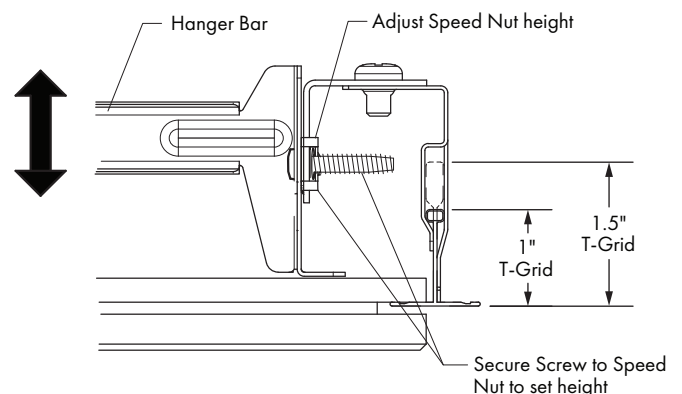

FIG 5.6 Adjust vertical Housing height

INSTALLATION INSTRUCTIONS

BB - Butterfly Bracket - For Commercial C-CHANNEL or T-GRID Mounting

STEP 1 Attach Butterfly Brackets to either ends or sides of mounting frame using existing screws - **FIG 6.2**.

STEP 2 Slide c-channel or bar through bracket and adjust height with thumb screw - **FIG 6.3**.

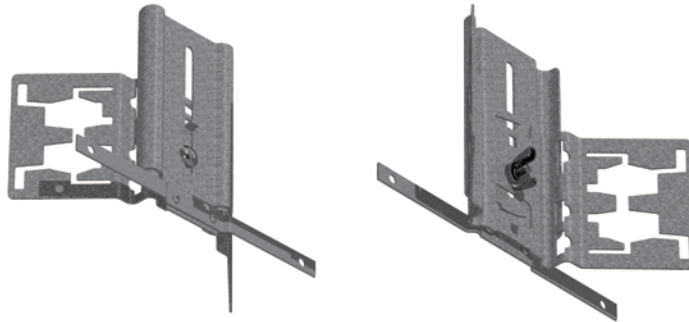

FIG 6.1 Butterfly Brackets (1 Set)

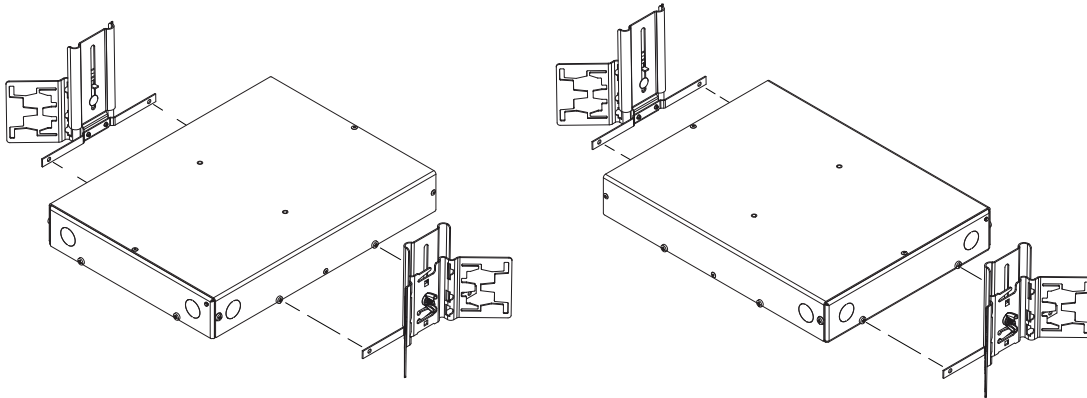

FIG 6.2 Butterfly Bracket/Housing Position

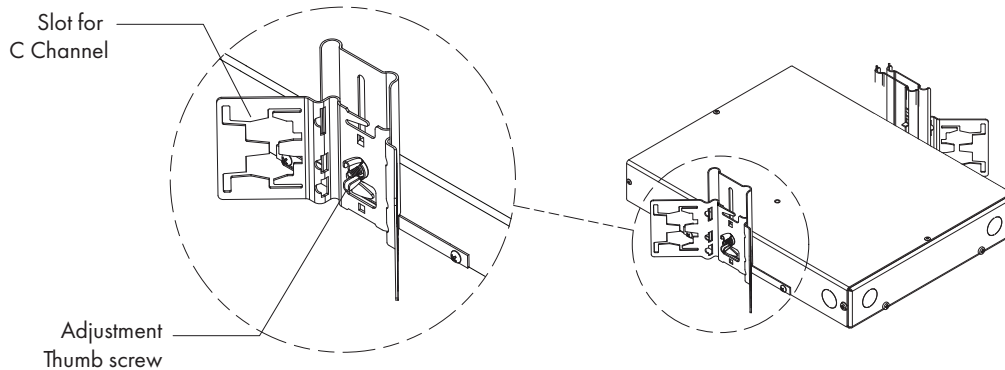
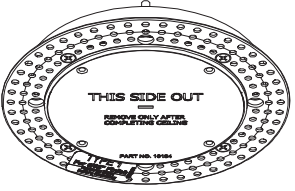
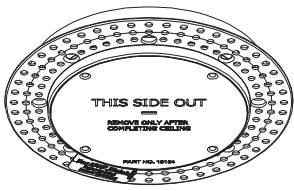
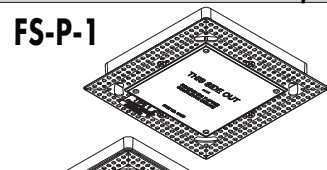
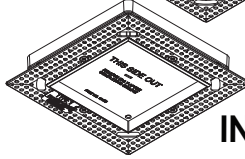
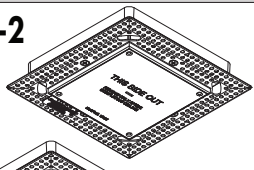
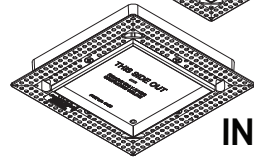
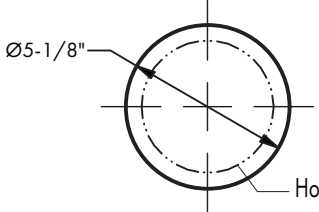
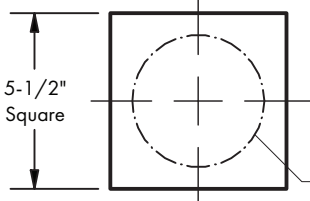
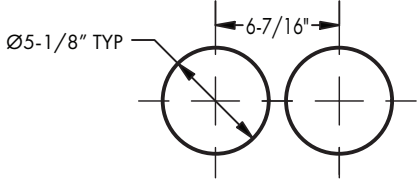
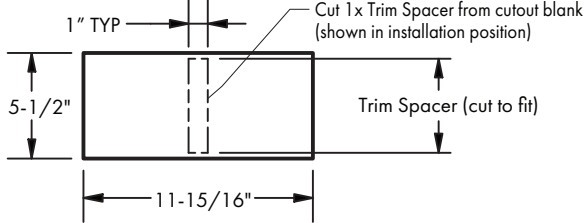
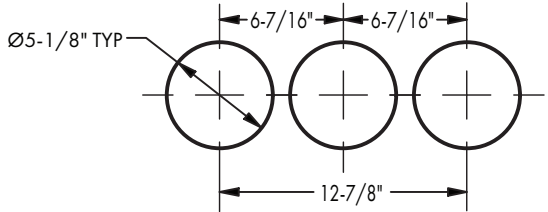
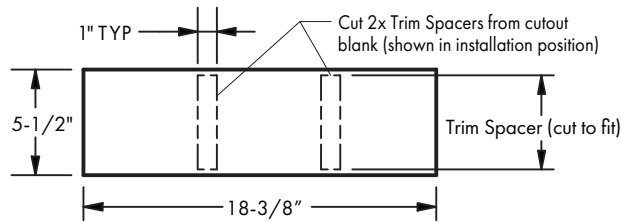
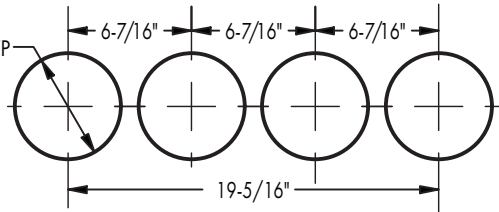
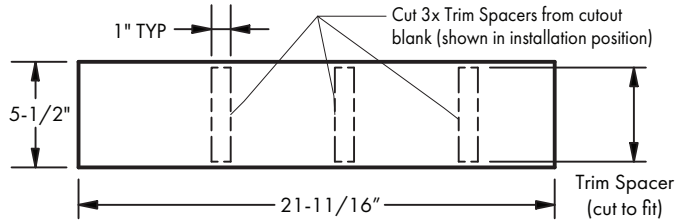

FIG 6.3 Butterfly Bracket Adjustment

CEILING CUTOUTS FOR PLASTER/SHEETROCK CEILINGS

Refer to 800 Series Trim Installation Instructions (92005) for Additional Details

Round Trims		Square Trims		
Trim Model	 <p>FR-P-1</p>	 <p>FR-P-2</p>	 <p>FS-P-1</p>  <p>INS-P-1</p>	 <p>FS-P-2</p>  <p>INS-P-2</p>
1 Lamp Housing	<p>Round Trim Cutouts</p>  <p>Ø5-1/8"</p> <p>Housing aperture</p> <p>(shown at larger scale)</p>		<p>Square Trim Cutouts & Spacers</p>  <p>5-1/2" Square</p> <p>Housing aperture</p> <p>(shown at larger scale)</p>	
2 Lamp Housing	 <p>Ø5-1/8" TYP</p> <p>6-7/16"</p>		 <p>1" TYP</p> <p>Cut 1x Trim Spacer from cutout blank (shown in installation position)</p> <p>5-1/2"</p> <p>Trim Spacer (cut to fit)</p> <p>11-15/16"</p>	
3 Lamp Housing	 <p>Ø5-1/8" TYP</p> <p>6-7/16"</p> <p>6-7/16"</p> <p>12-7/8"</p>		 <p>1" TYP</p> <p>Cut 2x Trim Spacers from cutout blank (shown in installation position)</p> <p>5-1/2"</p> <p>Trim Spacer (cut to fit)</p> <p>18-3/8"</p>	
4 Lamp Housing	 <p>Ø5-1/8" TYP</p> <p>6-7/16"</p> <p>6-7/16"</p> <p>6-7/16"</p> <p>19-5/16"</p>		 <p>1" TYP</p> <p>Cut 3x Trim Spacers from cutout blank (shown in installation position)</p> <p>5-1/2"</p> <p>Trim Spacer (cut to fit)</p> <p>21-11/16"</p>	

CEILING CUTOUTS FOR WOOD/STONE/ACOUSTIC TILE CEILINGS

Refer to 800 Series Trim Installation Instructions (92005) for Additional Details

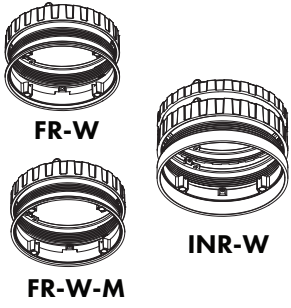
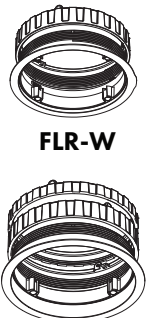
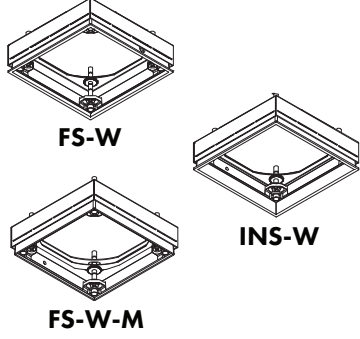
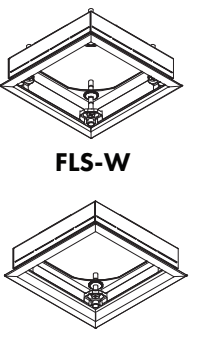
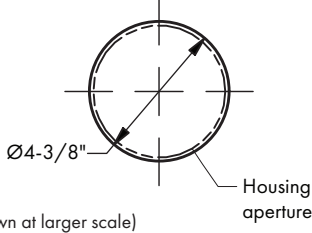
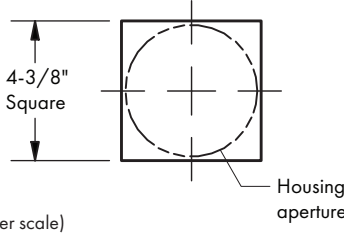
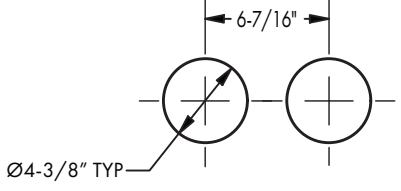
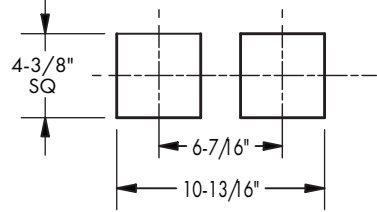
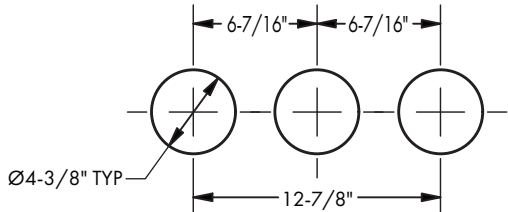
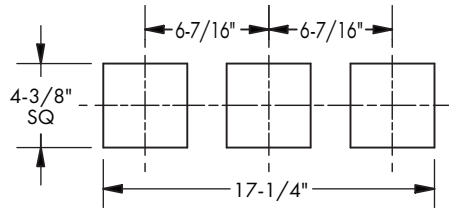
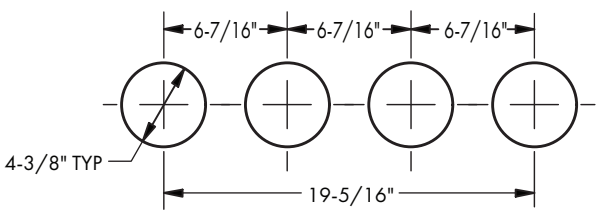
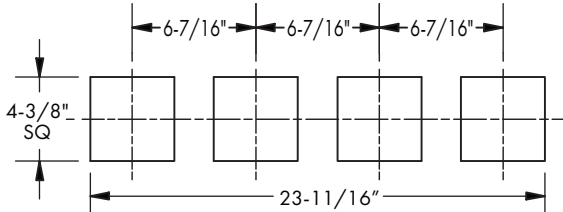
	Round Trims		Square Trims	
	Non-Flanged	Flanged	Non-Flanged	Flanged
Trim Model	 <p>FR-W INR-W FR-W-M</p> <p>Important: All Non-flanged cutouts to have clean, sharp edges</p>	 <p>FLR-W FLNR-W</p>	 <p>FS-W INS-W FS-W-M</p> <p>Important: All Non-flanged cutouts to have clean, sharp edges</p>	 <p>FLS-W FLNS-W</p>
1 Lamp Housing	 <p>(shown at larger scale)</p> <p>Housing aperture</p>	<p>All Round Cutout Tolerances:</p> <p>FR-W, FR-W-M $\pm 1/32''$ INR-W $\pm 1/32''$ FLR-W $+1/8'' / -1/32''$ FLNR-W $+1/8'' / -1/32''$ CTR to CTR $\pm 1/32''$</p>	 <p>(shown at larger scale)</p> <p>Housing aperture</p>	<p>All Square Cutout Tolerances:</p> <p>FS-W, FS-W-M $\pm 1/32''$ INS-W $\pm 1/32''$ FLS-W $+1/8'' / -1/16''$ FLNS-W $+1/8'' / -1/16''$ CTR to CTR $\pm 1/32''$</p>
2 Lamp Housing	 <p>$\text{Ø}4\text{-}3/8''$ TYP</p> <p>$6\text{-}7/16''$</p>	 <p>$4\text{-}3/8''$ SQ</p> <p>$6\text{-}7/16''$</p> <p>$10\text{-}13/16''$</p>		
3 Lamp Housing	 <p>$\text{Ø}4\text{-}3/8''$ TYP</p> <p>$6\text{-}7/16''$</p> <p>$12\text{-}7/8''$</p>	 <p>$4\text{-}3/8''$ SQ</p> <p>$6\text{-}7/16''$</p> <p>$17\text{-}1/4''$</p>		
4 Lamp Housing	 <p>$4\text{-}3/8''$ TYP</p> <p>$6\text{-}7/16''$</p> <p>$19\text{-}5/16''$</p>	 <p>$4\text{-}3/8''$ SQ</p> <p>$6\text{-}7/16''$</p> <p>$23\text{-}11/16''$</p>		

LAMP MODULE INSTRUCTIONS

J5 Lamp Module Adjustment, Removal, and Replacement

Aiming and Adjustment

STEP 1 Loosen (DO NOT REMOVE) Horizontal Lock Screw and rotate the entire J5 lamp Module to desired horizontal rotation adjustment.

Use Horizontal Lock Screw to secure the horizontal adjustment - **FIG 9.1**.

STEP 2 Loosen Vertical Lock Knob and adjust J5 Lamp Module to desired vertical aiming position. Tighten Lock Knob to secure the vertical adjustment - **FIG 9.1**.

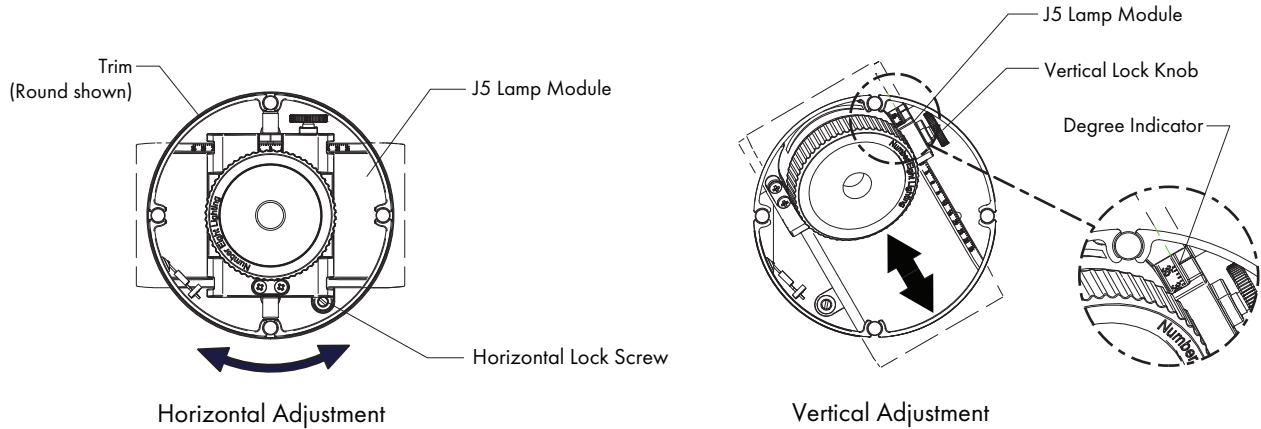

FIG 9.1 J5 Aiming Adjustment

Removal

STEP 1 Remove Trim Plate. Unscrew Lens Ring and Optic Assembly and remove from Snoot. Loosen Vertical Stop Knob and adjust Lamp Module to 30° to position Key Slot over the Mounting Screw as shown - **FIG 9.2**.

STEP 2 Loosen 1/8" Hex Mounting Screw (DO NOT REMOVE) using 1/8" Hex Key through Key Slot in Snoot. Remove J5 Lamp Module through trim aperture and disconnect wire connectors - **FIG 9.2 & 9.3**.

Replacement

STEP 1 Replace existing J5 Lamp Module by following removal instructions above.

STEP 2 Install J5 Lamp Module through trim aperture and connect wire connectors making sure not to trap wiring underneath - **FIG 9.3**.

STEP 3 Fasten Mounting Screw into threaded hole using 1/8" Hex Torque Driver set to 1.5 Nm (DO NOT OVERTIGHTEN). For 1/8" Hex Torque Driver details, contact Number Eight Lighting Customer Service at www.8lighting.com - **FIG 9.2**.

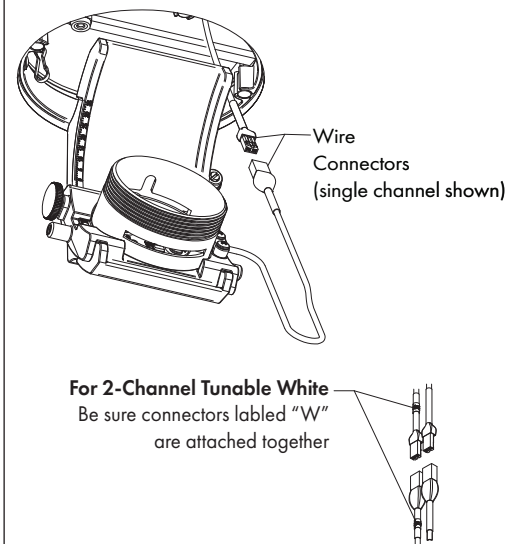
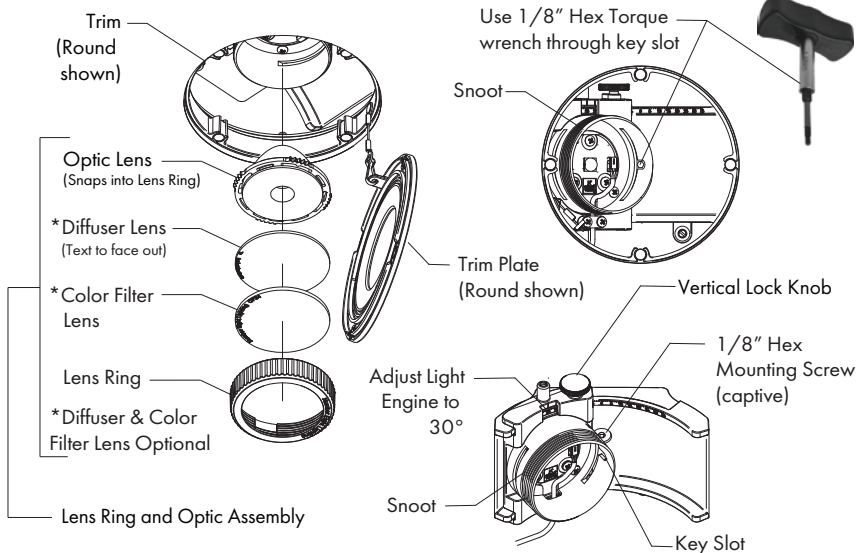

FIG 9.2 J5 Lamp Module Mounting

FIG 9.3 Remove/Replace J5 Lamp Module

LAMP MODULE INSTRUCTIONS

J5 Lamp Module Vertical Aiming Range - Plaster Ceiling Trims

800 Series Trim Models	Ceiling Thickness	HB Hole Position *	Overall Trim Depth Trim	Maximum Vertical Aiming Angle No Trim Plate Lens			Maximum Vertical Aiming Angle With Trim Plate Lens		
				No Accessory	1 Accessory	2 Accessory	No Accessory	1 Accessory	2 Accessory
FR-P, FS-P	1/2"	1	1/2"	34°	30°	29°	30°	25°	24°
	5/8"	1	5/8"	35°	35°	35°	35°	30°	28°
	3/4"	1	3/4"	35°	35°	35°	35°	34°	31°
	1"	1	1"	35°	35°	35°	35°	35°	35°
INR-P, INS-P	1/2"	2	1"	34°	34°	34°	35°	30°	28°
	5/8"	2	1-1/8"	35°	35°	35°	35°	35°	33°
	3/4"	2	1-1/4"	35°	35°	35°	35°	35°	35°
INR-P, INS-P	1"	1	1"	34°	34°	34°	35°	30°	28°
	1-1/8"	1	1-1/8"	35°	35°	35°	35°	35°	33°
	1-1/4"	1	1-1/4"	35°	35°	35°	35°	35°	35°
INR-BV-P, INS-BV-P	1-1/2"	1	1-1/2"	35°	35°	35°	35°	35°	35°
	1/2"	2	1"	32°	26°	26°	32°	25°	24°
	5/8"	2	1-1/8"	35°	32°	31°	35°	31°	30°
	3/4"	2	1-1/4"	35°	35°	35°	35°	35°	34°
INR-BV-P, INS-BV-P	1"	2	1-1/2"	35°	35°	35°	35°	35°	35°
	1"	1	1"	32°	26°	26°	32°	25°	24°
	1-1/8"	1	1-1/8"	35°	32°	31°	35°	31°	30°
	1-1/4"	1	1-1/4"	35°	35°	35°	35°	35°	34°
INR-BV-P, INS-BV-P	1-1/2"	1	1-1/2"	35°	35°	35°	35°	35°	35°

*Hanger Bar Position 1 = Housing Flush w/ Face of Framing. Hanger Bar Position 2 = Housing 1/2" Above Face of Framing.

J5 Lamp Module Vertical Aiming Range - SQUARE Wood Ceiling Trims

800 Series Trim Models	Ceiling Thickness	HB Hole Position *	Overall Trim Depth Trim	Maximum Vertical Aiming Angle No Trim Plate Lens			Maximum Vertical Aiming Angle With Trim Plate Lens		
				No Accessory	1 Accessory	2 Accessory	No Accessory	1 Accessory	2 Accessory
FS-W, FS-W-M, FLS-W	1/4"	2	3/4"	35°	34°	31°	32°	28°	25°
	3/8"	2	7/8"	35°	35°	35°	35°	34°	29°
	1/2"	2	1"	35°	35°	35°	35°	35°	35°
	5/8"	2	1-1/8"	35°	35°	35°	35°	35°	35°
	3/4"	2	1-1/4"	35°	35°	35°	35°	35°	35°
FS-W, FS-W-M, FLS-W	3/4"	1	3/4"	35°	34°	31°	32°	28°	25°
	7/8"	1	7/8"	35°	35°	35°	35°	34°	29°
	1"	1	1"	35°	35°	35°	35°	35°	35°
	1-1/8"	1	1-1/8"	35°	35°	35°	35°	35°	35°
	1-1/4"	1	1-1/4"	35°	35°	35°	35°	35°	35°
INS-W, FLINS-W	1-1/2"	1	1-1/2"	35°	35°	35°	35°	35°	35°
	1/2"	2	1"	34°	29°	27°	29°	24°	21°
	5/8"	2	1-1/8"	35°	34°	32°	33°	29°	26°
	3/4"	2	1-1/4"	35°	35°	35°	35°	35°	32°
INS-W, FLINS-W	1"	2	1-1/2"	35°	35°	35°	35°	35°	35°
	1"	1	1"	34°	29°	27°	29°	24°	21°
	1-1/8"	1	1-1/8"	35°	34°	32°	33°	29°	26°
INS-BV-W, FLINS-BV-W	1-1/4"	1	1-1/4"	35°	35°	35°	35°	35°	35°
	1-1/2"	1	1-1/2"	35°	35°	35°	35°	35°	35°
	1/2"	2	1"	24°	20°	20°	23°	18°	16°
	5/8"	2	1-1/8"	28°	25°	22°	27°	25°	20°
INS-BV-W, FLINS-BV-W	3/4"	2	1-1/4"	34°	28°	26°	33°	26°	22°
	1"	2	1-1/2"	35°	35°	35°	35°	35°	35°
	1"	1	1"	24°	20°	20°	23°	18°	16°
	1-1/8"	1	1-1/8"	28°	25°	22°	27°	25°	20°
	1-1/4"	1	1-1/4"	34°	28°	26°	33°	26°	22°
INS-BV-W, FLINS-BV-W	1-1/2"	1	1-1/2"	35°	35°	35°	35°	35°	35°

*Hanger Bar Position 1 = Housing Flush w/ Face of Framing. Hanger Bar Position 2 = Housing 1/2" Above Face of Framing.

LAMP MODULE INSTRUCTIONS

J5 Lamp Module Vertical Aiming Range - ROUND Wood Ceiling Trims

800 Series Trim Models	Mounting Ring	Ceiling Thickness	BH Hole Position*	Overall Trim Depth	Maximum Vertical Aiming Angle No Trim Plate Lens			Maximum Vertical Aiming Angle No Trim Plate Lens		
					No Accessory	1 Accessory	2 Accessory	No Accessory	1 Accessory	2 Accessory
FR-W, FR-W-M, FLR-W	Standard	1/2"	2	1"	35°	35°	35°	35°	35°	35°
		5/8"	2	1-1/8"	35°	35°	35°	35°	35°	35°
		3/4"	2	1-1/4"	35°	35°	35°	35°	35°	35°
		1"	2	1-1/2"	35°	35°	35°	35°	35°	35°
FR-W, FR-W-M, FLR-W	Standard	1"	1	1"	35°	35°	35°	35°	35°	35°
		1-1/8"	1	1-1/8"	35°	35°	35°	35°	35°	35°
		1-1/4"	1	1-1/4"	35°	35°	35°	35°	35°	35°
		1-1/2"	1	1-1/2"	35°	35°	35°	35°	35°	35°
INR-W, FLINR-W	Short	1/2"	2	1"	32°	26°	25°	27°	23°	19°
		5/8"	2	1-1/8"	35°	33°	31°	33°	28°	26°
		3/4"	2	1-1/4"	35°	35°	35°	35°	33°	31°
INR-W, FLINR-W	Short	1"	1	1"	32°	26°	25°	27°	23°	19°
		1-1/8"	1	1-1/8"	35°	33°	31°	33°	28°	26°
		1-1/4"	1	1-1/4"	35°	35°	35°	35°	33°	31°
INR-W, FLINR-W	Tall	3/4"	2	1-1/4"	35°	35°	35°	35°	33°	31°
		1"	2	1-1/2"	35°	35°	35°	35°	35°	35°
INR-BV-W, FLINR-BV-W	Tall	1-1/4"	1	1-1/4"	35°	35°	35°	35°	33°	31°
		1-1/2"	1	1-1/2"	35°	35°	35°	35°	35°	35°
INR-BV-W, FLINR-BV-W	Short	5/8"	2	1-1/8"	30°	27°	26°	30°	25°	21°
		3/4"	2	1-1/4"	34°	32°	30°	33°	30°	27°
INR-BV-W, FLINR-BV-W	Short	1"	1	1"	25°	22°	22°	24°	20°	17°
		1-1/8"	1	1-1/8"	30°	27°	26°	30°	25°	21°
		1-1/4"	1	1-1/4"	34°	32°	30°	33°	30°	27°
INR-BV-W, FLINR-BV-W	Tall	3/4"	2	1-1/4"	34°	32°	30°	34°	30°	27°
		1"	2	1-1/2"	35°	35°	35°	35°	35°	35°
INR-BV-W, FLINR-BV-W	Tall	1-1/4"	1	1-1/4"	34°	32°	30°	34°	30°	27°
		1-1/2"	1	1-1/2"	35°	35°	35°	35°	35°	35°

*Hanger Bar Position 1 = Housing Flush w/ Face of Framing. Hanger Bar Position 2 = Housing 1/2" Above Face of Framing.

LAMP MODULE INSTRUCTIONS

K5 and W5 Lamp Module Adjustment, Removal, and Replacement

W5 Lamp Module Orientation Adjustment

Note: The **W5** Wall Wash Lamp Module can be installed in 4 different orientations at 90° intervals to direct light toward the wall. Two orientations will require Mounting Screws for the Lamp Module to be relocated as shown in **FIG 12.1**.

STEP 1 Loosen Mounting Screws and disengage **W5** Lamp Module. Relocate screws if required - **FIG 12.1 & 12.2**.

STEP 2 Replace Lamp Module into desired orientation making sure slots are fully seated against screws. Re-tighten screws securely (**DO NOT OVERTIGHTEN**) - **FIG 12.3**.

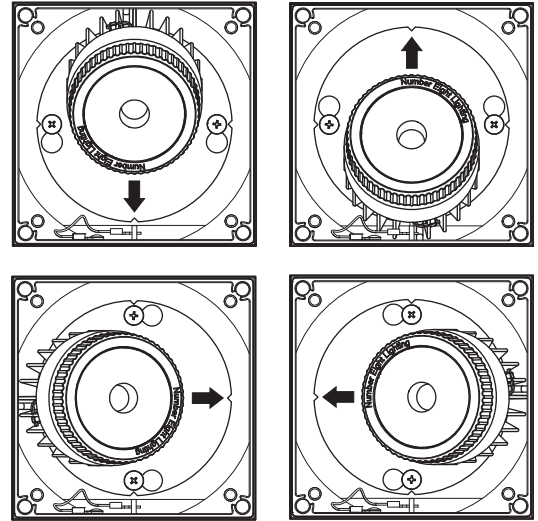
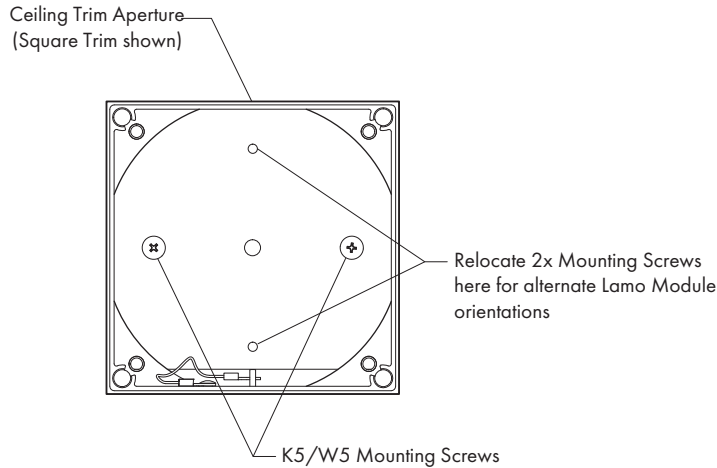

Note: Two of the orientations shown at the right will require the Lamp Module Mounting Screws to be relocated as shown above.

All **W5** Wall Wash Lamp Module orientations possible are shown above. Arrow points towards direction of wall-See **Page 13** for Wall Wash adjustment information.

FIG 12.1 W5 Lamp Module Orientation Adjustment

Removal

STEP 1 Remove Trim Plate and loosen 2x short screws slightly (**DO NOT REMOVE**) - see note below). Slide Lamp Module to disengage from housing - **FIG 12.2**.

STEP 2 Remove Lamp Module and disconnect wire connectors - **FIG 12.3**.

Replacement

Follow steps above in reverse order. **Note:** If replacing **K5** or **W5** Lamp Module with **J5** Lamp Module, remove 2x Lamp Module Mounting Screws shown in **FIG 12.1 & 12.2**.

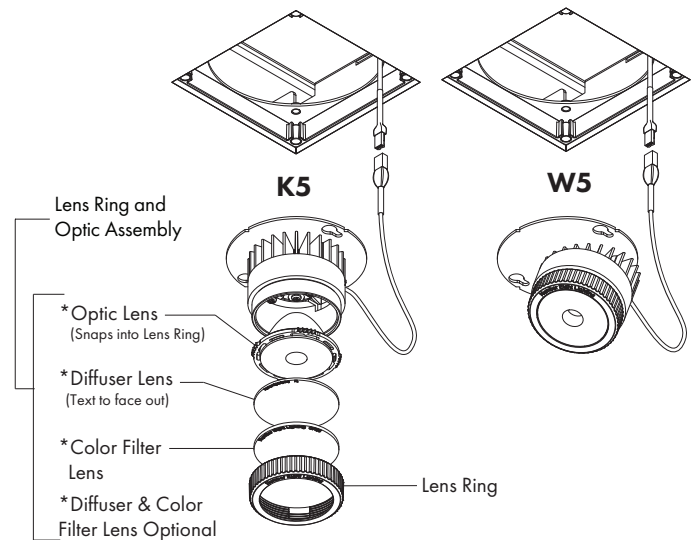
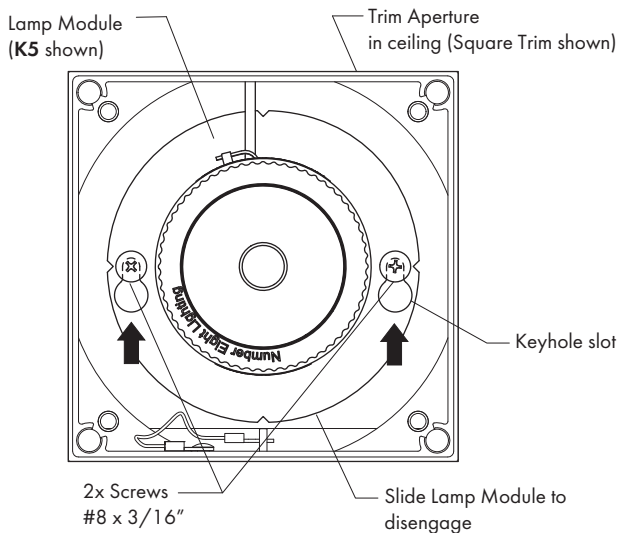

FIG 12.2 K5/W5 Lamp Module Mounting

FIG 12.3 Remove/Replace K5/W5 Lamp Modules

LAMP MODULE INSTRUCTIONS

J5 & W5 Lamp Module Wall Wash Adjustment

J5 & W5 Wall Aiming

STEP 1 For J5 Lamp Module only: Loosen Vertical Lock Knob and adjust to 20° and lock in position - **FIG 13.1**.

STEP 2 Orient J5 or W5 Lamp Module toward wall - **FIG 13.1**. **Note:** For additional W5 orientation details, see **Page 12, FIG 12.1**

STEP 3 Install WW-8 Trim Plate to be aligned to Lamp Module - **FIG 13.2**.

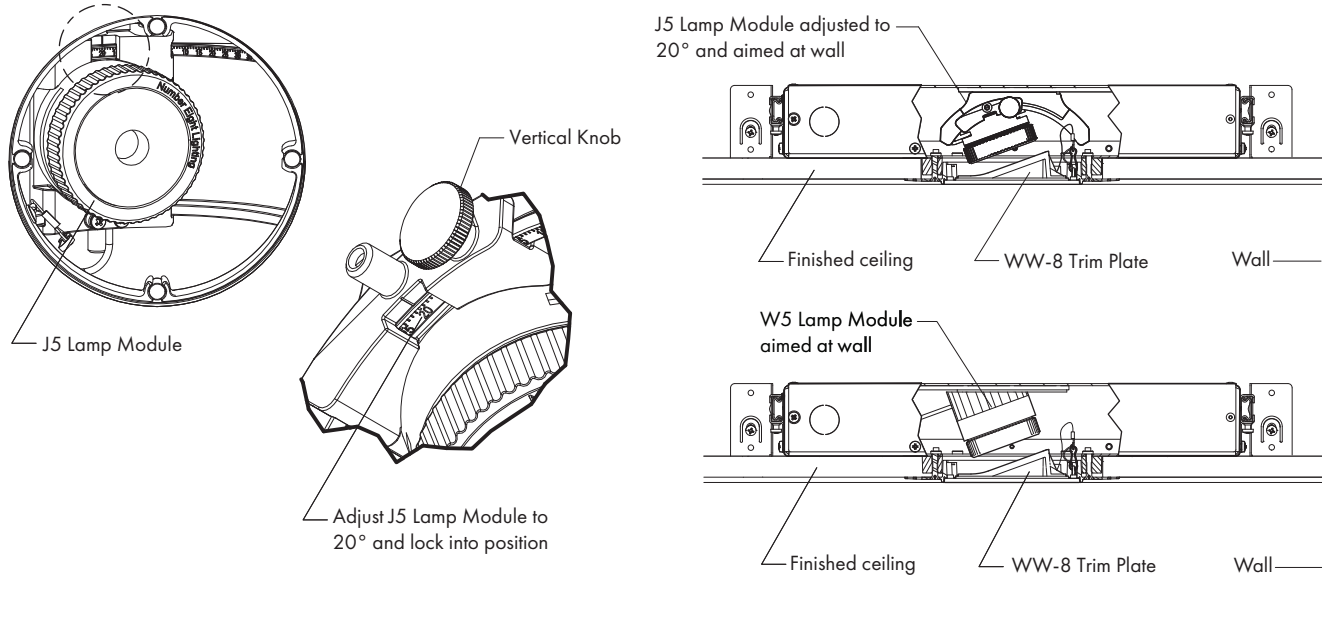

FIG 13.1 Orient Lamp Module with Wall

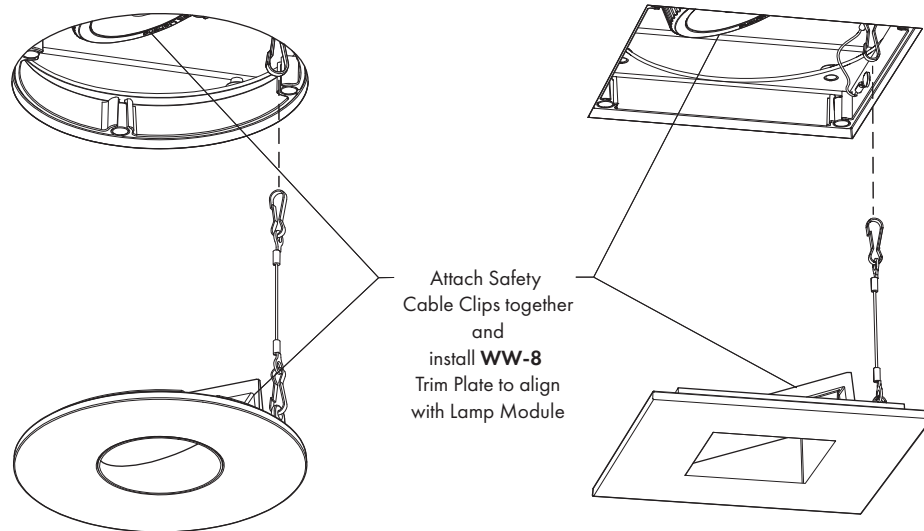

FIG 13.2 Align and Install WW-8 Trim Plate

POWER SUPPLY INSTRUCTIONS

J5 Power Supply Access and Replacement

STEP 1 Adjust Lamp Module to 0° and remove Lens Ring and Optic Assembly as shown in **FIG 14.1**.

STEP 2 Locate and loosen (DO NOT REMOVE) 2x Hex Lock Nuts as shown in **FIG 14.1**.

STEP 3 Move Sliding Bracket along slots to expose Power Supply Module in the aperture (Position 2) - **FIG 14.2**.

STEP 4 Loosen Driver Bracket Screw, remove Power Supply Module through aperture and disconnect wire connections - **FIG 14.2**.

STEP 5 Replace Power Supply Module by following steps above in reverse order. Refer to Wiring Instructions and Diagrams on **Pages 16-20**.

STEP 6 Move Sliding Bracket fully back to properly center Lamp Module (Position 1) and secure Hex Lock Nuts.

STEP 7 Replace Lens Ring and Optic Assembly - See **FIG 14.1**.

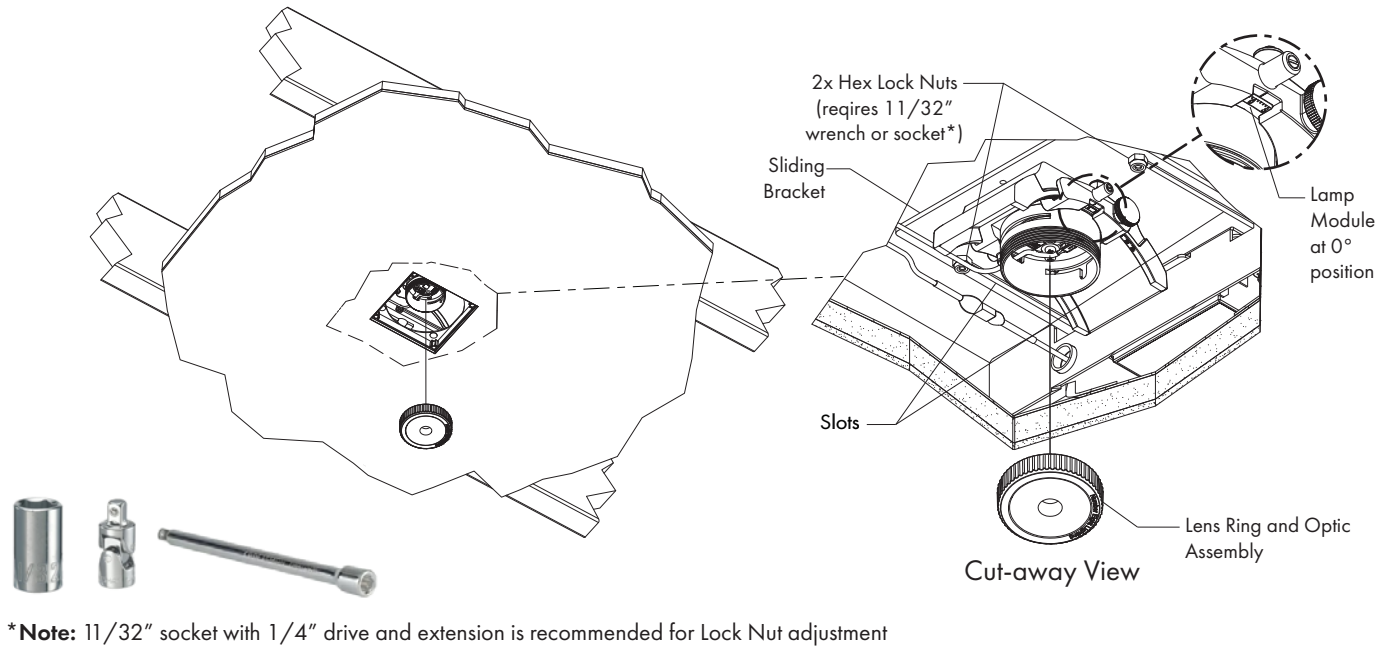

FIG 14.1 Sliding Bracket Adjustment

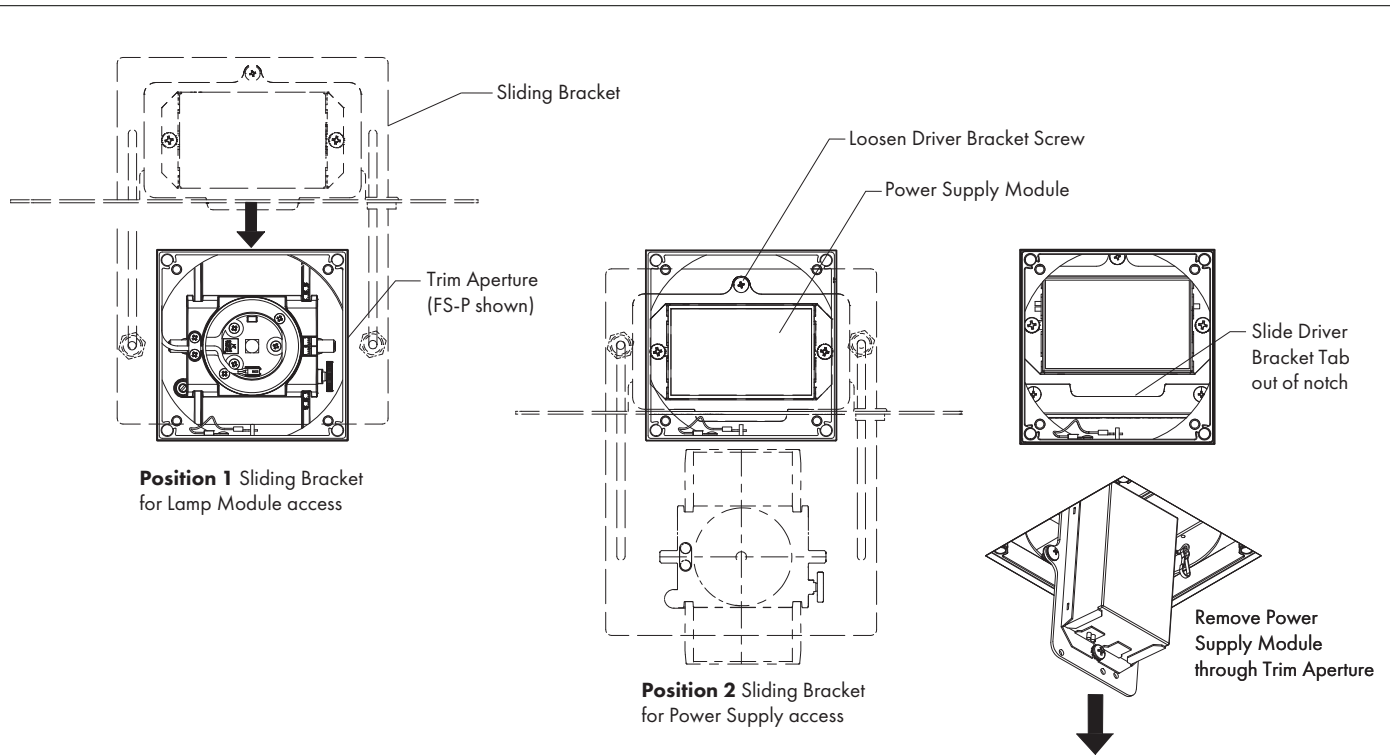
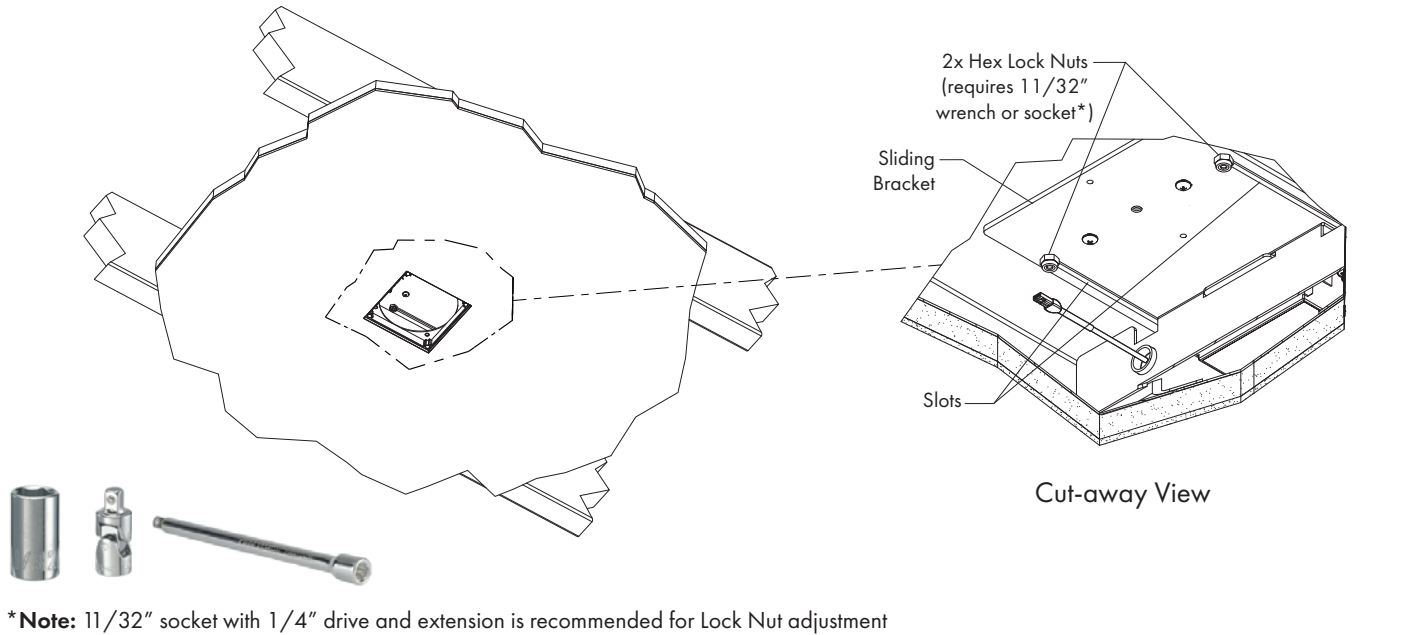

FIG 14.2 Sliding Bracket Positioning and Remove/Replace Power Supply Module

POWER SUPPLY INSTRUCTIONS

K5 and W5 Power Supply Access and Replacement

- STEP 1** Remove Lamp Module as shown on **Page 12, FIG 12.1, 12.2 and 12.3.**
- STEP 2** Locate and loosen (DO NOT REMOVE) 2x Hex Lock Nuts as shown in **FIG 15.1.**
- STEP 3** Move Sliding Bracket along slots to expose Power Supply Module in the aperture (Position 2) - **FIG 15.2.**
- STEP 4** Loosen Driver Bracket Screw, remove Power Supply Module through aperture, and disconnect wire connections - **FIG 15.2.**
- STEP 5** Replace Power Supply Module by following steps above in reverse order. Refer to Wiring Instructions on **Pages 16-20.**
- STEP 6** Move Sliding Bracket fully back to properly center Lamp Module (Position 1) and secure Lock Nuts - **FIG 15.1 and 15.2.**
- STEP 7** Replace Lamp Module - See **Page 12, FIG 12.1, 12.2 and 12.3.**



***Note:** 11/32" socket with 1/4" drive and extension is recommended for Lock Nut adjustment

FIG 15.1 Sliding Bracket Adjustment

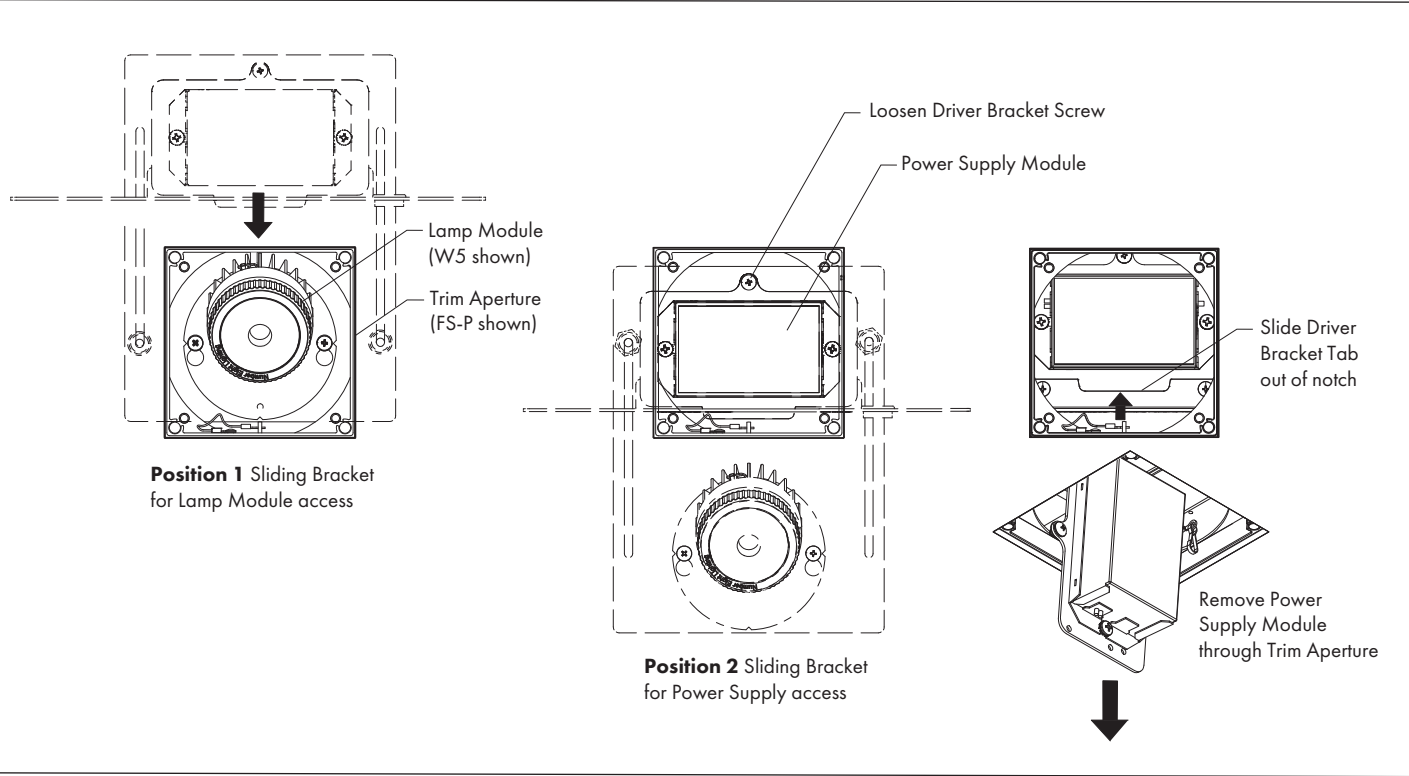

FIG 15.2 Sliding Bracket Positioning and Remove/Replace Power Supply Module

WIRING INSTRUCTIONS

For PR1 / EL1 / EL1-01 / EL2 / EL2-01 / LU4 / DAL2 / DMX2 / DIM6 Driver Options

CAUTION: TO AVOID RISK OF FIRE OR ELECTRIC SHOCK

Turn off power at circuit breaker or fuse panel and read instructions completely before proceeding.

Failure to follow instructions may void warranty. Save these instructions.

- Installation must be by a qualified electrician only and must conform to National Electric code and local regulations.
 - Verify correct dimming system, lamp module, power supply type, and input supply requirements.
 - Always allow LED assembly to cool before servicing.
 - Do not install where insulation or ambient temperatures will exceed maximum values noted in product specifications.
- See www.8lighting.com for current product specifications.

Wiring Access & Wiring

STEP 1 Loosen screw, open Wire Access Cover, and locate supply wiring – **FIG 16.1, 16.2 & 16.3.**

STEP 2 Remove available knock-out in housing and attach supply wire using suitable wire connector - **FIG 16.1 & 16.3.**

Note: Supply wires must extend below housing bottom by 6" min.

STEP 3 Refer to Wiring Diagrams on **Pages 17-20** and wire accordingly.

STEP 4 Install all wiring and connections completely inside wiring compartment - **FIG 16.1, 16.2 & 16.3.**

Note: Ensure supply wiring does not interfere with full movement of Sliding Bracket.

STEP 5 Replace and secure Wire Access Cover - **FIG 16.1 & 16.3.**

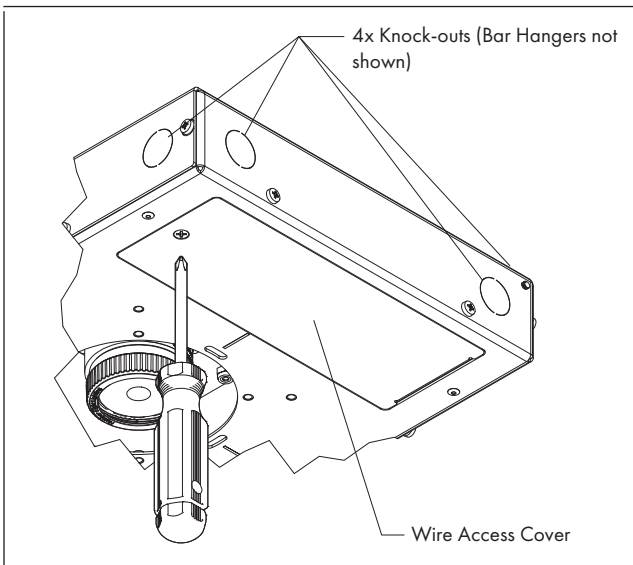

FIG 16.1 Wire Access

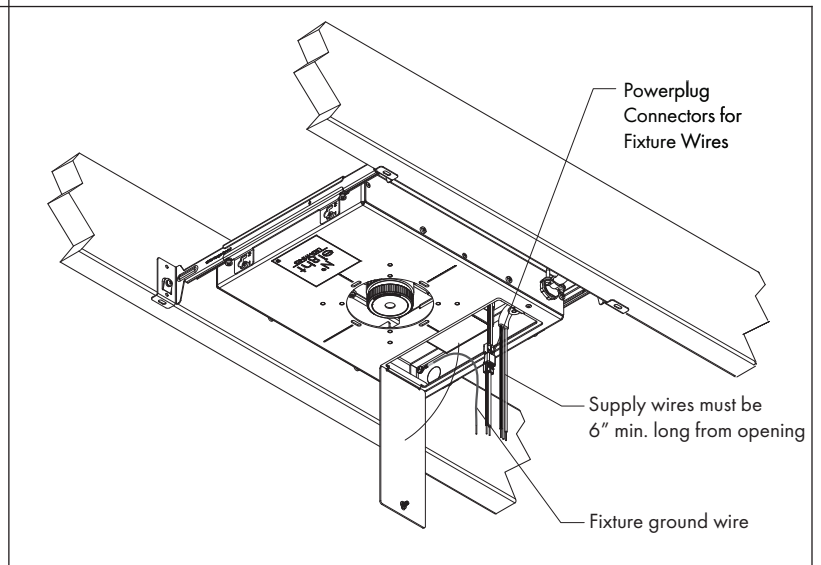

FIG 16.2 Fixture and Supply Wires

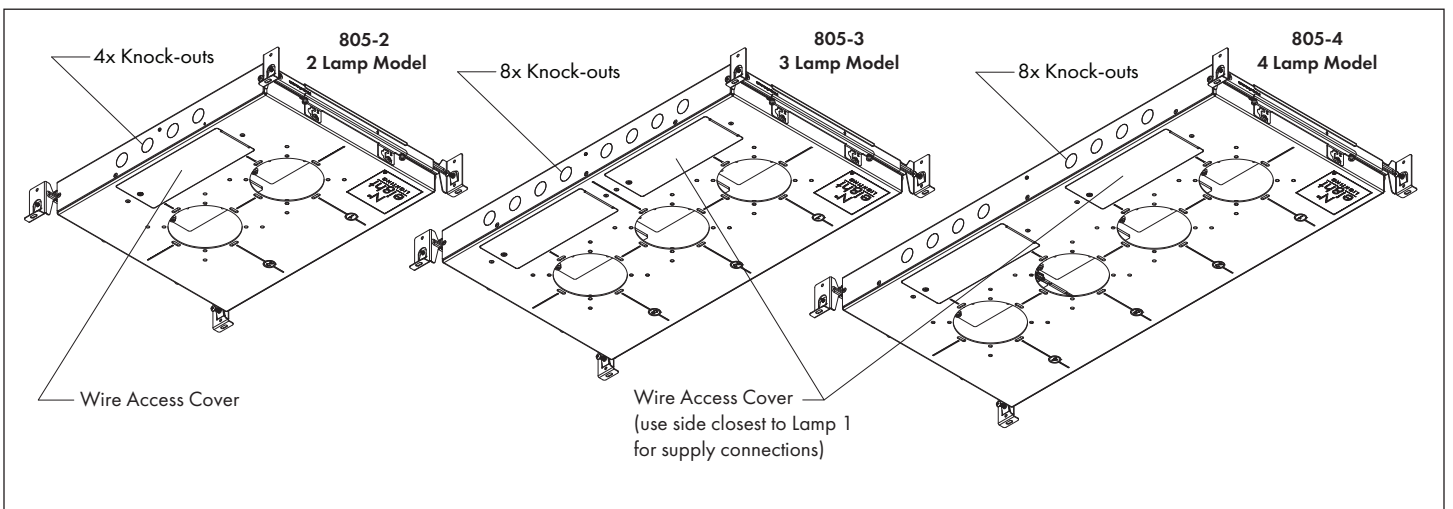
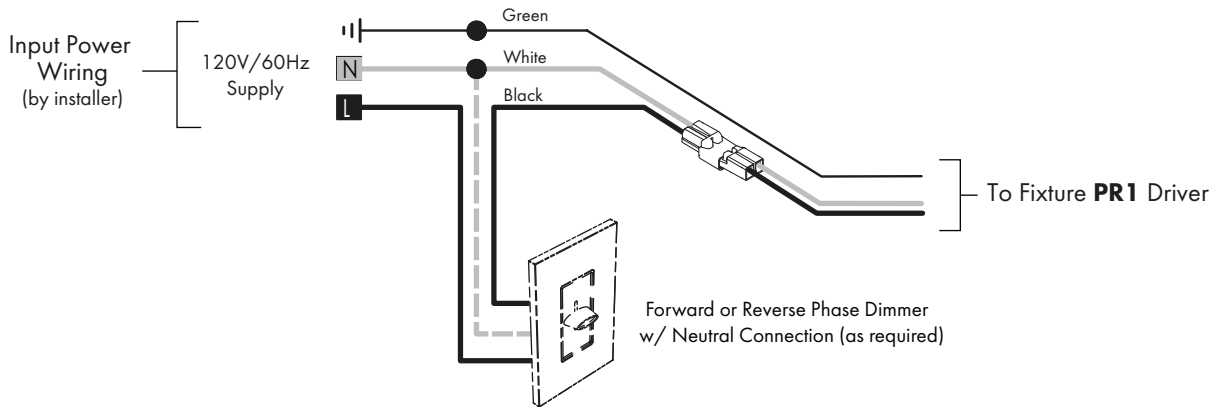

FIG 16.3 Wire Access - Multi-lamp Models

WIRING DIAGRAMS

PR1 - PHASE CONTROL



Phase Control Notes:

PR1 drivers are Forward or Reverse Phase dimmable.

For compatible dimmers for use with **PR1** drivers see: www.8lighting.com/resources-downloads

NOTE: For compatible dimmers for use with **PR1** drivers see www.8lighting.com/resources-downloads/

FIG 17.1 Wiring Diagram

EL1/EL1-01 - 0-10V CONTROL

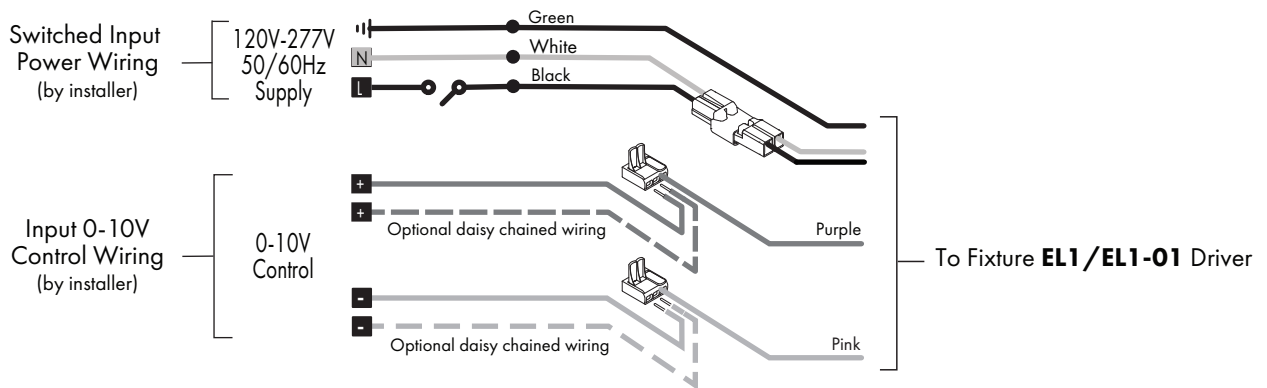

0-10V Control Notes:

0-10V control wiring is polarity sensitive and should be run as Class 2.

300' is the maximum control wiring run length to reduce EMI susceptibility and voltage drop. Voltage drop should be no greater than 0.3V.

For compatible dimmers for use with **EL1/EL1-01** drivers see: www.8lighting.com/resources-downloads .

FIG 17.2 Wiring Diagram

WIRING DIAGRAMS

EL2 / EL2-01 - DALI CONTROL

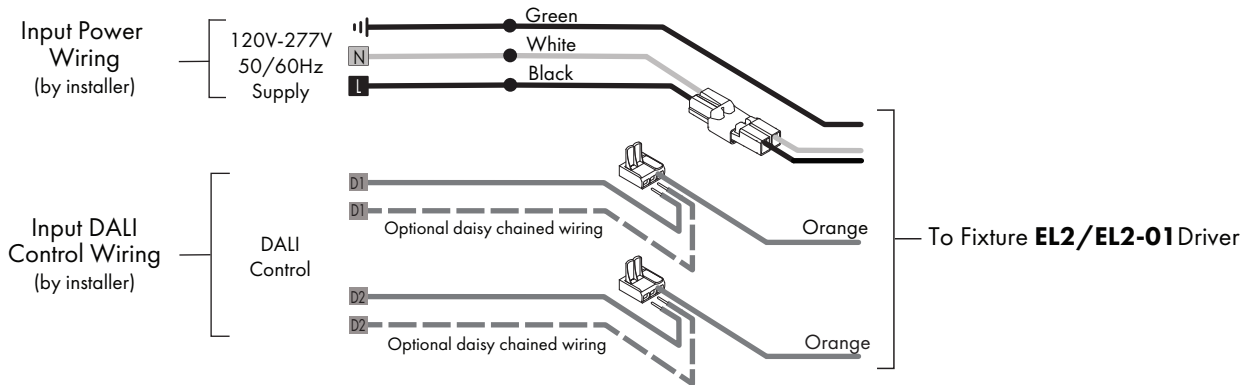

DALI Control Notes:

DALI control wiring is not polarity sensitive and can be run as Class 1 or 2. Up to 64 **EL2/EL2-01** drivers can be daisy chained per DALI control loop. Maximum control wiring run length is 1000'.

For compatible dimmers for use with **EL2/EL2-01** drivers see: www.8lighting.com/resources-downloads.

FIG 18.1 Wiring Diagram

LU4 - LUTRON ECOSYSTEM CONTROL

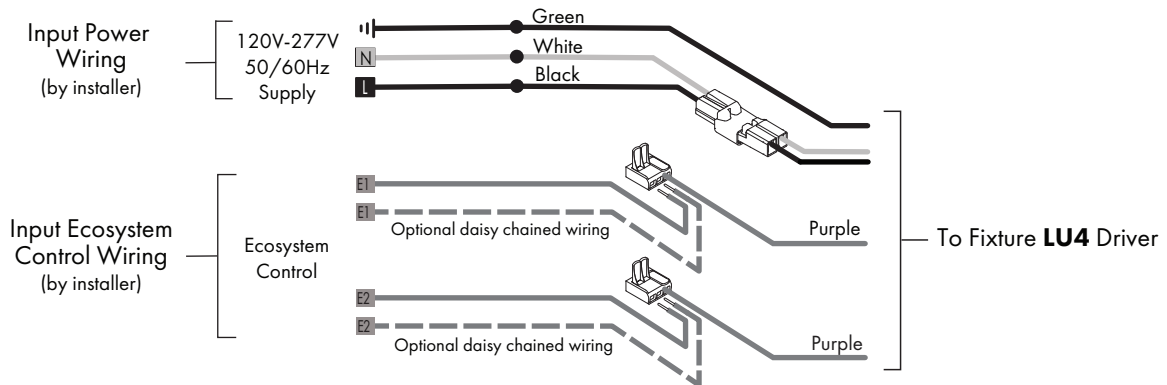

Lutron Ecosystem Control Notes:

Up to 64 **LU4** drivers can be daisy chained per Ecosystem control loop.

Maximum control wiring run length is 1000'.

For additional information, contact LED Center of Excellence at 1.877.346.5338 or LEDs@lutron.com

FIG 18.2 Wiring Diagram

WIRING DIAGRAMS - 2 CHANNEL TUNABLE WHITE

DAL2 - 2 CHANNEL DALI CONTROL

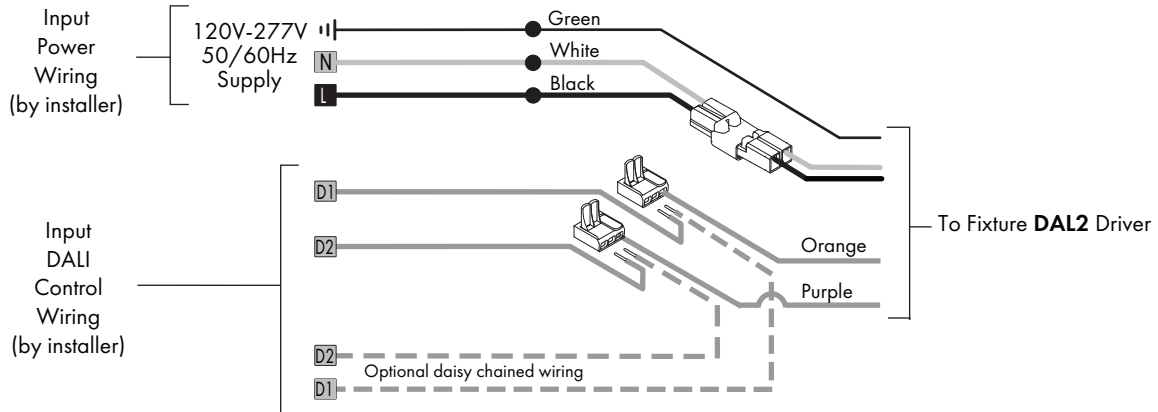

DALI Control Notes:

DALI control wiring is not polarity sensitive and can be run as Class 1 or 2. Each **DAL2** driver will be discovered with two incremented short addresses: one for CCT and one for INTENSITY. Up to 32 **DAL2** drivers can be daisy-chained per DALI control loop. Maximum control wiring run length is 1000'. For compatible dimmers for use with **DAL2** drivers see: www.8lighting.com/resources-downloads.

FIG 19.1 Wiring Diagram

DMX2 - 2 CHANNEL DMX CONTROL

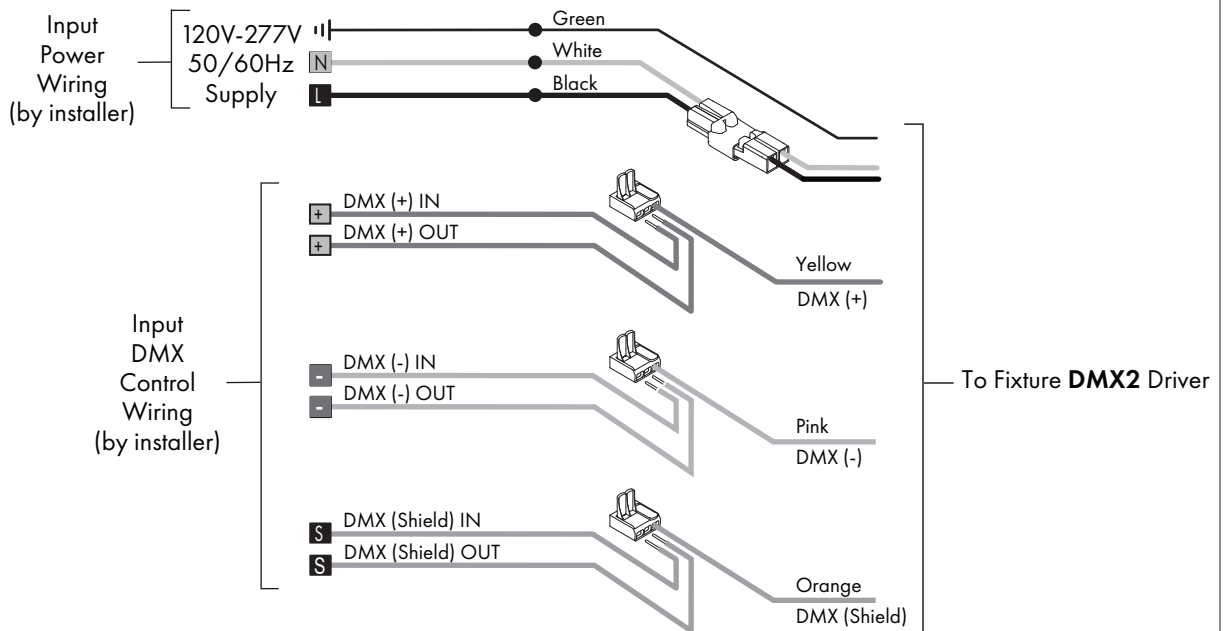

DMX Notes:

DMX control wiring is polarity sensitive and should be run as Class 2. Each **DMX2** driver is one "unit load". DMX runs without a repeater/signal booster should be limited to no more than 32 drivers including controller depending on the site conditions. **DMX2** drivers are RDM compatible and addressable by others in the field. Termination of the DMX runs is to be done by others per DMX512A specification. Maximum control wiring run length is 1000'. For compatible dimmers for use with **DMX2** drivers see: www.8lighting.com/resources-downloads.

FIG 19.2 Wiring Diagram

WIRING DIAGRAMS - 2 CHANNEL TUNABLE WHITE

DIM6 2 CHANNEL 0-10 CONTROL

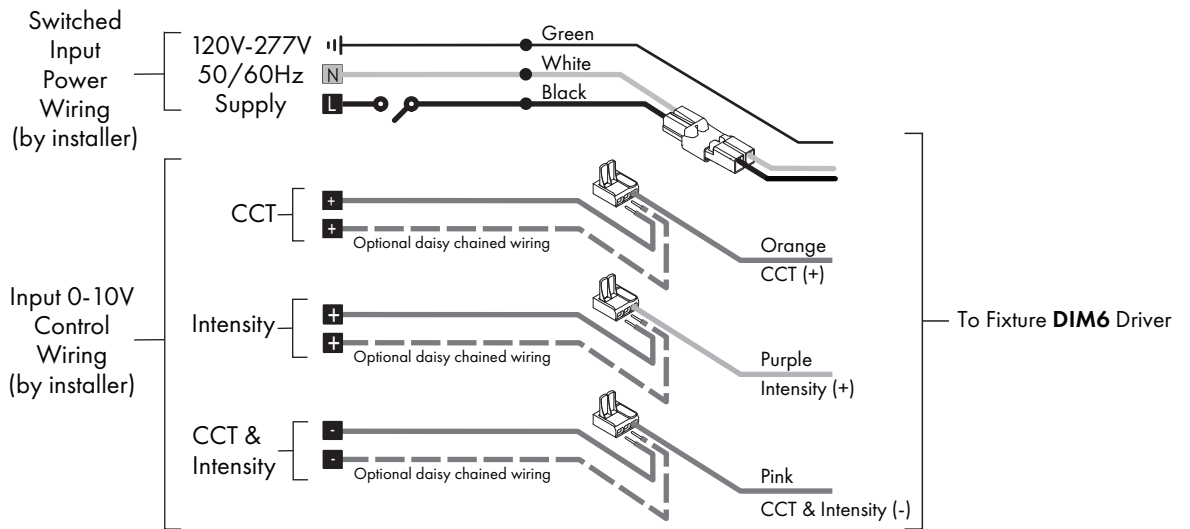

0-10V Control Notes:

0-10V control wiring is polarity sensitive and should be run as Class 2. Each **DIM6** driver requires two pairs of Class 2 control wires: one pair for CCT and one pair for INTENSITY. CCT and Intensity (-) input connections are shared. 300' is the maximum control wiring run length to reduce EMI susceptibility and voltage drop. Voltage drop should be no greater than 0.3V.
 For compatible dimmers for use with **DIM6** drivers see: www.8lighting.com/resources-downloads.

FIG 20.1 Wiring Diagram



www.8lighting.com

Number Eight Lighting Company

526 Portal Street, Cotati, CA 94931

Phone (707) 794-0888 • Email customerservice@8lighting.com