



200 SERIES
202/203 NEW CONSTRUCTION
INSTALLATION INSTRUCTIONS



SCAN QR CODE FOR INSTRUCTIONS

WARNING: Read and understand these instructions completely before installation. Disconnect power at circuit breaker or fuse panel before installation. Always allow LED assembly to cool before servicing. To be installed by qualified electricians only. Products should be installed in accordance with these instructions, local electrical codes, and the National Electric Code (NEC). These products may represent a possible shock or fire hazard if improperly installed.

Do not install where insulation or ambient temperatures will exceed maximum values noted in product specifications. See www.8lighting.com for current product specifications.



NOTE: Number Eight Lighting fixtures are designed to meet the latest NEC requirements and are listed in full compliance with UL standards. Before attempting installation check and understand your local electrical code which sets the wiring standards and installation requirements for your locality.

Save these instructions.





TABLE OF CONTENTS



| | PAGE |
|--|-------------|
| 200 SERIES COMPONENTS..... | 1-2 |
| NEW CONSTRUCTION INSTALLATION – FLANGED TRIMS w / SHEETROCK CEILINGS..... | 3-5 |
| NEW CONSTRUCTION INSTALLATION – FLANGELESS TRIMS w / SHEETROCK CEILINGS..... | 6-8 |
| NEW CONSTRUCTION INSTALLATION – FLANGELESS TRIMS w / WOOD/STONE CEILINGS...9-12 | |
| AIMING AND ADJUSTMENT and TRIM PLATE FINISHING and INSTALLATION..... | 13 |
| WIRING DIAGRAMS..... | 14-15 |



200 SERIES NEW CONSTRUCTION COMPONENTS

| | |
|---|--|
| 201 FIXED POSITION LIGHT ENGINE | 202 ADJUSTABLE LIGHT ENGINE |
|  <p>201-R/ 201-R-BV</p> <p>201-S/ 201-S-BV</p> |  <p>202-R/ 202-R-BV</p> <p>202-S/ 202-S-BV</p> |

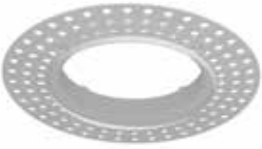
| | | |
|---|---|--|
| 203 WALL WASH LIGHT ENGINE | WALL WASH TRIM PLATES (for 203-R/S Light Engines) | |
|  <p>203-R</p> <p>203-S</p> |  <p>FLR-2-WW</p> |  <p>FLS-2-WW</p> |

| | | | |
|---|---|---|--|
| FLAT TRIM PLATES (for 201-R/S and 202-R/S Light Engines) | | BEVEL TRIM PLATES (for 201-R/S and 202-R/S Light Engines) | |
|  <p>FLR-2</p> |  <p>FLS-2</p> |  <p>FLR-2-BV</p> |  <p>FLS-2-BV</p> |

| | | |
|--|---|---|
| FLANGELESS TRIM MOUNTING ACCESSORIES for SHEETROCK CEILING APPLICATIONS | | |
|  <p>FR-2 FLANGELESS trim accessory for flush mounting ROUND trims in SHEETROCK</p> |  <p>FS-2 FLANGELESS trim accessory for flush mounting SQUARE trims in SHEETROCK</p> | <p>Note: FR-2 and FS-2 flangeless trim accessories for use with NIC-FR/FS and IC-CP-FR/FS mounting frames.</p> |

| | | |
|---|---|--|
| OPTIC OPTIONS + ACCESSORIES | | |
| <p>TIR-15 15° Narrow spot</p> <p>TIR-25 25° Narrow flood</p> <p>TIR-40 40° Flood</p> <p>TIR-60 60° Wide flood</p> |  | <p>NSP Narrow softening lens</p> <p>NFL Medium softening lens</p> <p>FL Wide softening lens</p> <p>WFL Extra wide softening lens</p> <p>LS Linear spread Lens</p>  |

200 SERIES NEW CONSTRUCTION COMPONENTS

| NIC MOUNTING FRAMES - Type Non-IC Rated | | IC-CP MOUNTING FRAMES - Type IC/CP Rated | |
|--|--|--|--|
| For FLANGED Trims | | For FLANGED Trims | |
|  <p style="text-align: center;">NIC-R NIC-S</p> | |  <p style="text-align: center;">IC-CP-R IC-CP-S</p> | |
| For FLANGELESS TRIMS with SHEETROCK CEILINGS | | For FLANGELESS TRIMS with SHEETROCK CEILINGS | |
|  <p style="text-align: center;">NIC-FR NIC-FS (requires FR-2 accessory) (requires FS-2 accessory)</p> | |  <p style="text-align: center;">IC-CP-FR IC-CP-FS (requires FR-2 accessory) (requires FS-2 accessory)</p> | |
| For FLANGELESS TRIMS with WOOD/STONE CEILINGS | | For FLANGELESS TRIMS with WOOD/STONE CEILINGS | |
|  <p style="text-align: center;">NIC-FR-W NIC-FS-W</p> | |  <p style="text-align: center;">IC-CP-FR-W IC-CP-FS-W</p> | |
| <p>Note: Use NIC Mounting frames for TYPE NON-IC installations where insulation is held back a minimum of 3" from sides and top.</p> <p>CAUTION: Ambient temperatures in ceiling space should not exceed 40°C (104°F) during normal operation.</p> | | <p>Note: Use IC-CP Mounting frames for TYPE IC installations in direct contact with thermal insulation (standard or spray-foam) with a max R-value of R-42 or for CCEA (Chicago Plenum) installations.</p> <p>CAUTION: When installed in contact with thermal insulation, ambient temperatures in ceiling space should not exceed 25°C (77°F) during normal operation. For installations where insulation is held back a minimum of 3" from sides and top, ambient temperatures in ceiling space should not exceed 40°C (104°F) during normal operation.</p> | |
| FRAME MOUNTING ACCESSORIES | | | |
|  <p>BB BUTTERFLY BRACKET (Set of 2) For commercial c-channel or bar mounting</p> | |  <p>BH BAR HANGER (Set of 2) For joist mounting</p> | |
|  <p>PMB PANEL MOUNTING BRACKET (Set of 2) For direct mounting to wood panels</p> | |  <p>TBC T-BAR MOUNTING CLIPS (Set of 4) For use with BH Bar Hanger in T-GRID ceiling applications</p> | |

NEW CONSTRUCTION INSTALLATION

STEP 1 - MOUNTING FRAME ASSEMBLY AND INSTALLATION

BH - BAR HANGER MOUNTING OPTION

1a. Attach bar hangers to either ends or sides of mounting frame using hole position 1

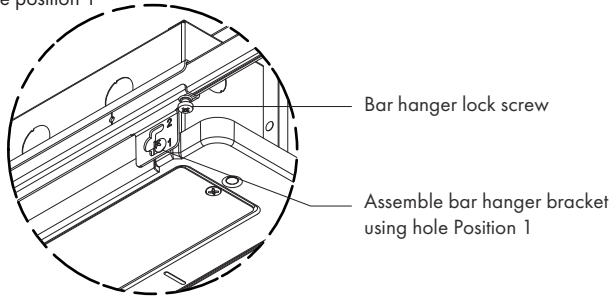

1b. Attach mounting frame to joists

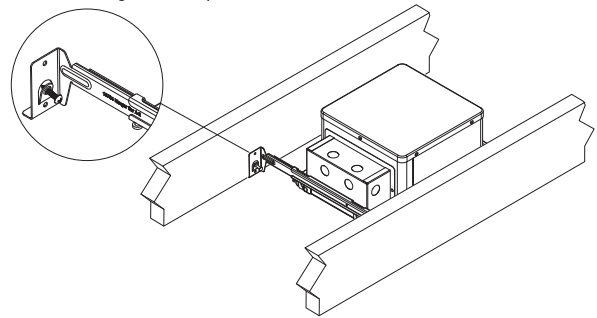

BB - BUTTERFLY BRACKET MOUNTING OPTION

1a. Attach butterfly brackets to either ends or sides of mounting frame

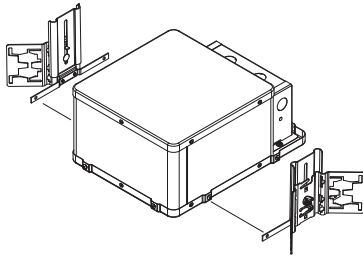

1b. Attach supports to bracket and adjust height with thumbscrew

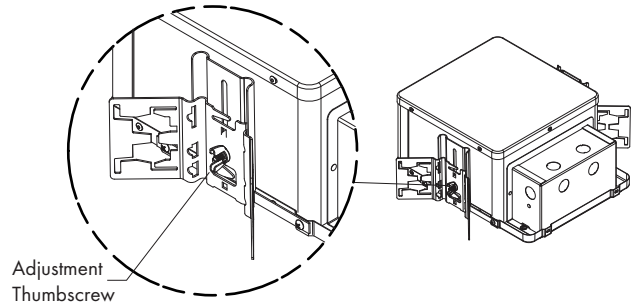

TBC-BH - T-BAR CLIP + BAR HANGER MOUNTING OPTION

1a. Assemble bar hangers as shown above and attach T-BAR mounting clips

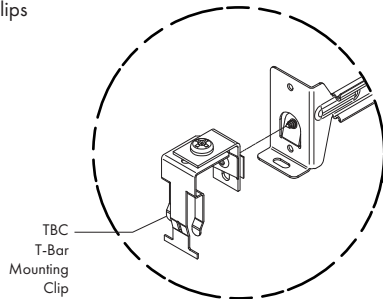

1b. Attach T-BAR clips to T-BARS

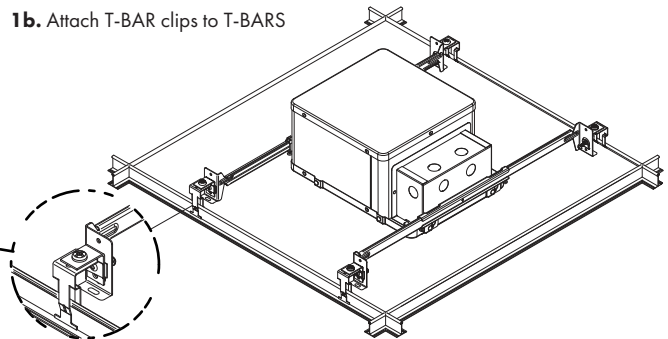

PMB - PANEL MOUNTING BRACKET OPTION

1a. Attach panel mount brackets to either ends or sides of mounting frame.

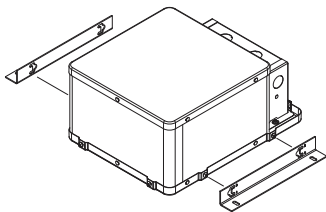

1b. Attach panel mount brackets to panel using hole position 1.

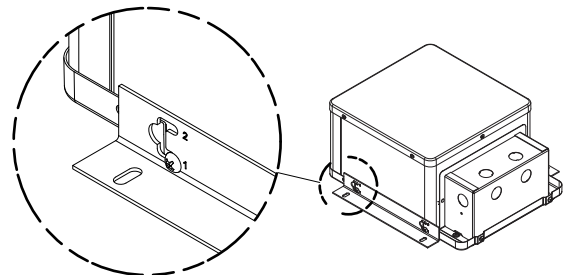

NEW CONSTRUCTION INSTALLATION - FLANGED TRIMS with SHEETROCK, WOOD STONE & ACCOUSTIC TILE CEILINGS

NIC-S and IC-CP-S MOUNTING FRAMES

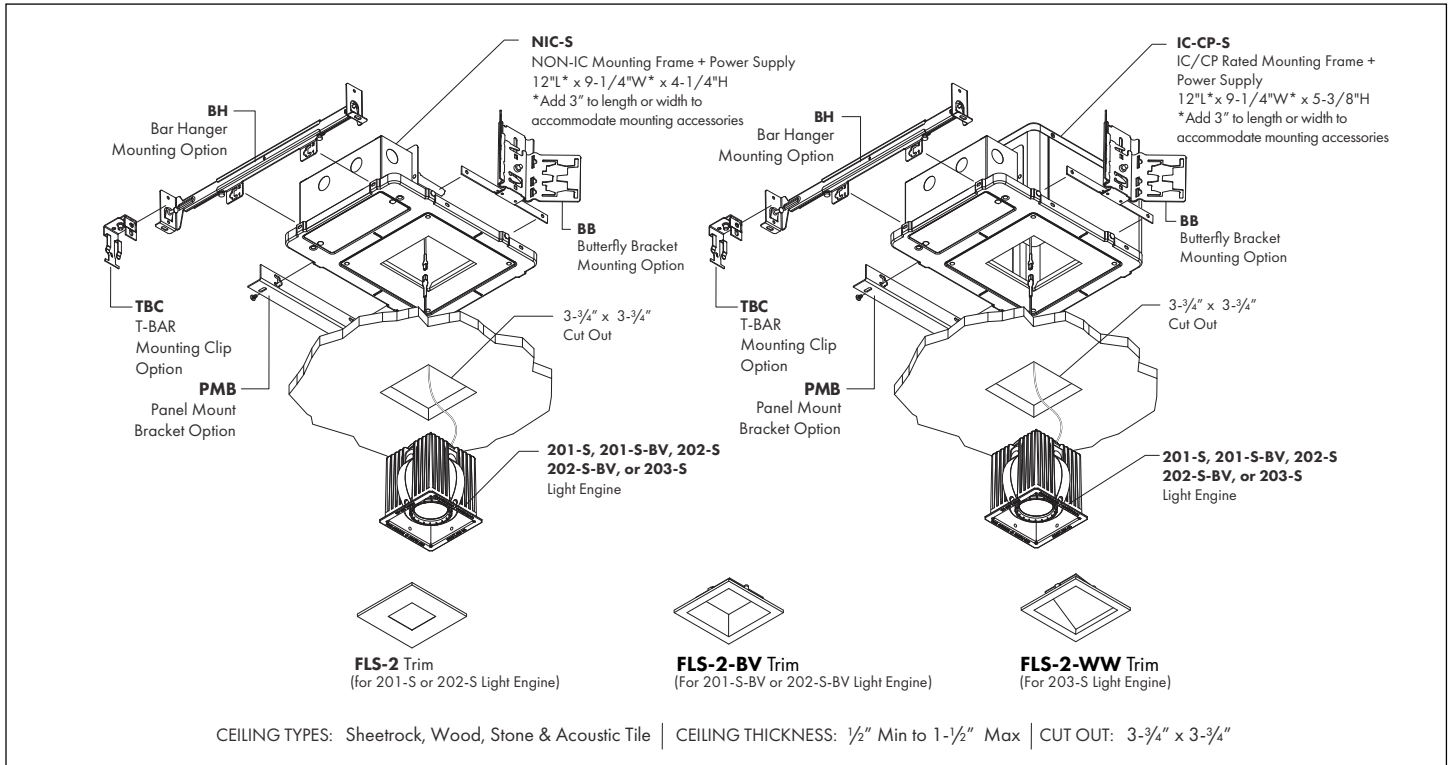

NIC-R and IC-CP-R MOUNTING FRAMES

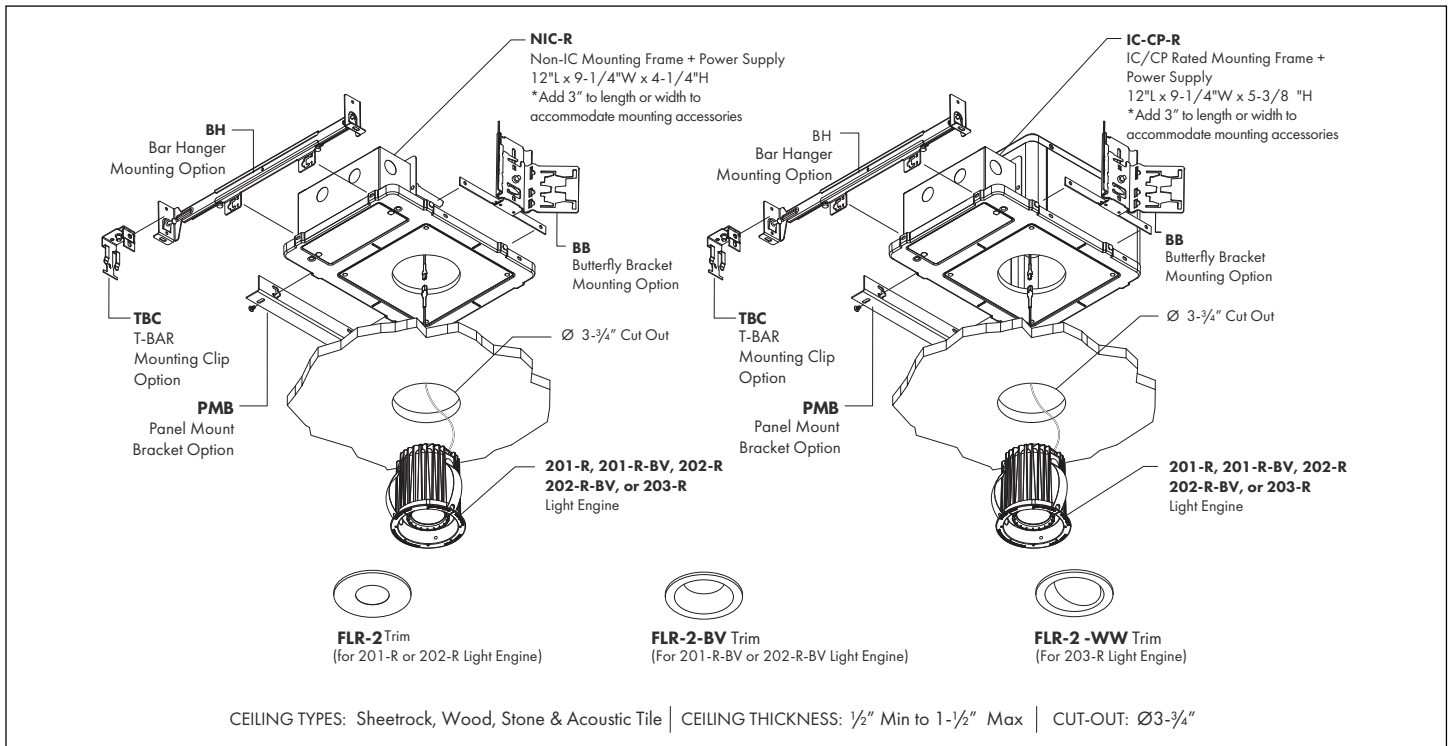

STEP 1 - REFER TO PAGE 3 for MOUNTING FRAME ASSEMBLY AND INSTALLATION

NEW CONSTRUCTION INSTALLATION - FLANGED TRIMS with SHEETROCK CEILINGS

STEP 2 – FIXTURE WIRING

- 2a.** Disconnect power at circuit breaker.
 - 2b.** Remove junction box cover. Install appropriate conduit connector(s) using one or more of the provided junction box knock-outs.
 - 2c.** Review wiring diagrams on pages 14 and 15, wire fixture accordingly. Place all wiring and connectors back in junction box and replace cover.
- Note:** 0-10v, DALI, or Lutron EcoSystem power supplies (if specified) require additional dimming control wiring

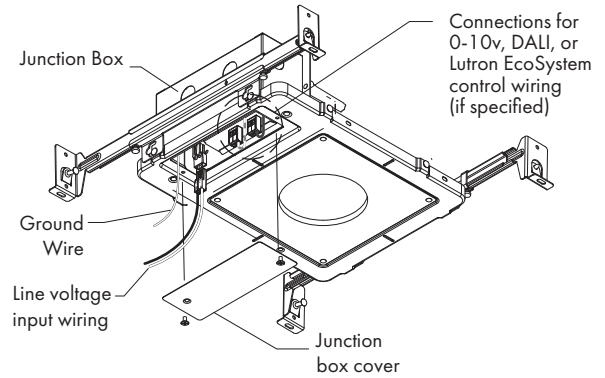

STEP 3 – CEILING CUT-OUT

- 3a.** Install ceiling material over mounting frame noting approximate location of frame aperture. Using a spiral saw with appropriate guide bit, make square or round cut-out for the light engine using mounting frame aperture plate as guide. **Note:** Use caution to avoid damaging power supply wire lead.

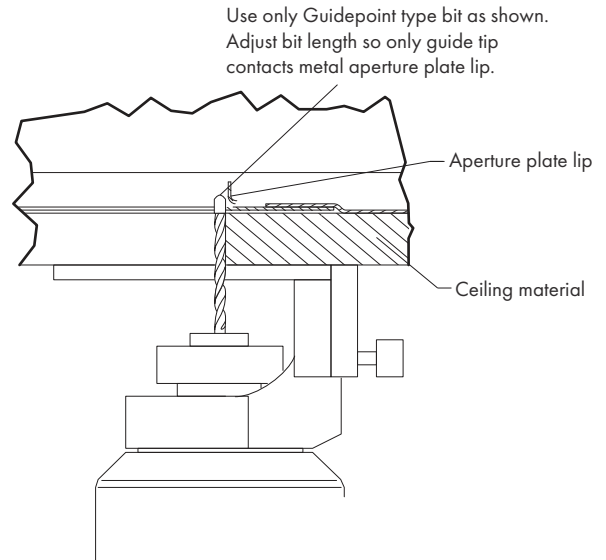
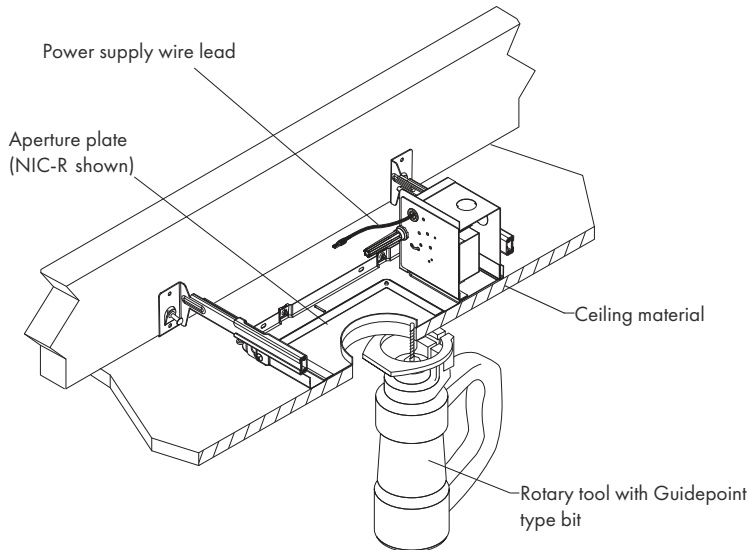

STEP 4 – LIGHT ENGINE WIRING AND INSTALLATION

- 4a.** Connect light engine wire lead to power supply wire lead.

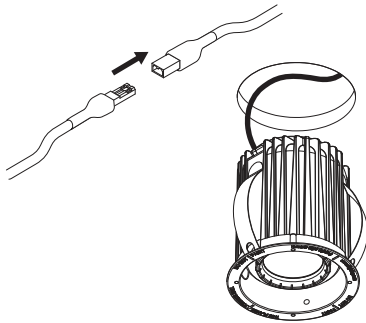

- 4b.** Rotate light engine so arrow shown on flange is perpendicular with adjacent wall.

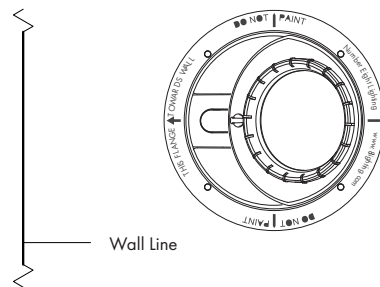

- 4c.** Install light engine through cut-out and into mounting frame.

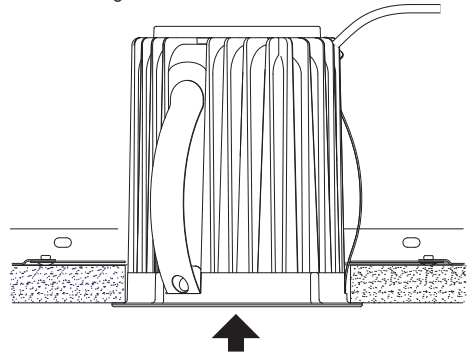

- 4d.** Install trim plate (see Page 13).

NEW CONSTRUCTION INSTALLATION - FLANGELESS TRIMS with SHEETROCK CEILINGS

NIC-FS and IC-CP-FS MOUNTING FRAMES

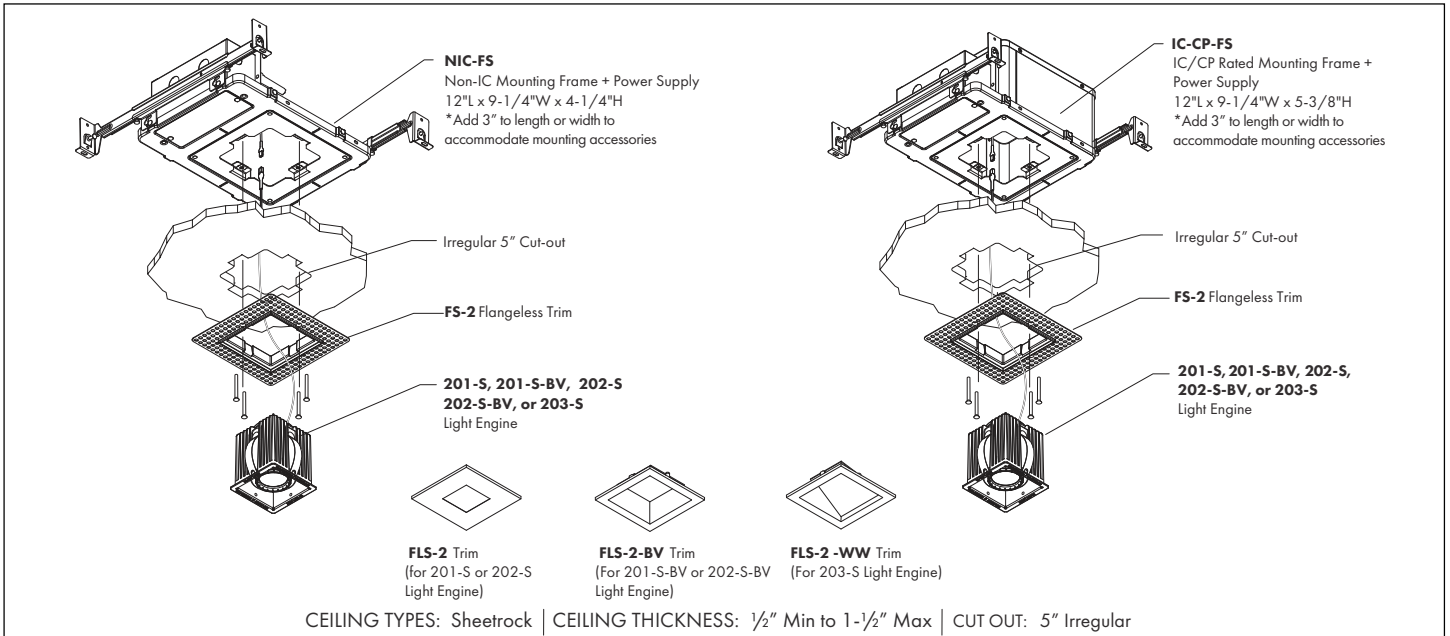

NIC-FR and IC-CP-FR MOUNTING FRAMES

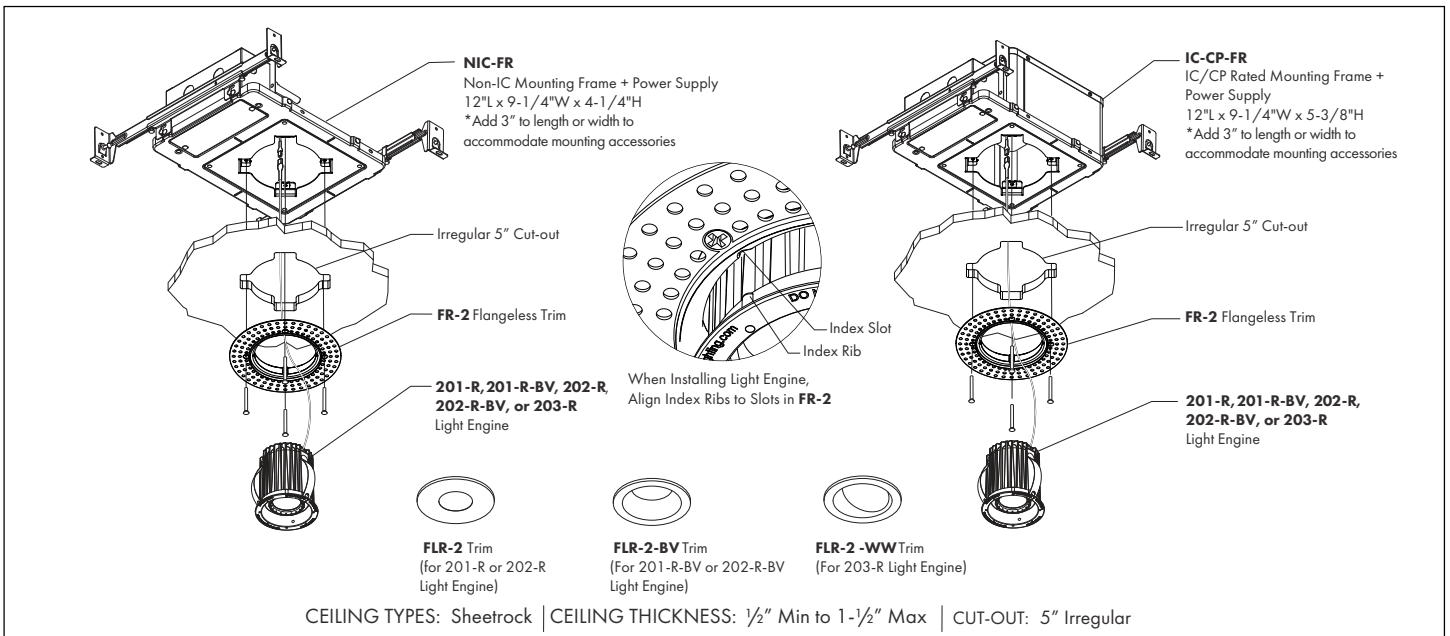

STEP 1 – REFER TO PAGE 3 FOR MOUNTING FRAME ASSEMBLY AND INSTALLATION

NEW CONSTRUCTION INSTALLATION - FLANGELESS TRIMS with SHEETROCK CEILINGS

STEP 2 – FIXTURE WIRING

- 2a.** Disconnect power at circuit breaker.
- 2b.** Remove junction box cover. Install appropriate conduit connector(s) using one or more of the provided junction box knock-outs.
- 2c.** Review wiring diagrams on pages 14 & 15, wire fixture accordingly. Place all wiring and connectors back in junction box and replace cover.

Note: 0-10v, DALI, or Lutron EcoSystem power supplies (if specified) require additional dimming control wiring

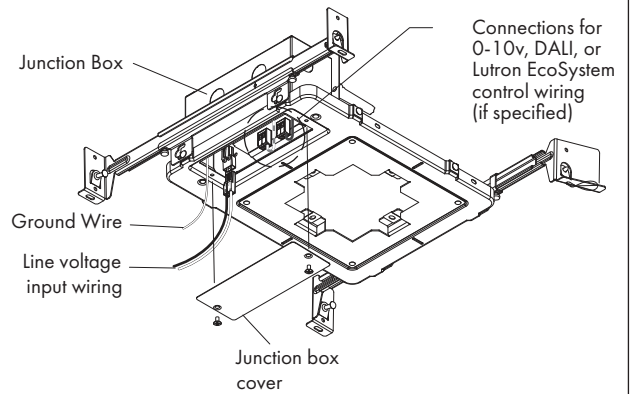

STEP 3 – CEILING CUT-OUT

- 3a.** Install ceiling material over mounting frame noting approximate location of frame aperture. Using a spiral saw with appropriate guide bit, make square or round cut-out for the light engine using mounting frame aperture plate as guide.

Note: Use caution to avoid damaging power

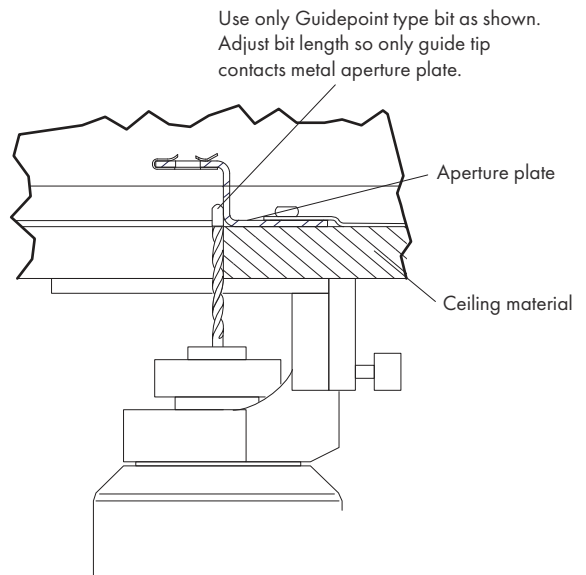
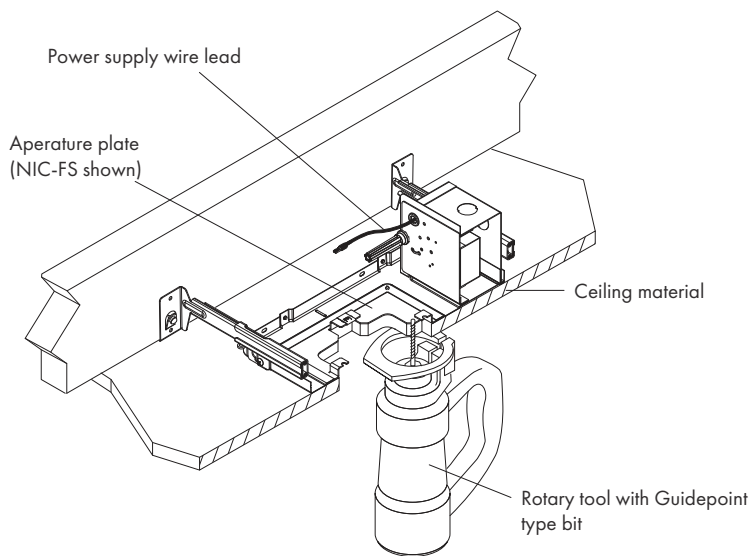

STEP 4 – FLANGELESS TRIM INSTALLATION

- 4a.** Remove mud shield and save. Install FS-2 or FR-2 flangeless trim to mounting frame through cut-out using 4x FHMS 8-32 screws provided.

Note: do not tighten screws until Step 4b.

- 4b.** Rotate trim to be aligned with adjacent walls or fixtures as shown below. Note: hand tighten trim screws. Power driver is not recommended.

FR-2 FLANGELESS TRIM

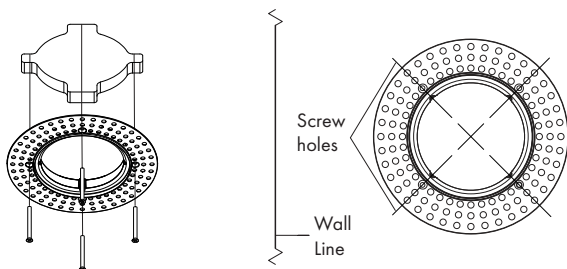

FS-2 FLANGELESS TRIM

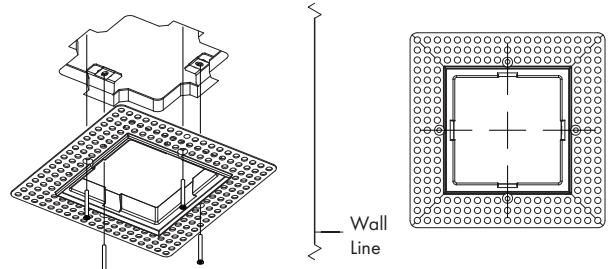

NEW CONSTRUCTION INSTALLATION - FLANGELESS TRIMS with SHEETROCK CEILINGS

STEP 4 – FLANGELESS TRIM INSTALLATION (CONTINUED)

4c. Reinstall mud shield

4d. Apply 6" wide fiberglass mesh tape over perforated metal trim flange leaving 1/8" cut-out around the outside edge of the raised trim lip and extending over sheetrock.

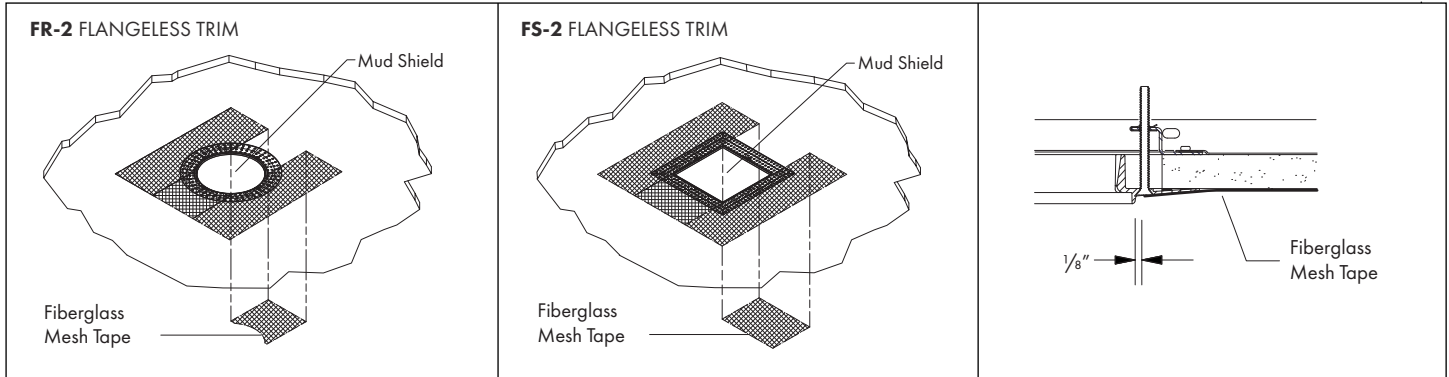

4e. Apply ceiling finish around FR-2 or FS-2 flangeless trim. Note: Minimum Level 4 or 5 finish is recommended.

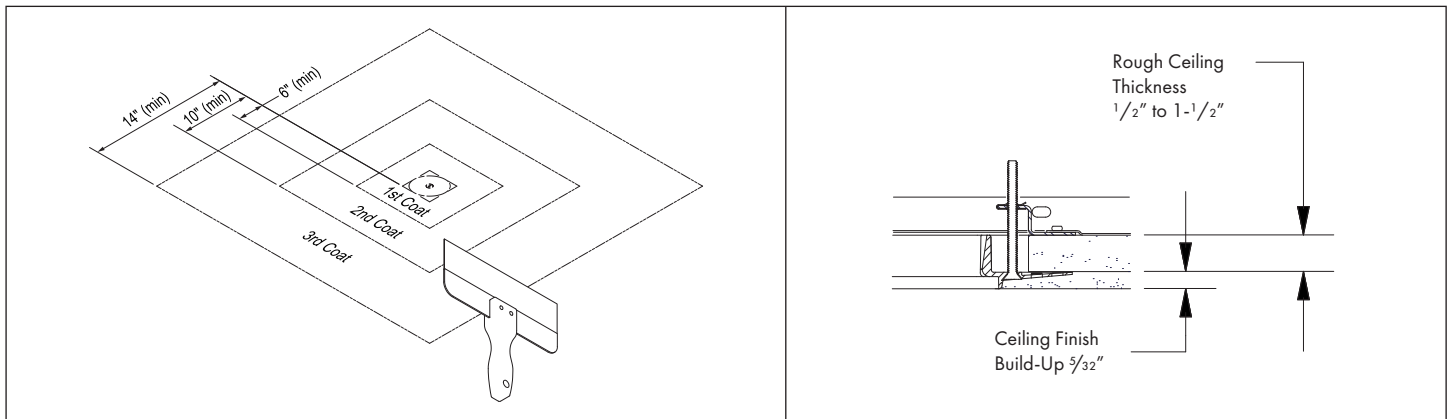

4f. First Coat - Apply USG "Durabond" setting-type joint compound for embedding the perforated flange and fiberglass mesh tape following the manufacturer's instructions and warnings for outside corners and trim. The compound should extend a minimum of 6" from the trim edge. Allow first coat to dry completely and remove any high spots by lightly sanding before applying the second coat.

4g. Second Coat - Apply USG general purpose ready-mixed joint compound flush to finished edge of trim, floating outward following the manufacturer's instructions and warnings. The compound should extend a minimum of 10" from the trim edge. Allow second coat to dry completely and remove any high spots by lighting sanding before applying the third coat.

4h. Third Coat - Apply USG ready-mixed finishing joint compound flush to finished edge of trim, floating outward following the manufacturer's instructions and warnings. The compound should extend a minimum of 14" from the trim edge. Allow third coat to dry completely before sanding.

4i. Sand third coat with fine grit sandpaper until mud shield and finished metal edge of trim lip are barely exposed.

4j. Remove mud shield.

4k. Remove excess material from inside edges of trim.

4l. Apply primer (USG Sheetrock or equivalent) and paint following the paint manufacturer's instructions and warnings.

CAUTION: Do not paint inside of FR-2 OR FS-2 trim surface.

STEP 5 – LIGHT ENGINE WIRING AND INSTALLATION

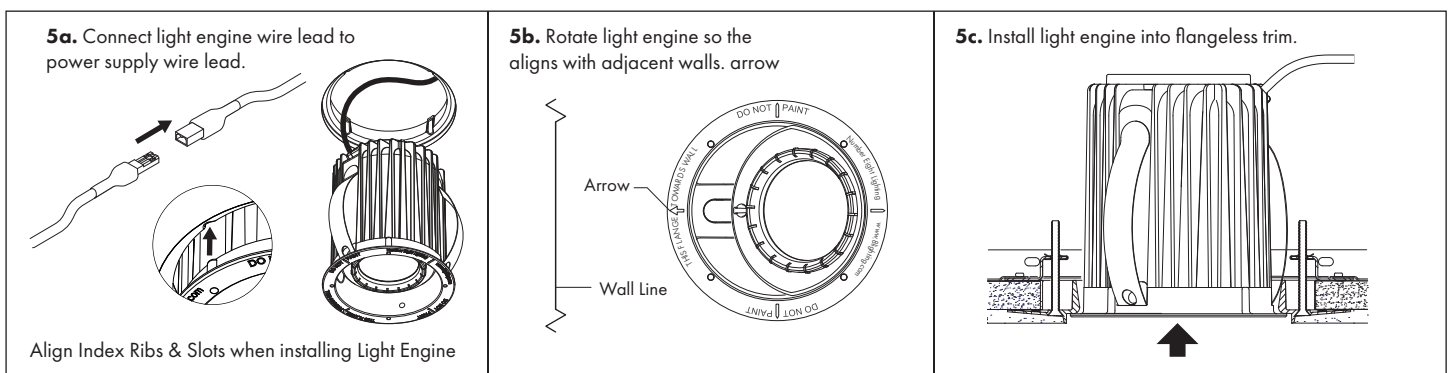

5d. Install trim plate (see Page 13).

NEW CONSTRUCTION INSTALLATION - FLANGELESS TRIMS with WOOD/STONE CEILINGS

NIC-FS-W and IC-CP-FS-W MOUNTING FRAMES

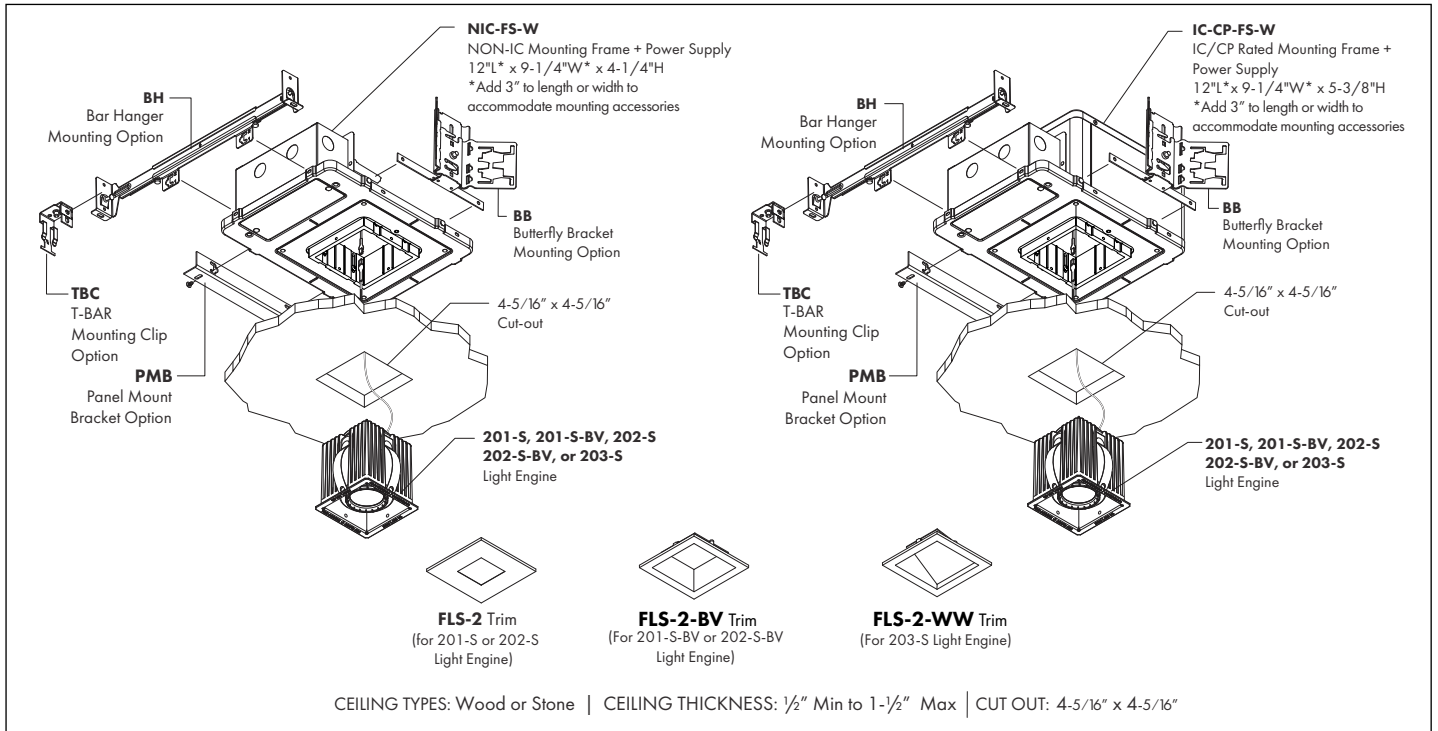

NIC-FR-W and IC-CP-FR-W MOUNTING FRAMES

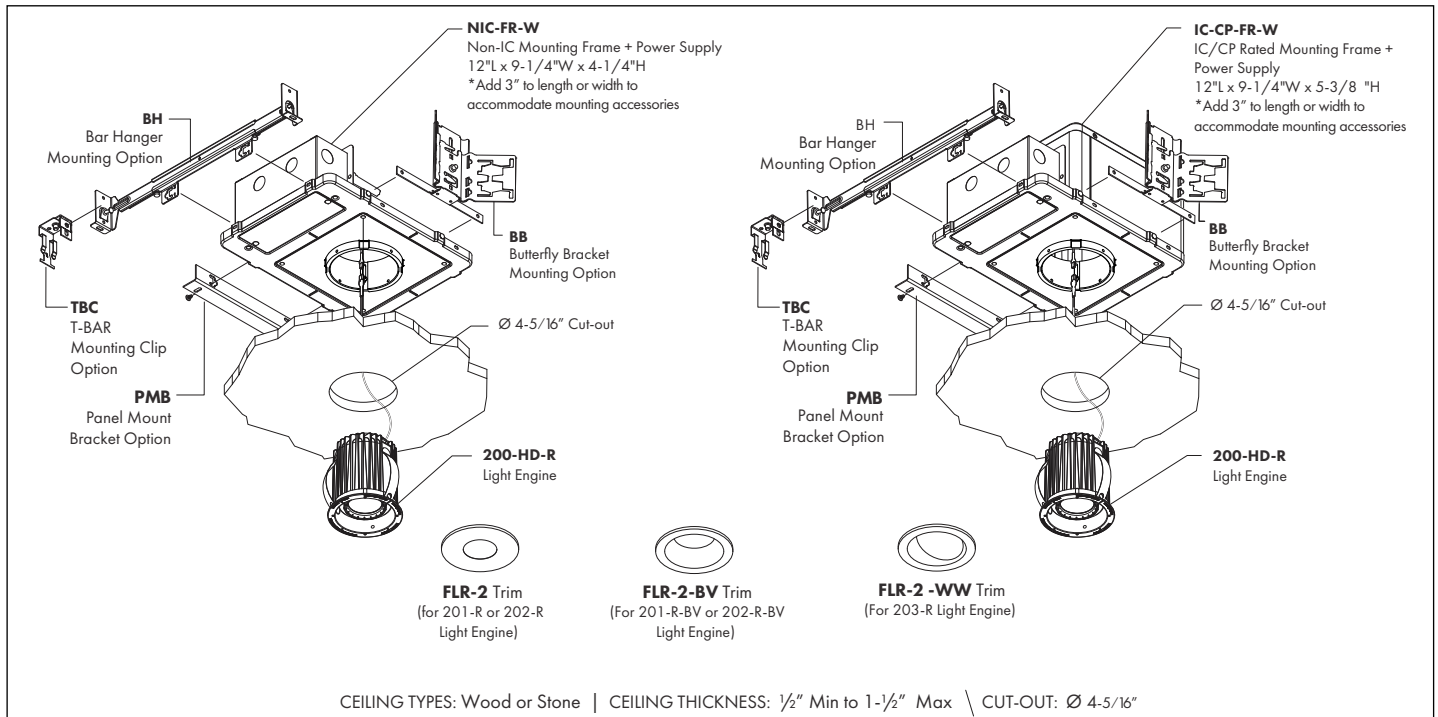

STEP 1 - REFER TO PAGE 3 FOR MOUNTING FRAME ASSEMBLY AND INSTALLATION

NEW CONSTRUCTION INSTALLATION - FLANGELESS TRIMS with WOOD/STONE CEILINGS

STEP 2 – FIXTURE WIRING

- 2a.** Disconnect power at circuit breaker.
- 2b.** Remove junction box cover. Install appropriate conduit connector(s) using one or more of the provided junction box knock-outs.
- 2c.** Review wiring diagrams on **Pages 14 and 15**, wire fixture accordingly.
Place all wiring and connectors back in junction box and replace cover.

Note: 0-10v, DALI, or Lutron EcoSystem power supplies (if specified) require additional dimming control wiring.

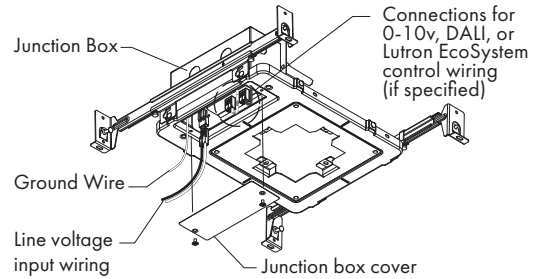

STEP 3 (OPTIONAL) – SQUARE COLLAR ANGLE ADJUSTMENT

Note: The Square Collar can be rotated +/- 5° to align with adjacent wall or fixtures. Thumb Knobs shown below will permit adjustment.

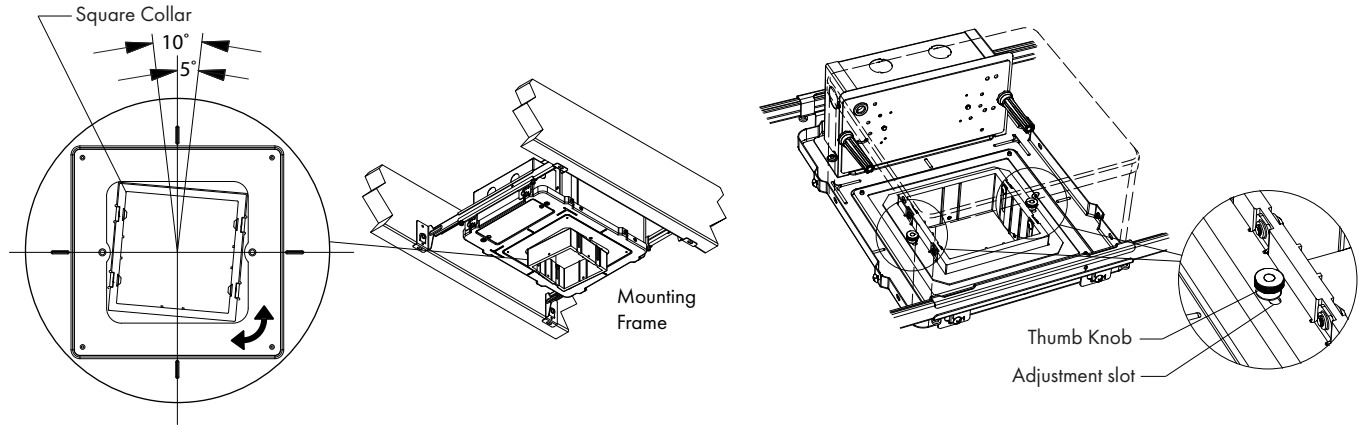

- 3a.** Loosen (do not remove) the 4x Collar Screws using supplied 5/32" allen key & pull the Square Collar down to the lowest position.
Note that the Collar Screws do not need to be fully tightened again until after determining final height adjustment for the Square Collar (see page 12).



- 3b.** Loosen two Thumb Knobs inside the Mounting Frame adjust the angle as needed.
Note: For open NIC Mounting Frames the two knobs may be accessible from above or the sides. For IC-CP mounting frames the knobs can only be accessed through the square collar.
- 3c.** Hand tighten the Thumb Knobs to lock-in the desired angle.

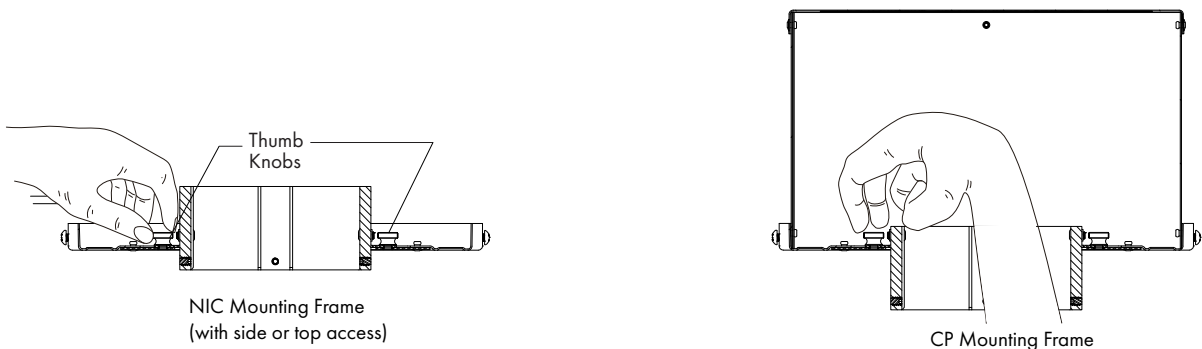

NEW CONSTRUCTION INSTALLATION - FLANGELESS TRIMS with WOOD/STONE CEILINGS

STEP 4 – CEILING CUT-OUT

4a. Ceiling cut-out must be precisely located & oriented to Square or Round collar location. All dimensions are +/- 1/32".

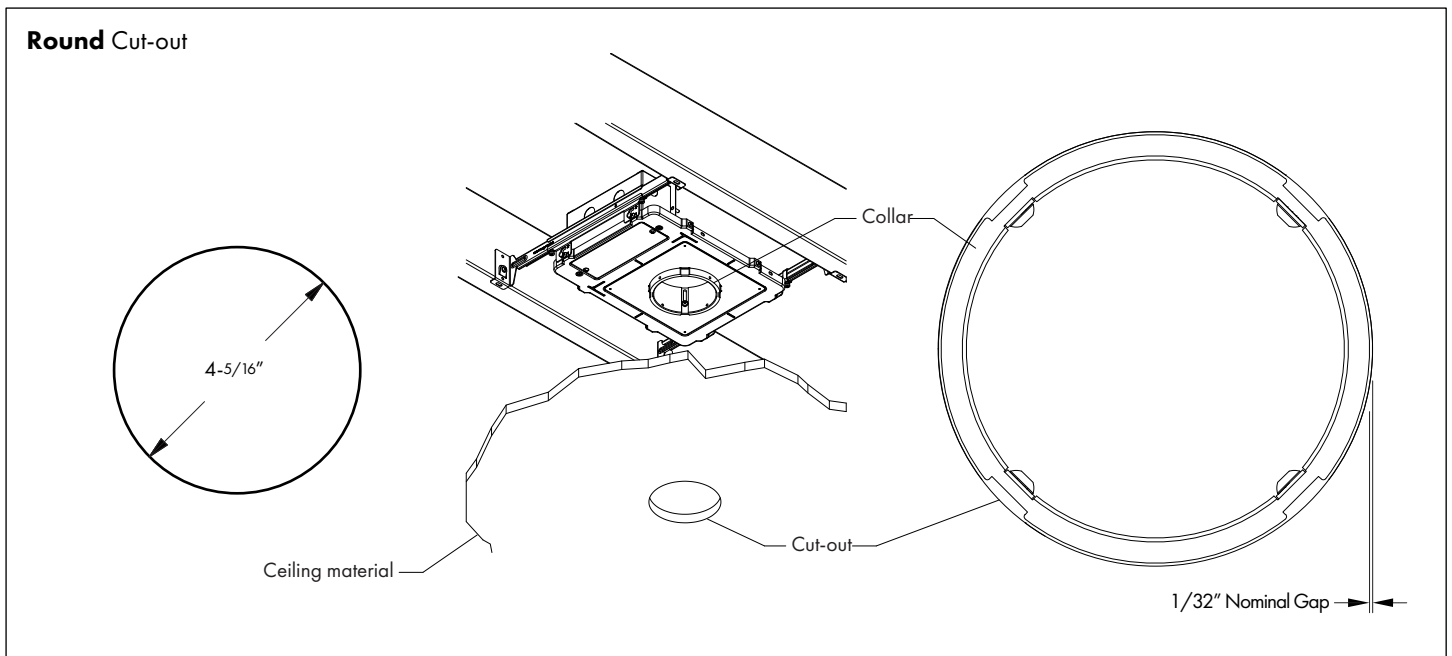
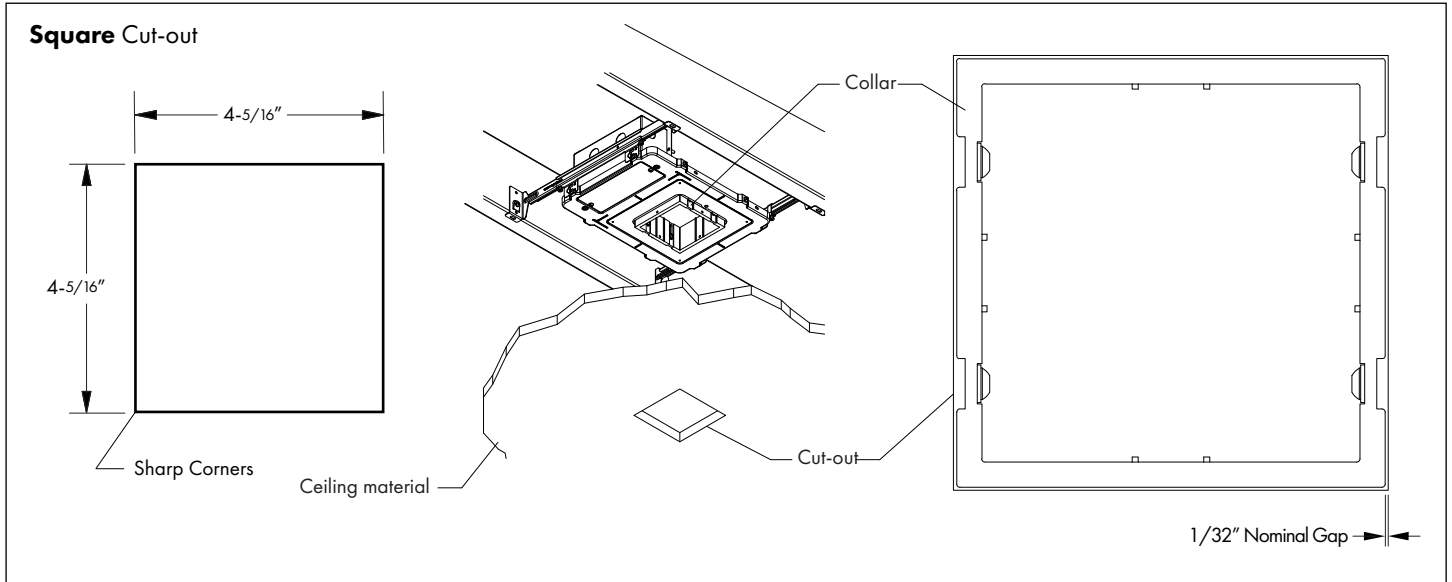

NEW CONSTRUCTION INSTALLATION - FLANGELESS TRIMS with WOOD/STONE CEILINGS

STEP 5 – FLANGELESS TRIM COLLAR ADJUSTMENT

CAUTION: Accurate Collar depth is required to install trim plate flush to surface. To ensure trim plate will be flush to the mounting surface, the collar must be recessed up into the mounting surface by the depth of the supplied trim plate gauge tip. Use tip marked **◀200**.

5a. Loosen the collar screws and check depth of collar at each set screw location using the trim plate gauge.

5b. Confirm depth using gauge. Once depth is corrected at each location, tighten the set screws to lock in the collar depth. (**DO NOT OVERTIGHTEN!**)

5c. Tighten 4x collar screws.

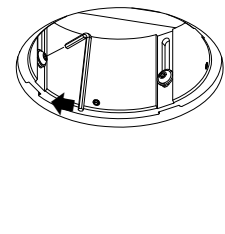
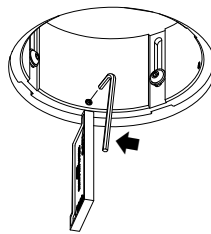
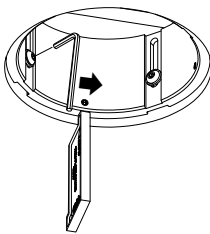
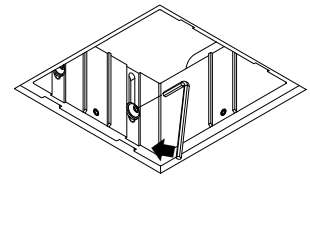
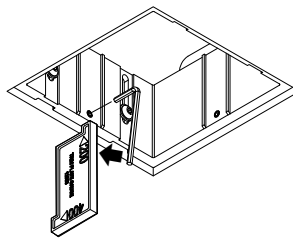
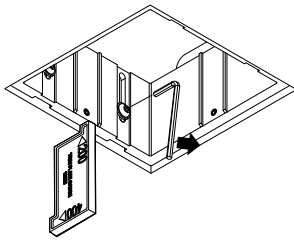
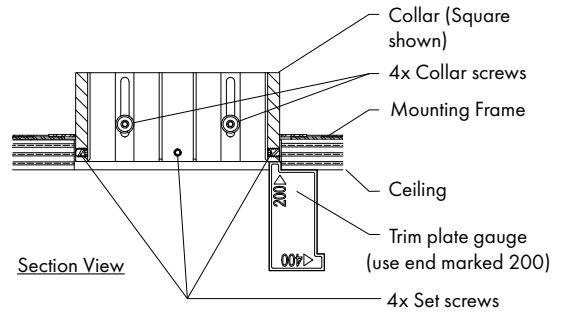

Fig 5a. Loosen Collar Screws, check & adjust Collar depth

Fig 5b. Confirm depth and tighten Set Screws. **DO NOT OVERTIGHTEN.**

Fig 5c. Tighten Collar Screws

STEP 6 – Light Engine Installation

6a. Connect light engine wire lead to power supply wire lead.

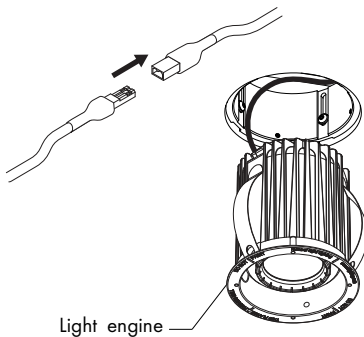

Light engine

6b. Orient light engine so arrow shown on flange will be perpendicular with adjacent wall.

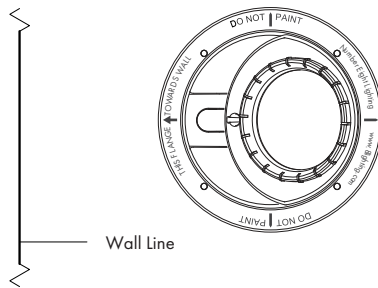

Wall Line

6c. Install light engine through cut-out and collar with light engine flush up against collar. Tighten set screws to lock in position.

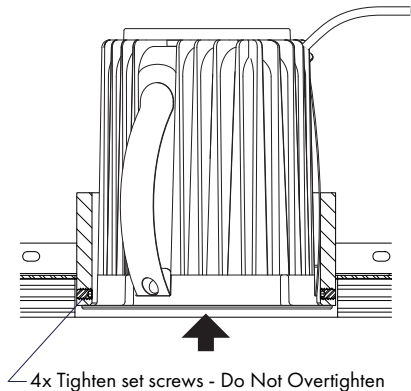

6d. Install trim plate (see page 13).

AIMING & ADJUSTMENT

STEP 1 - VERTICAL AND HORIZONTAL AIMING AND ADJUSTMENT (Adjustable light engine models 202-R/S or 202-R/S-BV only)

- 1b. Adjust vertical aiming by sliding the lamp holder to desired angle (0-30°)
- 1a. Adjust the horizontal aiming by rotating the lamp holder & housing to desired angle (0-360°)

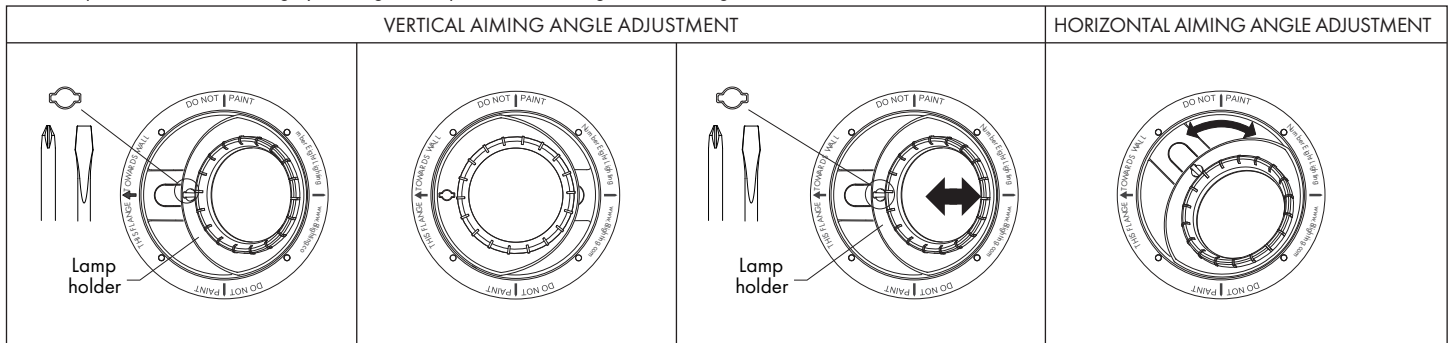

STEP 2 - LENS AND ACCESSORY REMOVAL AND REPLACEMENT

- 2a. Remove the lens ring from the lamp holder by unscrewing counter-clockwise.
- 2b. Remove optic lens (and accessory lens if used) by gently pressing upward on the center while holding the lens ring.
- 2c. Install desired optic (and accessory lens if used) by aligning the optic lens in lens ring.
- 2d. Reinstall lens ring on to lamp holder by turning clockwise.

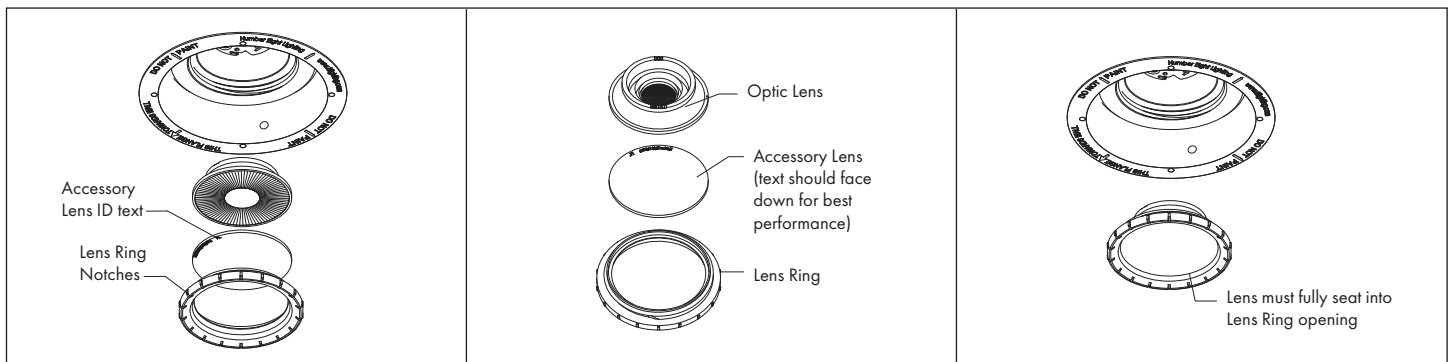

TRIM PLATE FINISHING & INSTALLATION

STEP 1. (OPTIONAL) - PAINT TRIM PLATE

- 1a. Remove the trim plate from packaging.
 - 1b. Clean and prepare exposed surfaces for painting following the paint manufacturers instructions and warnings.
 - 1c. Paint as desired using a "dry roller" or light spray application.
- Note:** If applying paint by spray method, mask trim plate lens (If installed).
- CAUTION:** Paint must be rated for minimum 90 C (150 F). Do not paint trim plate while installed in fixture. Do not paint backside of trim plate or safety cable.
- Do not** paint edges of trim plate if using with **FR-2** or **FS-2** flangeless trim.
- 1d. Allow trim plate to dry completely before installing.

STEP 2 – INSTALL TRIM PLATE

- 2a. Loosen set screw in trim plate to accept safety cable.
- 2b. Extend trim safety cable out of housing and insert ferrule at end of the cable under set screw from side and secure with hex key.

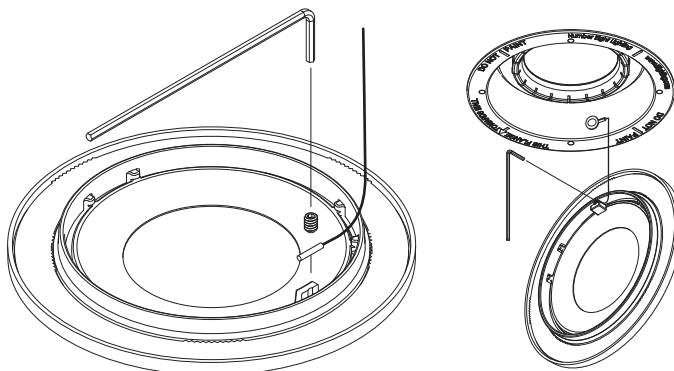

WIRING DIAGRAMS

PR1 / DIM3 - PHASE CONTROL

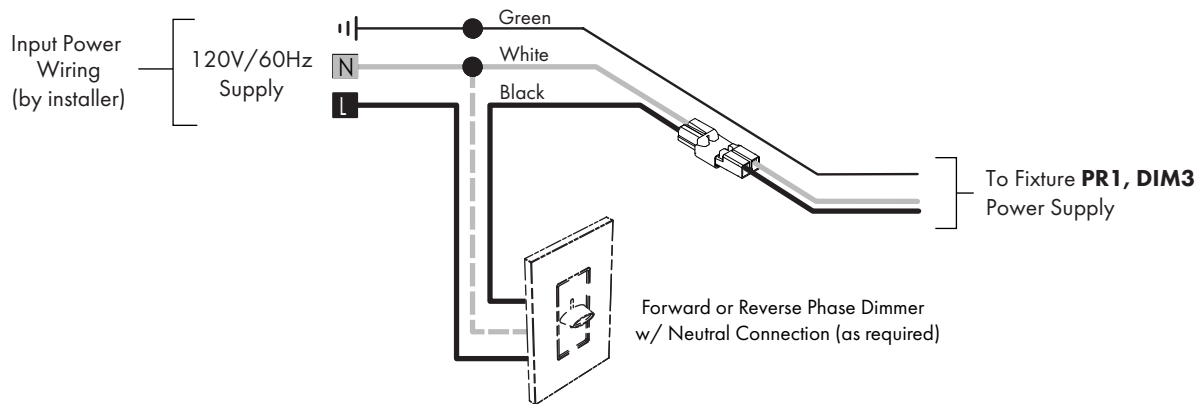

Phase Control Notes:

PR1 / DIM3 drivers are Forward or Reverse Phase dimmable.

For compatible dimmers for use with **PR1 / DIM3** drivers see: www.8lighting.com/resources-downloads

DIM4 / EL1 - 0-10V CONTROL

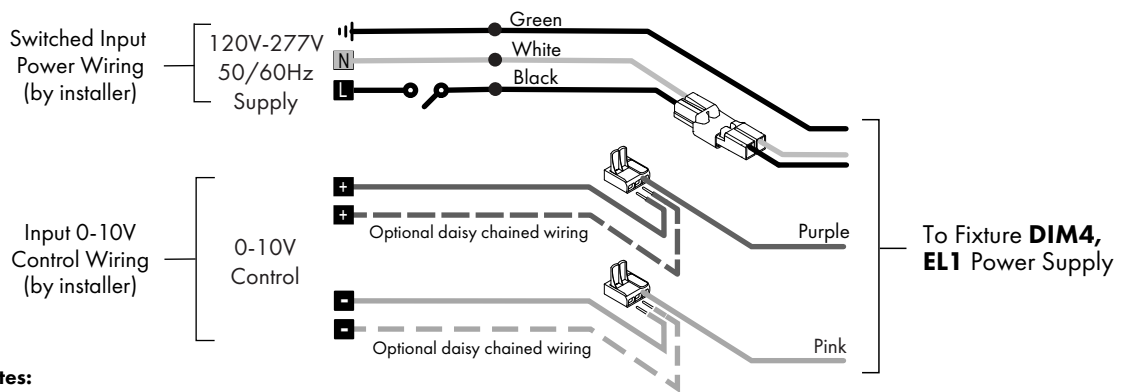

0-10V Control Notes:

0-10V control wiring is polarity sensitive and should be run as Class 2.

300' is the maximum control wiring run length to reduce EMI susceptibility and voltage drop. Voltage drop should be no greater than 0.3V.

For compatible dimmers for use with **DIM4 / EL1** drivers see: www.8lighting.com/resources-downloads.

EL2 - DALI CONTROL

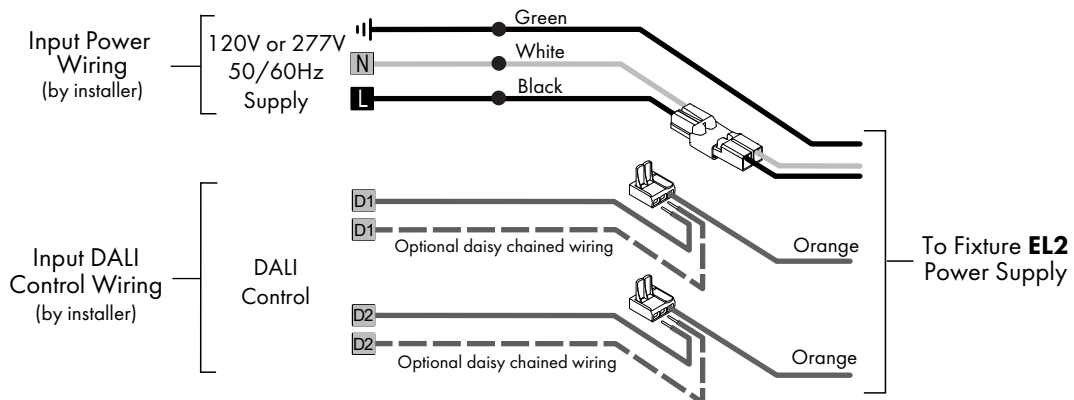

DALI Control Notes:

DALI control wiring is not polarity sensitive and can be run as Class 1 or 2. Up to 64 **EL2** power supplies can be daisy chained per DALI control loop.

Maximum control wiring run length is 1000'.

For compatible dimmers for use with **EL2** drivers see: www.8lighting.com/resources-downloads.

WIRING DIAGRAMS

LU2 / LU4 - LUTRON ECOSYSTEM CONTROL

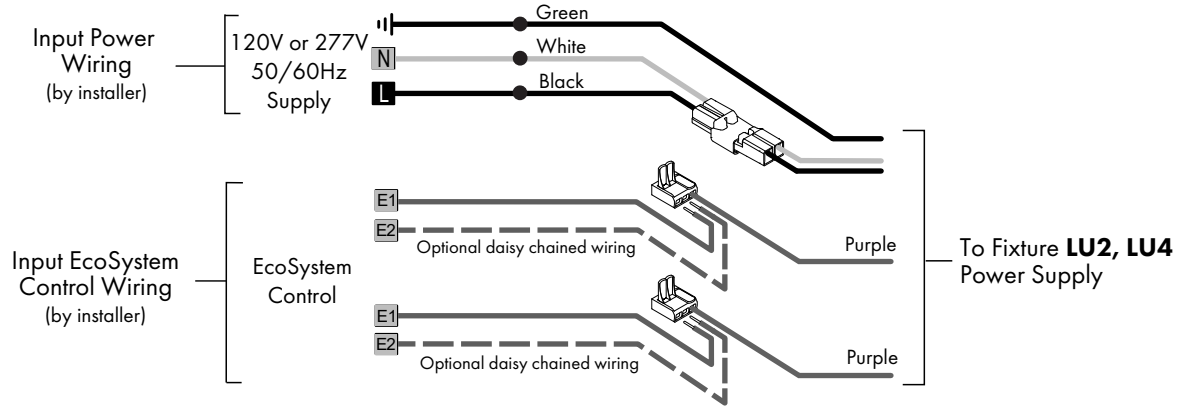

Lutron EcoSystem Control Notes:

Up to 64 **LU2 / LU4** power supplies can be daisy chained per EcoSystem control loop.
 Maximum control wiring run length is 1000'.

For additional information, contact LED Center of Excellence at 1.877.346.5338 or LEDs@lutron.com.



www.8lighting.com

Number Eight Lighting Company

526 Portal Street, Cotati, CA 94931

Phone (707) 794-0888 • Email customerservice@8lighting.com