



**800 SERIES
RETROFIT**
INSTALLATION INSTRUCTIONS



SCAN QR CODE FOR INSTRUCTIONS

WARNING: Read and understand these instructions completely before installation. Disconnect power at circuit breaker or fuse panel before installation. Always allow LED assembly to cool before servicing. To be installed by qualified electricians only. Products should be installed in accordance with these instructions, local electrical codes, and the National Electric Code (NEC). These products may represent a possible shock or fire hazard if improperly installed.

Do not install where insulation or ambient temperatures will exceed maximum values noted in product specifications. See www.8lighting.com for current product specifications.

NOTE: Number Eight Lighting fixtures are designed to meet the latest NEC requirements and are listed in full compliance with UL standards. Before attempting installation check and understand your local electrical code which sets the wiring standards and installation requirements for your locality.

Save these instructions.

TABLE OF CONTENTS

	PAGE
LEGACY COMPONENTS - INCANDESCENT & LED.....	1
RETROFIT COMPONENTS - LED.....	2
LEGACY INCANDESCENT LAMP MODULE REMOVAL.....	3-4
LEGACY LED LAMP MODULE REMOVAL.....	5
RETROFIT LABEL APPLICATION.....	6
INCANDESCENT POWER SUPPLY REMOVAL / RETROFIT - 801 & 802 HOUSINGS.....	7
LED POWER SUPPLY REMOVAL / RETROFIT - 801 & 802 HOUSINGS.....	8
LED POWER SUPPLY REMOVAL / RETROFIT - 803 HOUSINGS.....	9
LAMP MODULE J2 INSTALLATION / ADJUSTMENT.....	10-11
LAMP MODULE M2 INSTALLATION / ADJUSTMENT.....	12
WIRING DIAGRAMS.....	13-14

LEGACY COMPONENTS - INCANDESCENT & LED

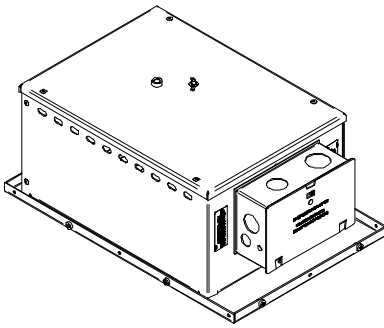
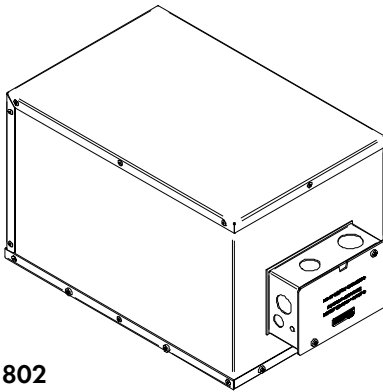
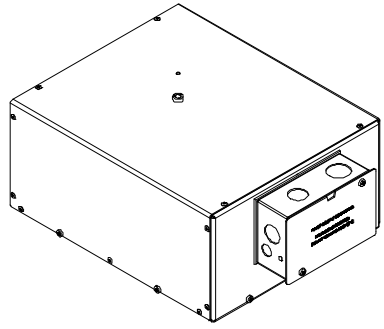
Legacy Housings		
 <p>801</p>	 <p>802</p>	 <p>803 Single & Multi-lamp</p>

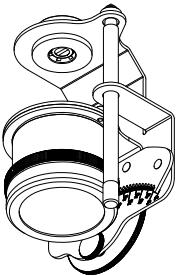
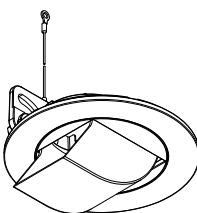
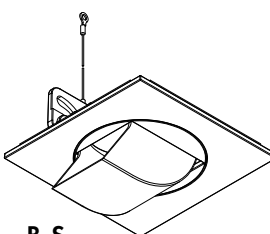
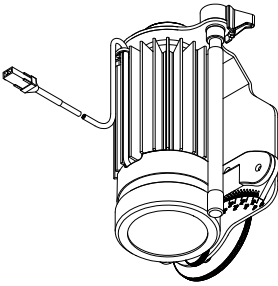
Legacy Incandescent Lamp Modules				Legacy LED Lamp Modules	
 <p>A</p>	 <p>B-R</p>	 <p>B-S</p>	 <p>J</p>		

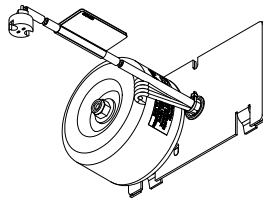
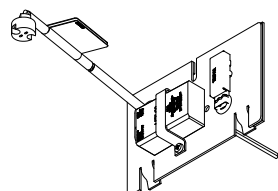
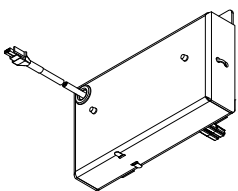
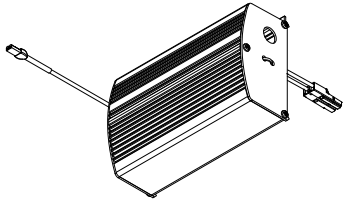
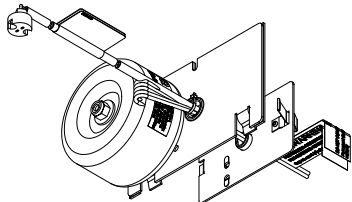
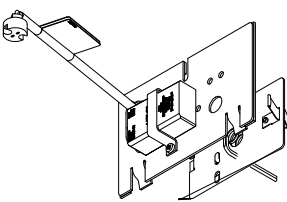
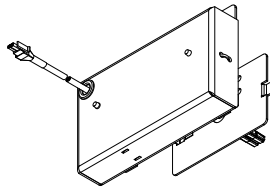
Legacy Power Supplies					
801 Housing	 <p>QT (Non-IC)</p>	 <p>ET (Non-IC)</p>	 <p>LED (Non-IC)</p>	803 Housings	 <p>LED (IC)</p>
802 Housing	 <p>QT (IC)</p>	 <p>ET (IC)</p>	 <p>LED (IC)</p>		

RETROFIT COMPONENTS - LED

Retrofit LED Lamp Modules

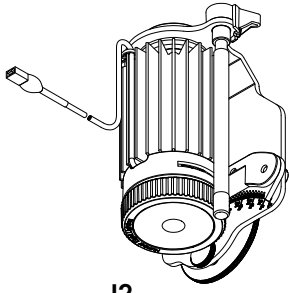

J2

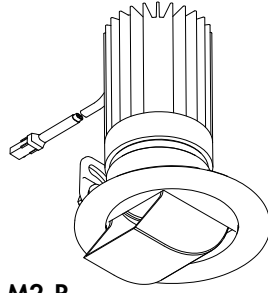

M2-R

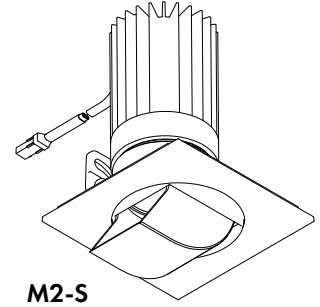

M2-S

Retrofit LED Power Supplies

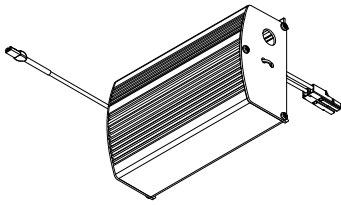

801 & 803 Housings

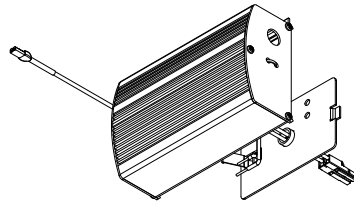

802 Housing

RETROFIT INSTRUCTIONS

Removing Legacy Incandescent Lamp Module A

- STEP 1** Loosen Lock Shaft before removing Lamp Module - **FIG 3.1**
- STEP 2** Adjust Lamp Module to 0 position - **FIG 3.2.**
- STEP 3** Remove Lamp Rings Lens & Lens Holder to expose Shoulder Bolt - **FIG 3.2.**
- STEP 3** Using flat blade screw driver, loosen Shoulder Bolt to Housing - **FIG 3.2 & FIG 3.3.**
- STEP 4** Pull Lamp Module through aperture & disconnect Lamp socket from lamp - **FIG 3.2 & FIG 3.4.**

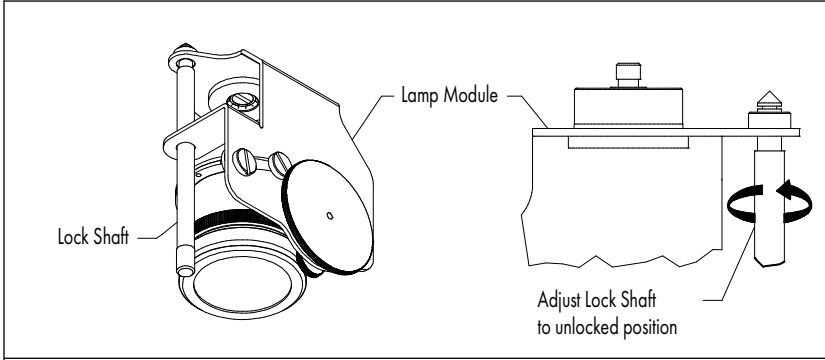

FIG 3.1 Preparing Lamp Module for installation

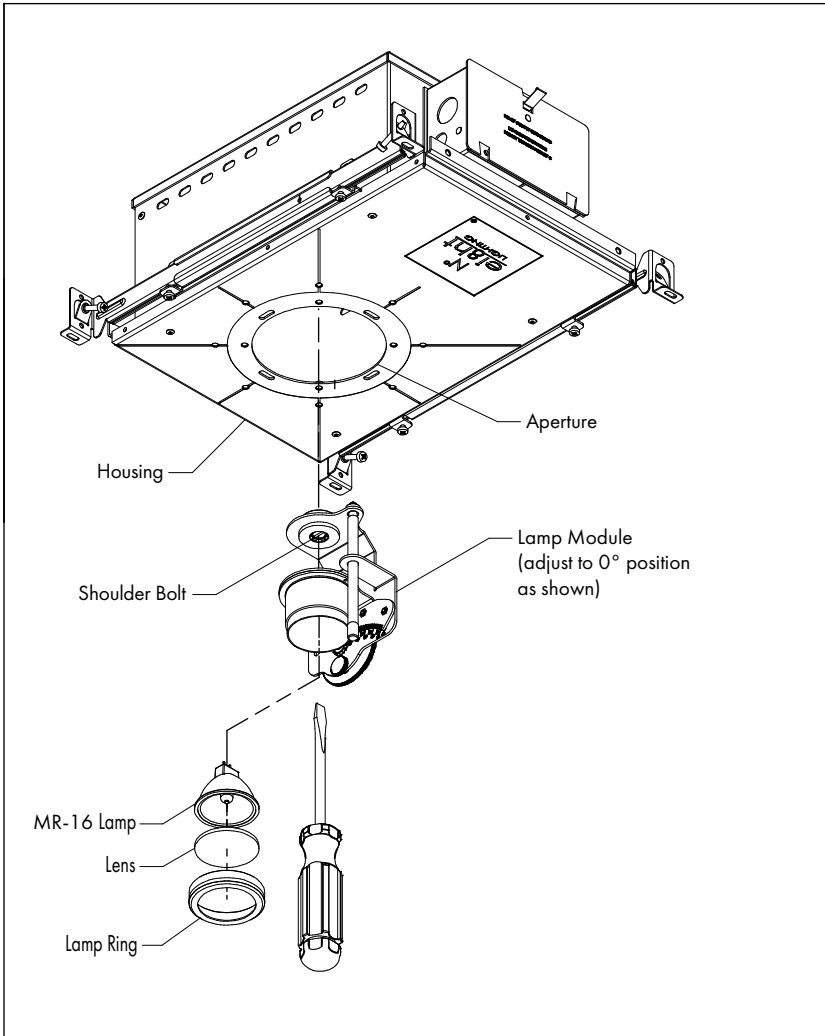

FIG 3.2 Removing Lamp Module A

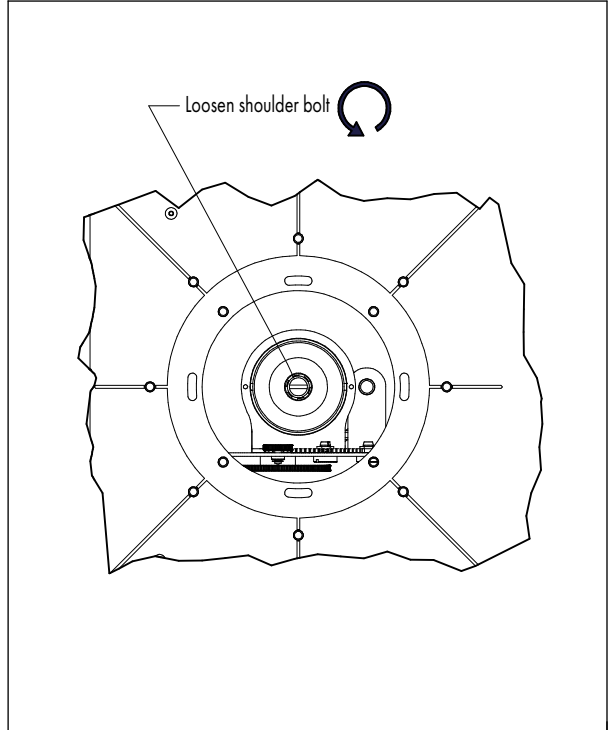

FIG. 3.3 Loosen Should Bolt

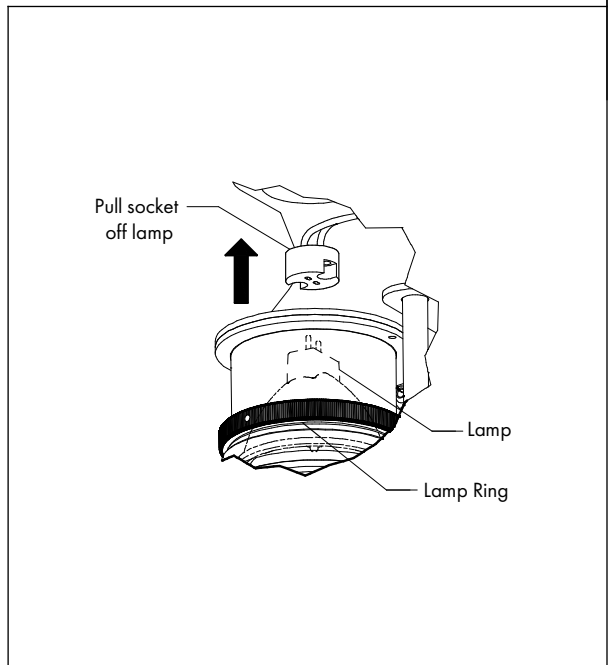

FIG 3.4 Disconnecting Lamp Socket

RETROFIT INSTRUCTIONS

Removing Legacy Incandescent Lamp Modules B & H

Remove Lamp Modules B & H:

STEP 1 Remove Lamp Module B or H from Trim in Housing & pull lampholder from Lamp pins - **Fig 4.2.**

STEP 2 Detach Safety Cable to Cable Clip to fully remove Lamp Module from ceiling aperture- **Fig 4.2.**

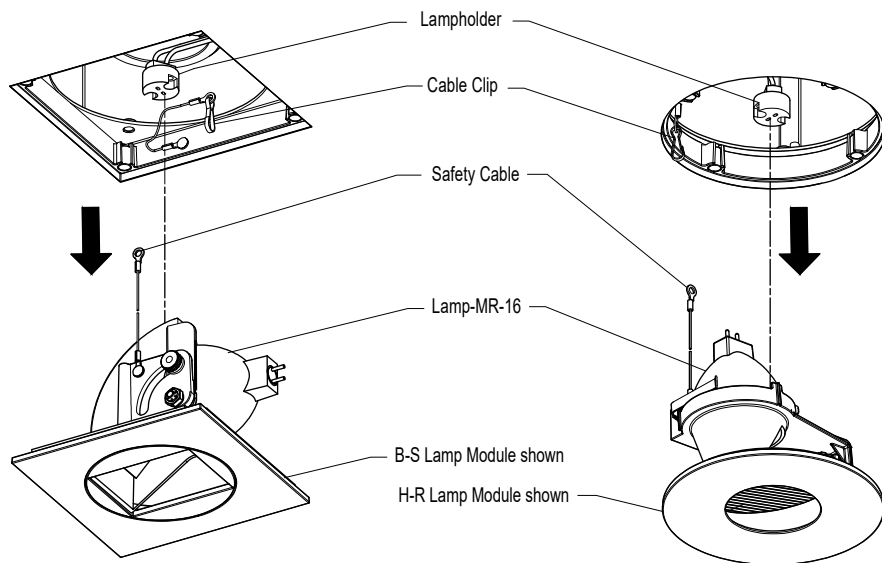

FIG 4.2 Remove Lamp Modules B & H

RETROFIT INSTRUCTIONS

Removing Legacy LED Lamp Modules J & K

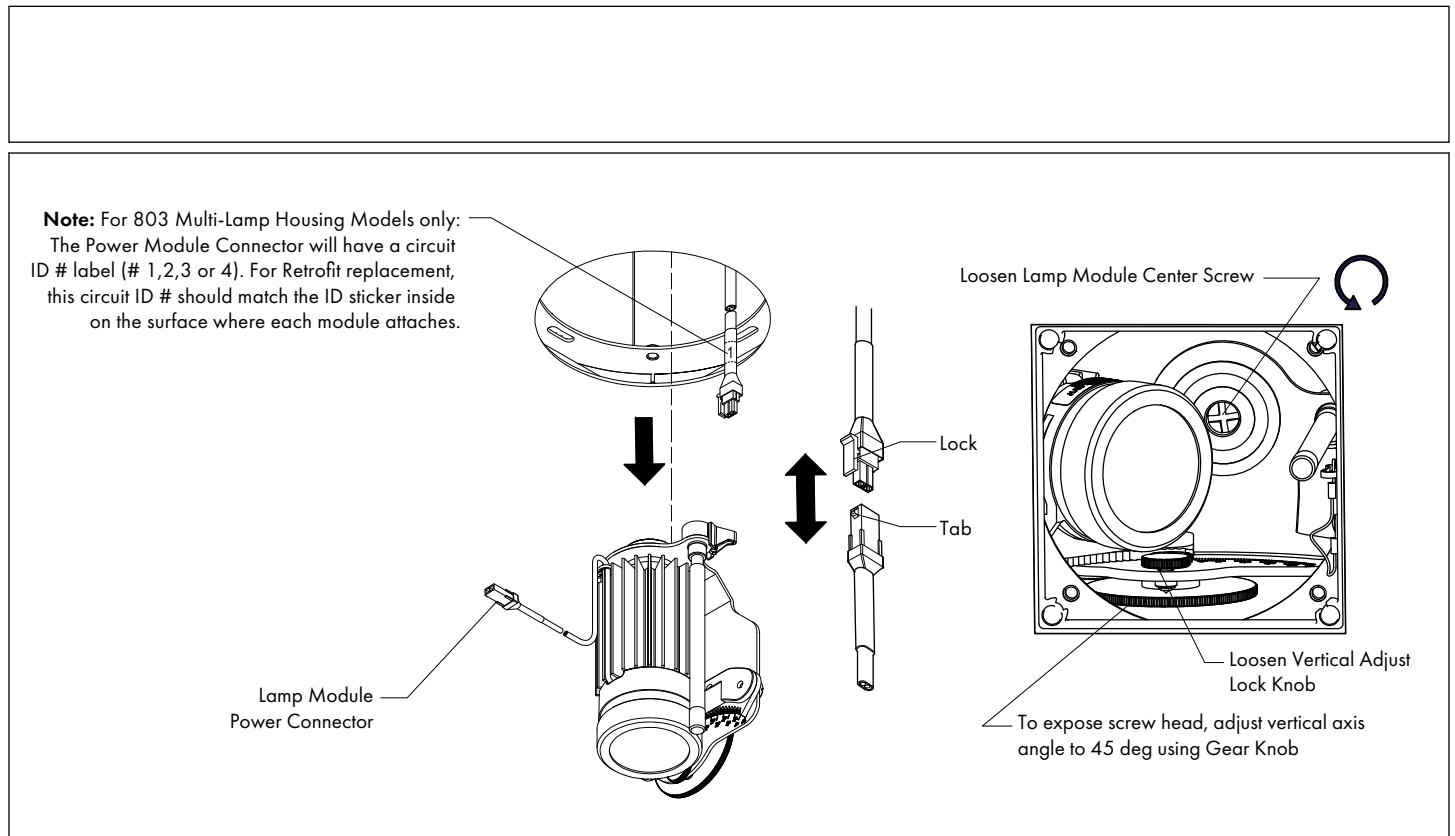

FIG 5.1 Remove Lamp Module J

Remove Lamp Module K:

STEP 1 Locate and disconnect Lamp Module Power Connector - **Fig 5.2.**

STEP 2 Loosen Lamp Module K from Housing by rotating counter clockwise & remove through ceiling aperture & Disconnect wire connectors - **Fig 5.2.**

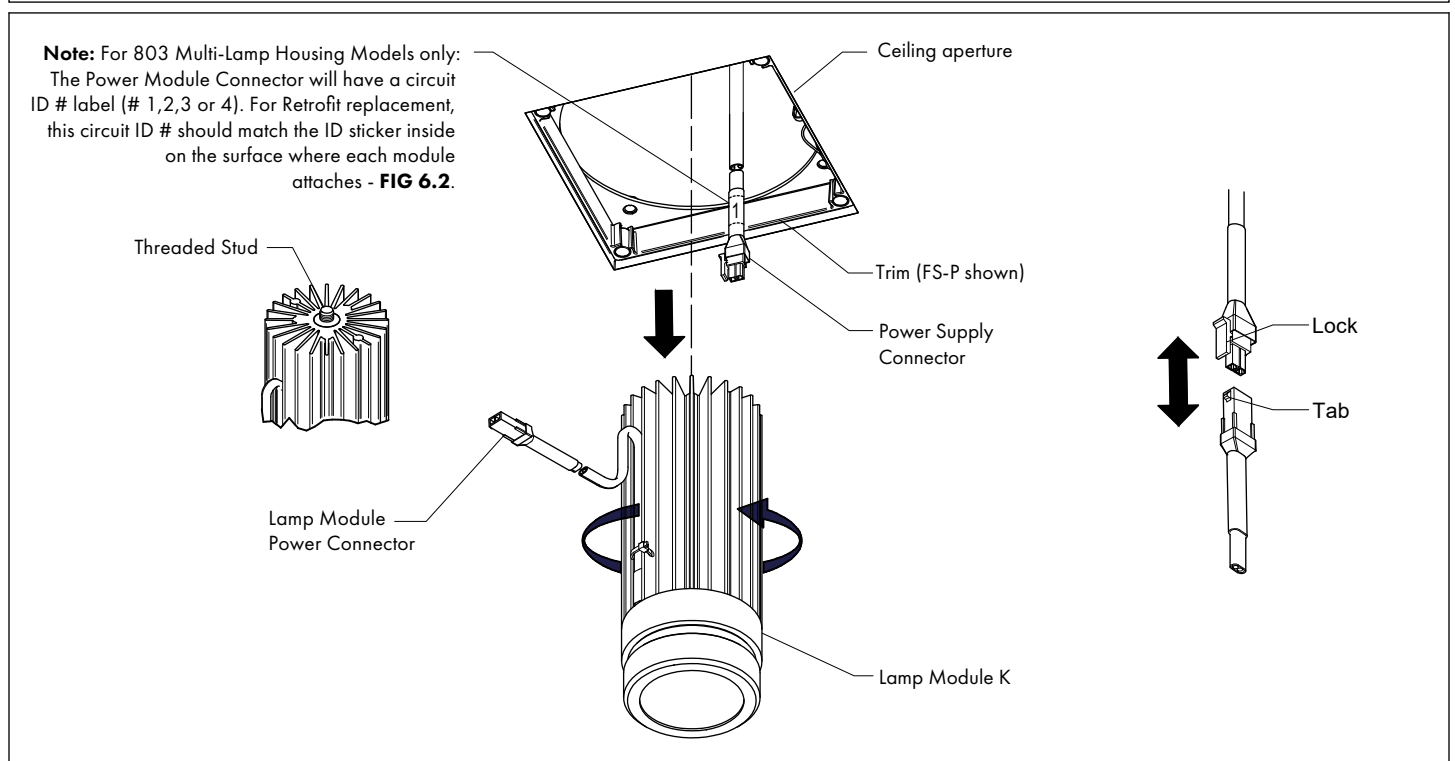

FIG 5.2 Remove Lamp Module K

RETROFIT INSTRUCTIONS

Retrofit Label Application - 801 & 802 Housings

Important: To retrofit from Incandescent to LED, the supplied Retrofit Label shown below is required for 801 & 802 housings.
 Before installing the retrofit Lamp Module, place the Retrofit Label onto the Rough-in Section label located inside the 801 or 802 housing - **FIG 6.1**.

J2, K2, L2, M2

STEP 1 Remove the old lamp module (see **Pages 3-5**) & power supply (see **Pages 7-8**) from 801 or 802 housing.

Important: Clean the area for the Patch Label before applying.

STEP 2 Peel the backing off of the Retrofit label & adhere label on top of the existing lamp module letters found on the Rough-in Section Label completely covering the old lamp model designations- **FIG 6.1**.

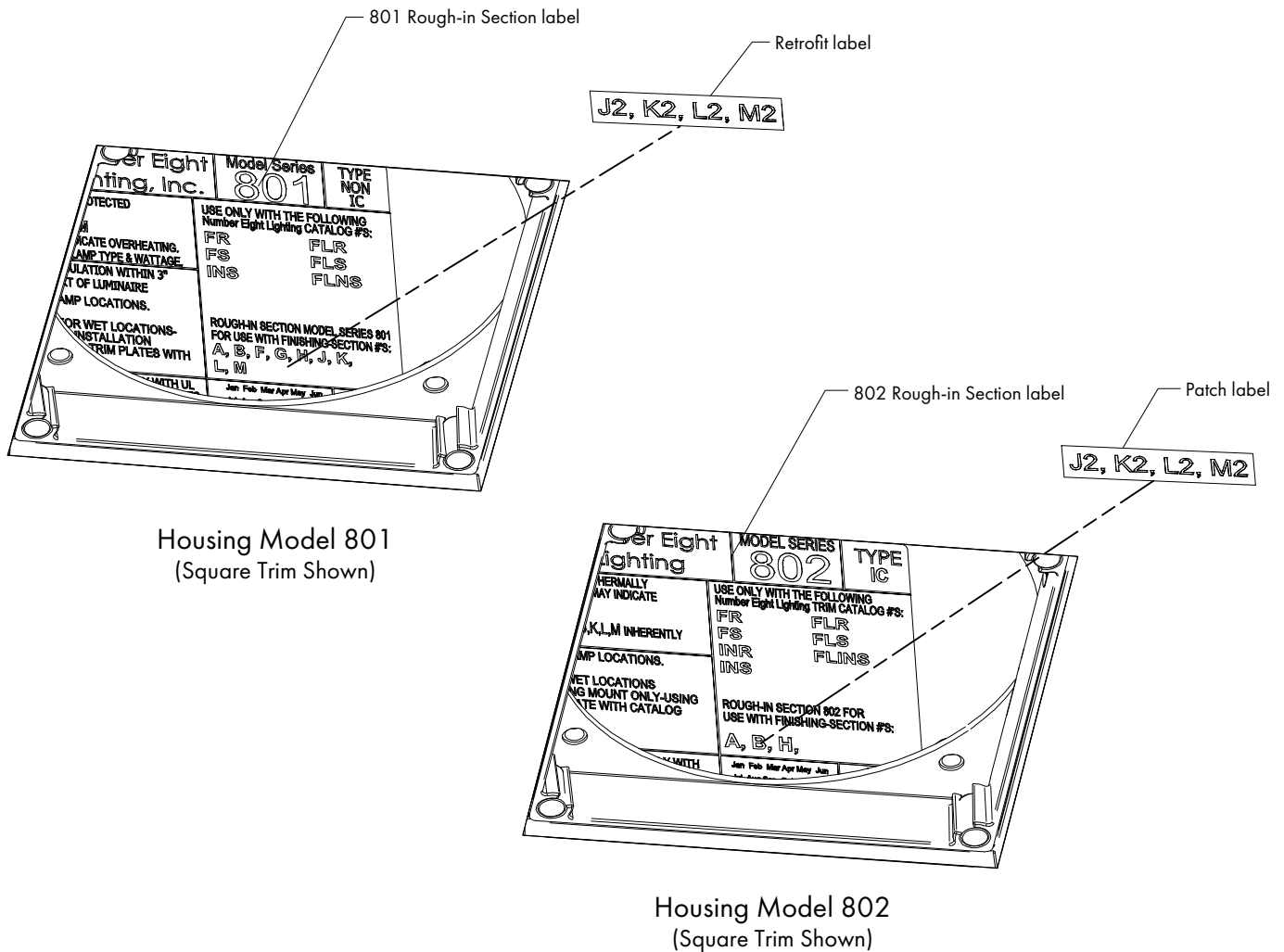

FIG 6.1 Applying Retrofit Label

RETROFIT INSTRUCTIONS

Remove Incandescent Power Supply - 801 / 802 HOUSINGS

⚠ CAUTION:

- ▶ Disconnect power at circuit breaker panel before proceeding.
- ▶ Always allow lamp to cool before removing.

For removing Legacy Lamp Modules - see Pages 3-5.

For Wiring Diagrams - see Pages 13-14

STEP 1 Remove Lamp Module from Housing (refer to specific lamp Module page).

STEP 2 Reach inside far end of Housing & remove Thumb Knob - **FIG 7.1**.

STEP 3 Disengage Power Supply Module from back of housing (refer to illustrations below). Supply wires will now be exposed - **FIG 7.2**.

STEP 4 Make note of wire color connections and disconnect Transformer supply wires from field supply wires in junction box.

STEP 5 Pull Power Supply Subassembly through aperture - **FIG 7.3**.

Replace: Install LED Retrofit Power Supply using steps above in reverse order. Reconnect wiring according to previous color connections. Push all connections inside junction box.

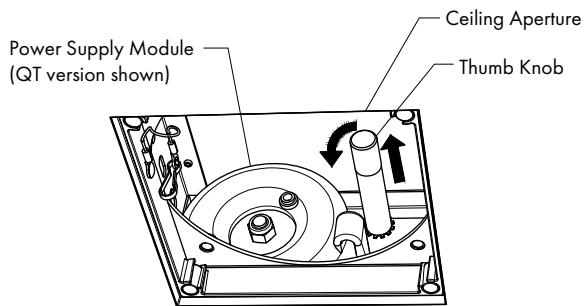

FIG 7.1 Remove Thumb Knob

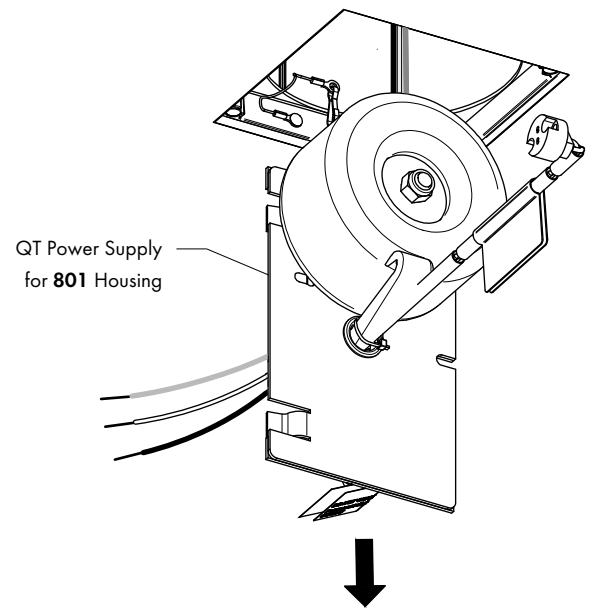

FIG 7.3 Remove Power Supply from 801 Housing

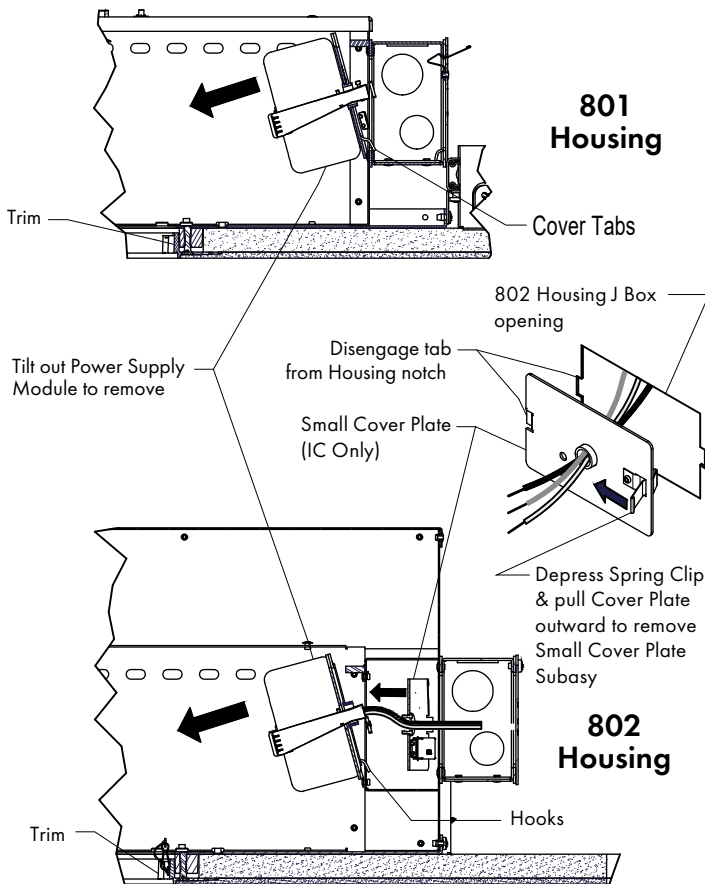

FIG 7.2 Disengage Power Supply Module

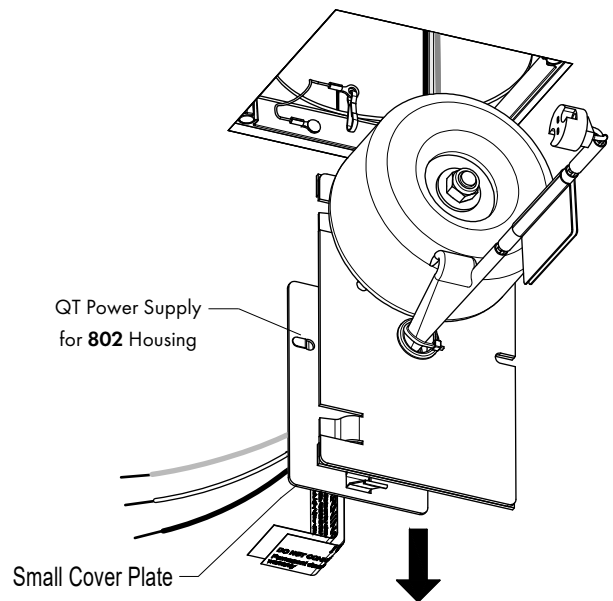

FIG 7.4 Remove Power Supply from 802 Housing

RETROFIT INSTRUCTIONS

LED Power Supply Module Removal / Replacement - 801 / 802 Housings

CAUTION: ▶ Turn off power at wall switch & review all instructions on this page before proceeding.
▶ Always allow lamp module to cool before servicing.

For removing Legacy Lamp Modules - see Pages 3-5.
For Wiring Diagrams - see Pages 13-14

Remove LED Power Supply Module:

STEP 1 Unscrew & remove Thumb Knob inside Housing as shown - **FIG 8.1** & **8.2**.

STEP 2 Tilt & lift Power Supply Module to disengage - **FIG 8.3**.

STEP 3 Pull Power Supply Module through ceiling aperture & disconnect Power Supply wire connectors - **FIG 8.4**.

For Retrofit Replacement: Replace all parts in steps above in reverse order. Be sure hooks engage into junction box

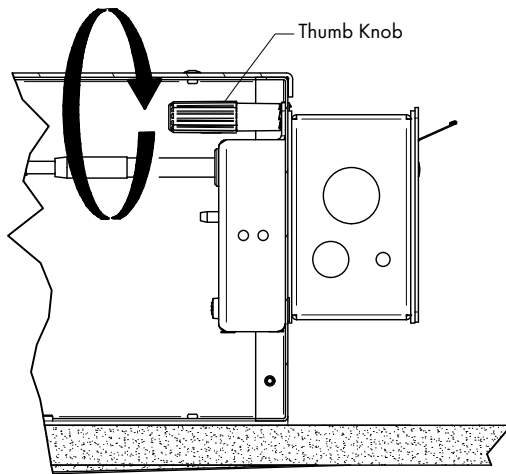

FIG 8.1 Remove Thumb Knob

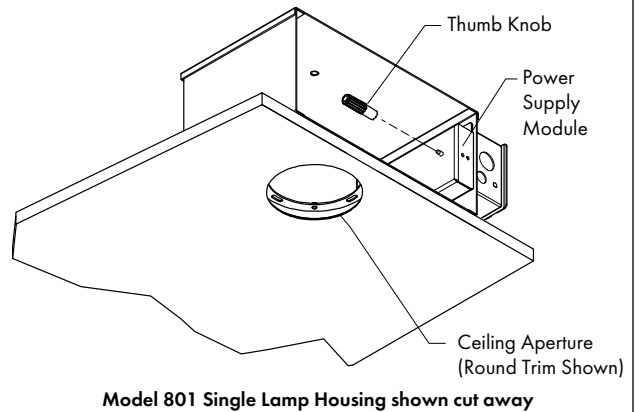

FIG 8.2 Disengage Power Supply Module

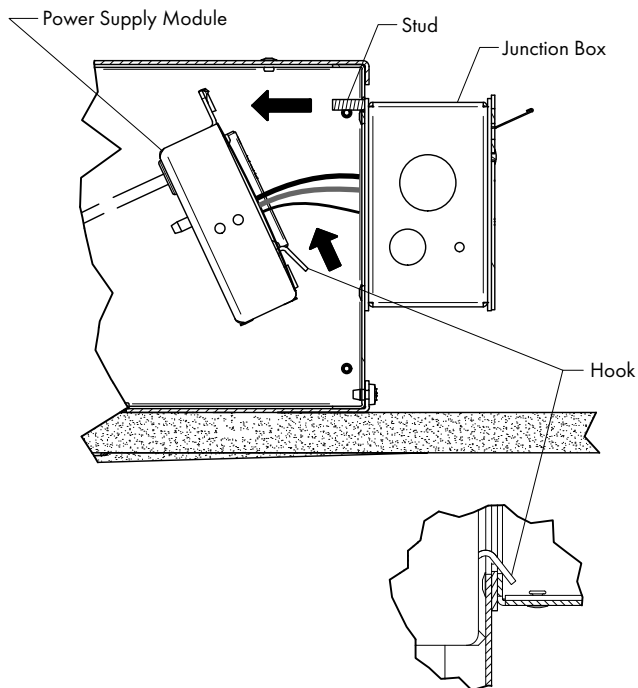

FIG 8.3 Disengage Power Supply Module

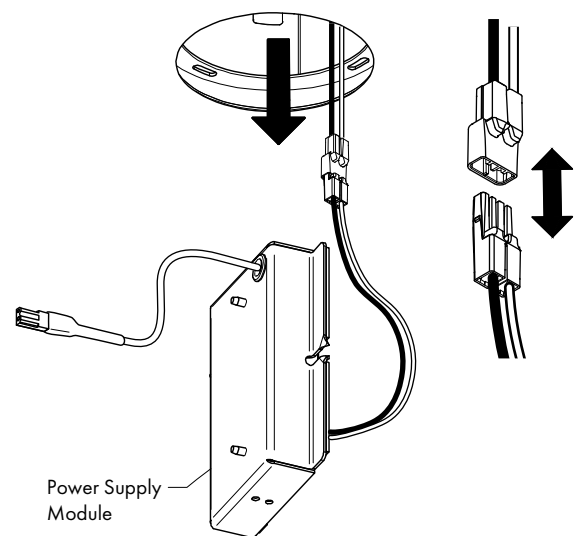

FIG 8.4 Remove Power Supply Module

RETROFIT INSTRUCTIONS

LED Power Supply Module Removal / Replacement - 803 Housings

CAUTION: ▶ Turn off power at wall switch & review all instructions on this page before proceeding.
▶ Always allow lamp module to cool before servicing.

For removing Legacy Lamp Modules - see Pages 3-5.
For Wiring Diagrams - see Pages 13-14.

Remove LED Power Supply Module:

STEP 1 Unscrew & remove Thumb Knob inside Housing- **FIG 9.1**.

STEP 2 Tilt & lift Power Supply Module to disengage - **FIG 9.1**.

STEP 3 Pull Power Supply Module through ceiling aperture & disconnect all wire connectors - **FIG 9.4**.

For Retrofit Replacement: Replace all parts in steps above in reverse order. Be sure hooks engage into junction box as shown in **FIG 9.4**.

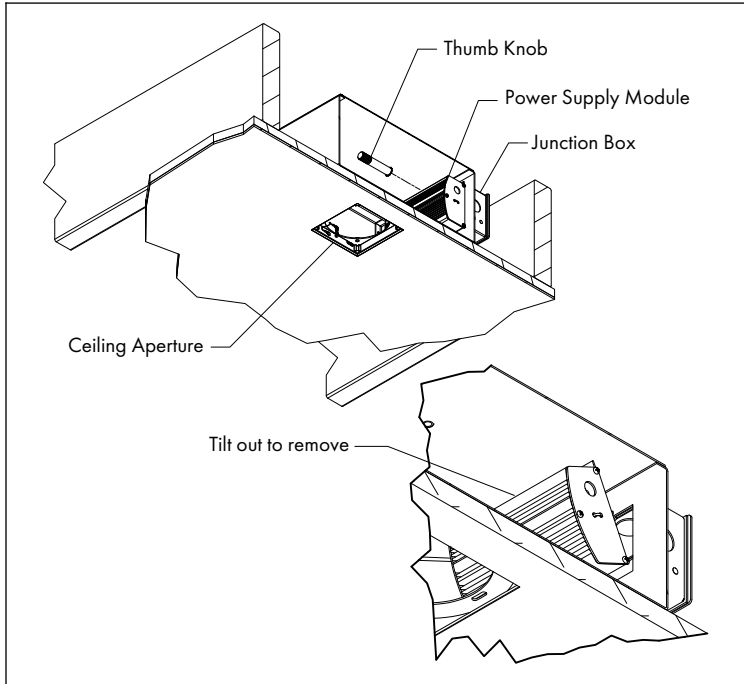

FIG 9.1 Remove Thumb Knob & Disengage Power Supply Module

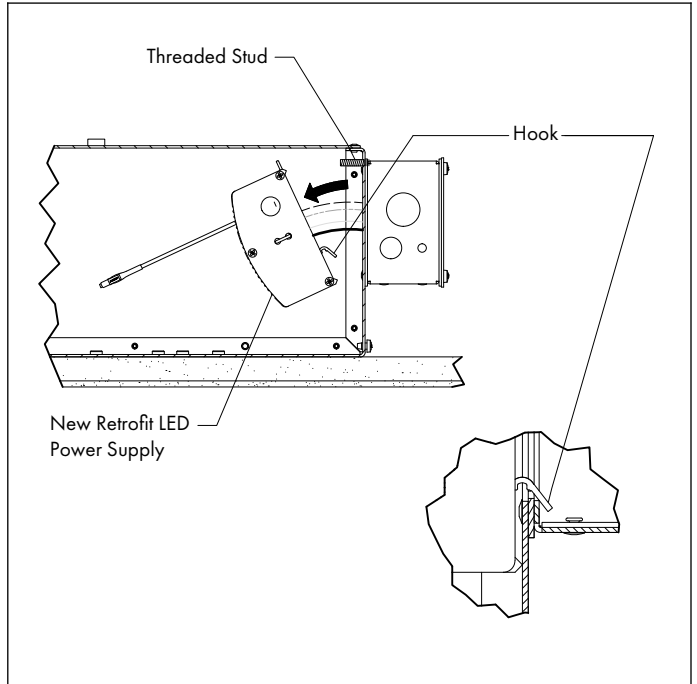

FIG 9.2 Disengage Power Supply Module & disconnect wires

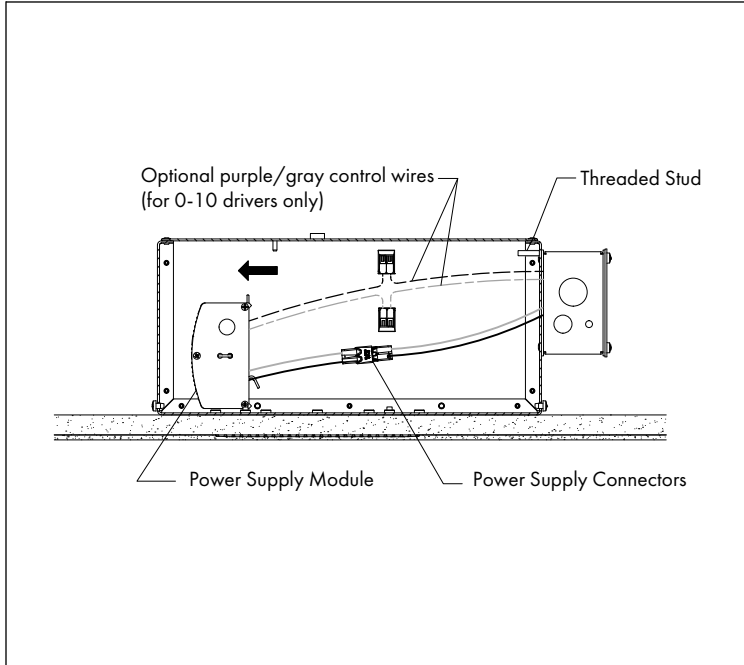

FIG 9.3 Determine Wire Connections

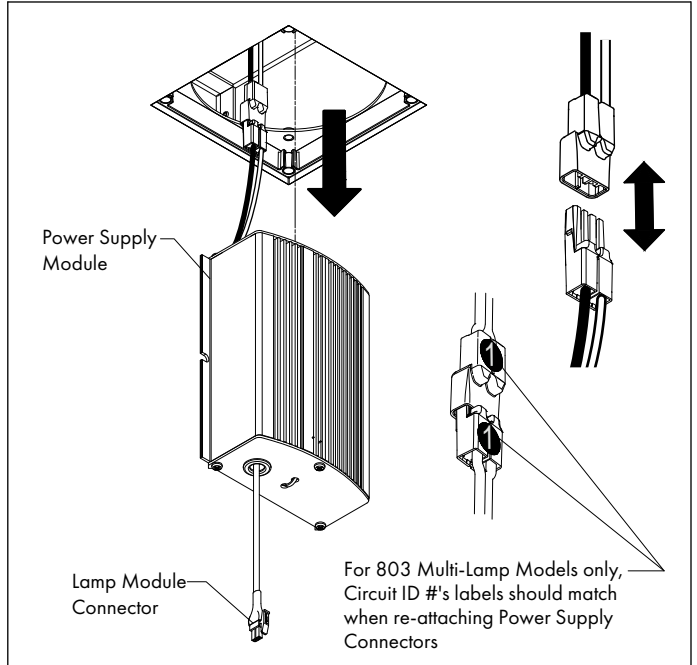

FIG 9.4 Replace with Retrofit Power Supply Module

RETROFIT INSTRUCTIONS

Lamp Module J2 Installation / Removal / Adjustment

CAUTION: Turn off power at wall switch & review all instructions on this page before proceeding.
Always allow lamp module to cool before servicing.

Installation:

Step 1 Before installing Lamp Module, make sure correct LED Power Supply Module is installed & Lock Shaft is in unlocked position - **FIG 10.1**.

Step 2 Insert Lamp Module into housing as shown then adjust to 45° position to expose Shoulder Bolt. Secure Shoulder Bolt to Housing Center Nut - **FIG 10.2 & 10.3**.

Step 3 Plug Wire Connector from Lamp Module into Power Supply Module connector. Push wire up inside housing to avoid interference during adjustment - **FIG 10.2**.

Adjustment: Adjust desired horizontal position & vertical aiming angle as shown in **FIG 10.4**.

Removal: To remove lamp module follow steps above in reverse order.

Replacement: Contact Number Eight Lighting for replacement Lamp Module or LED emitter.

Optional Accessories: Unscrew Lamp Ring to add/ remove accessories - **FIG 10.2**.

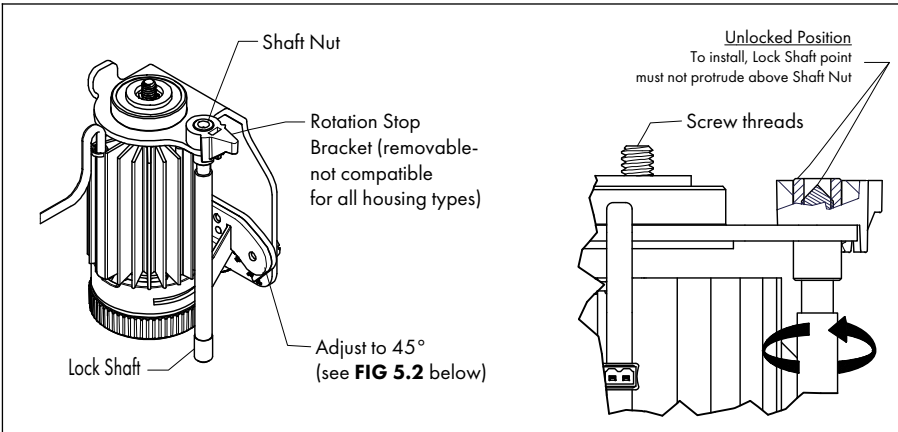
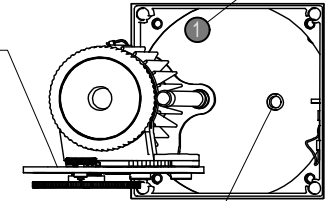

FIG 10.1 Preparing Lamp Module J2 for installation

Circuit ID# for 803 Multi-Lamp Models only

Do Not rotate Lamp Module to secure to housing



Tighten Screw to Housing Center Nut

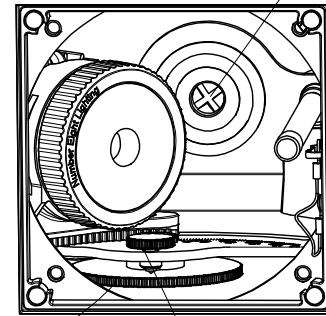

FIG 10.3 Securing Lamp Module to Housing

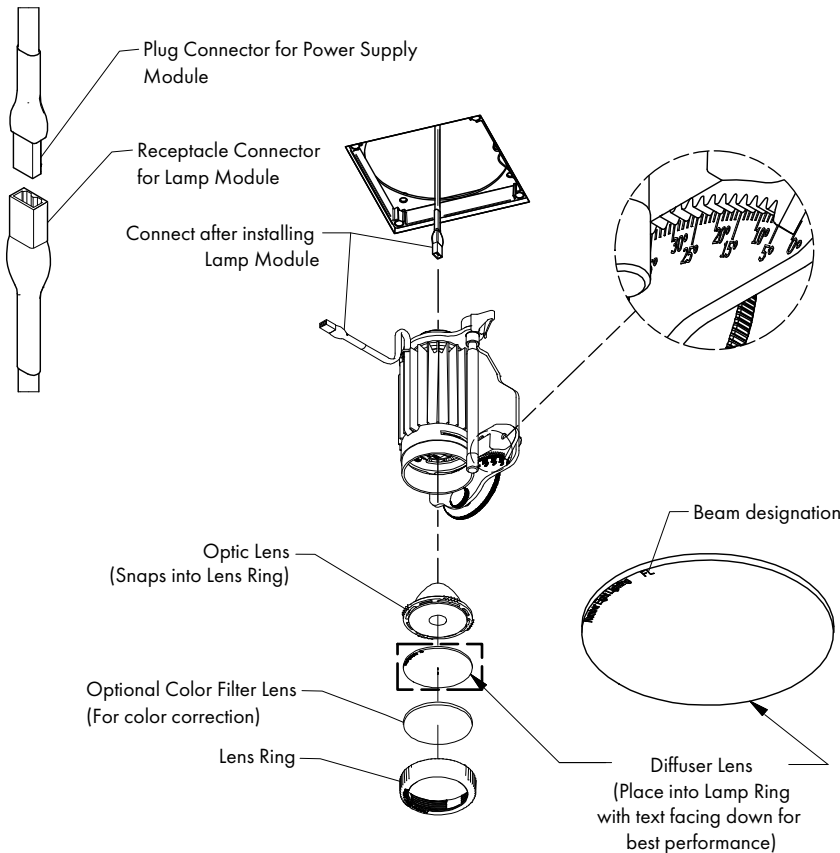

FIG 9.2 Installing Lamp Module J2

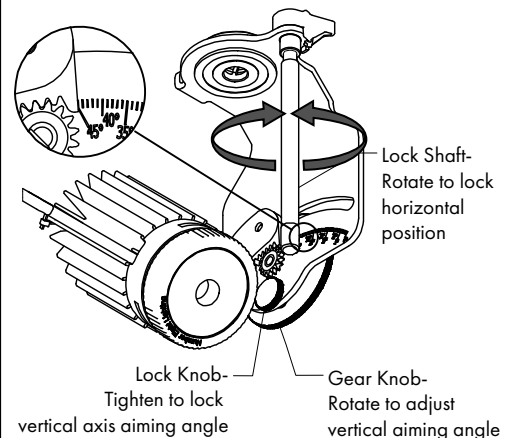

FIG 9.4 Aiming Adjustment

RETROFIT INSTRUCTIONS

WW-8 Wall Wash Trim Plate Installation

Important: WW-8 Trim Plates can only be used with J2 Lamp Modules. Use 40° TIR Optic with HI, HI-3, WD, WD-2, WD-4 or TW LED for optimal performance. Use 10° optic and FL lens with HI-2 LED.

STEP 1 Unlock & adjust J Lamp Module to 20° vertical aiming angle for optimal wall wash performance - **FIG 11.1**.

STEP 2 Unlock & adjust horizontal position to aim light towards wall surface to be illuminated- **FIG 11.2**.

STEP 3 Orient & install Wall Wash Trim Plate into Trim as shown - **FIG 11.3**.

Note: Magnets will permit Trim Plates to only be installed in 4 horizontal orientations.

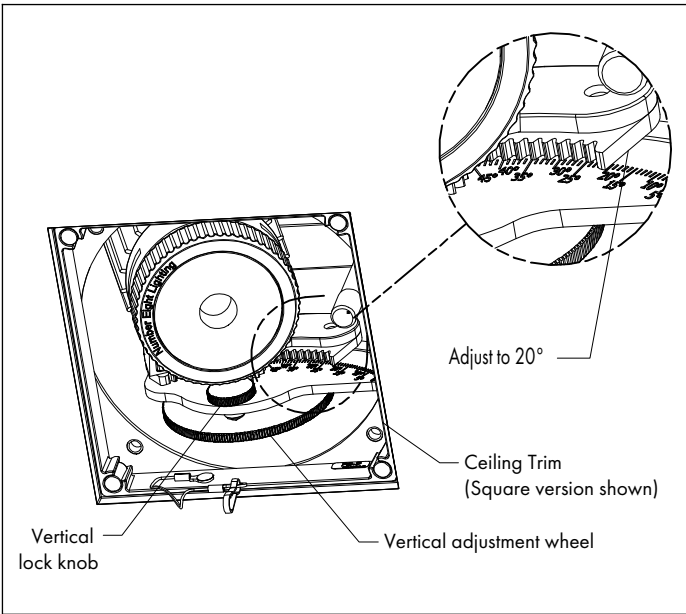

FIG 11.1 Adjust Vertical Aiming Angle

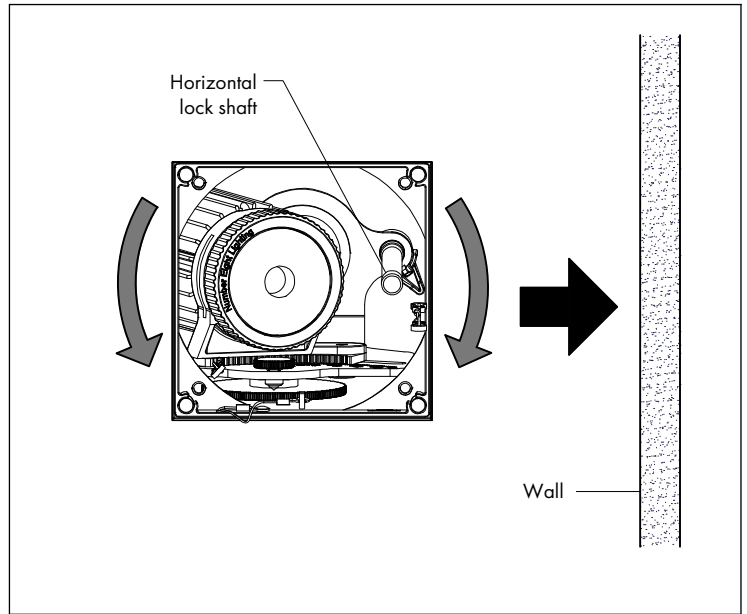

FIG 11.2 Adjust Horizontal position

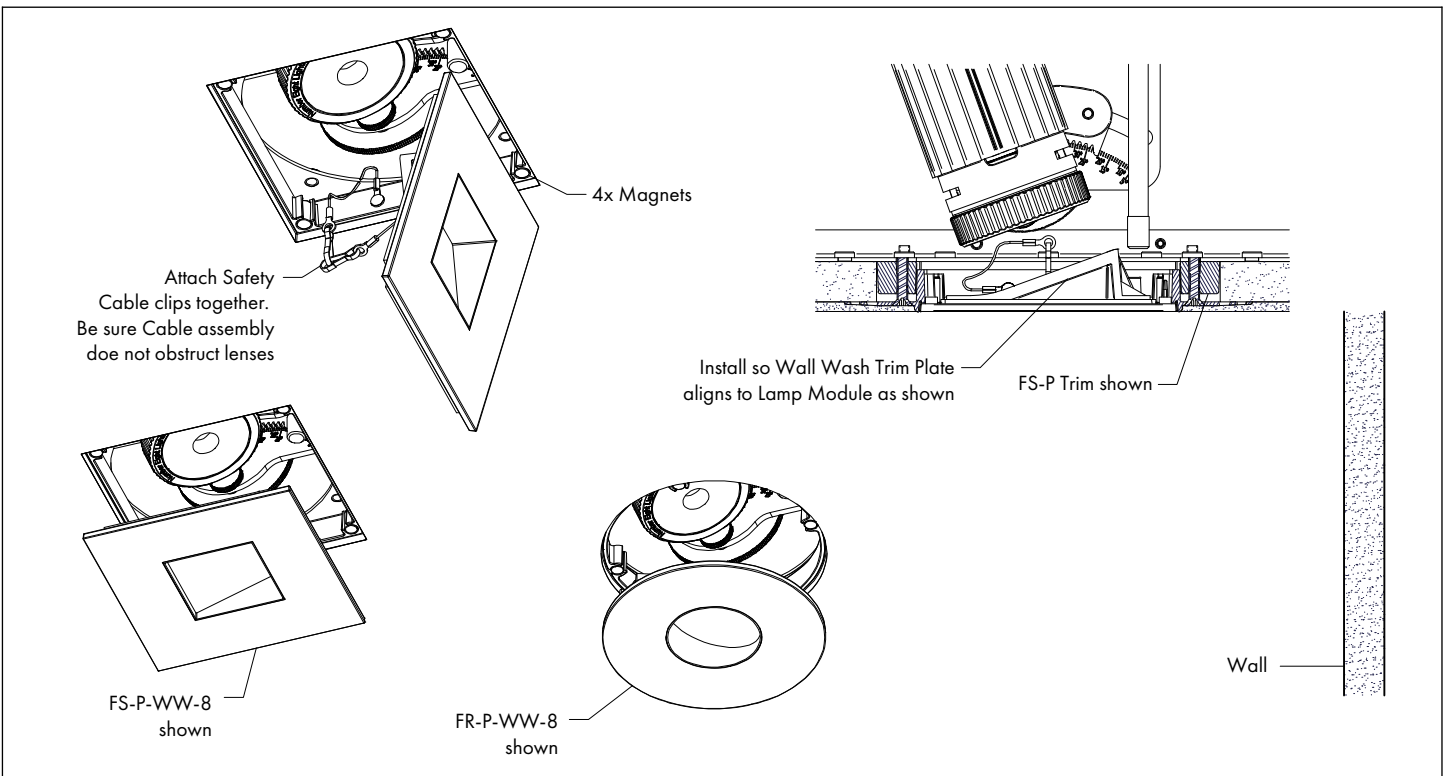

FIG 11.3 Install Wall Wash Trim Plate

RETROFIT INSTRUCTIONS

Lamp Module M2 - Install / Remove / Adjust

Installation:

Step 1 Before installing Lamp Module, make sure LED Power Supply Module is installed.

Note: For Sloped Ceilings Only-See recommended Housing installation orientation - **FIG 12.1**.

Step 2 Adjust vertical to 90 deg position as shown in **FIG 12.3**. Note: angle adjustment is limited on ceilings over 5/8" thick & when Mirror Reflector is aligned facing narrow sides of Housing.

Step 3 Plug Wire Connector from Lamp Module into Power Supply Module Connector. Push wire up inside Housing to avoid interference during installation - **FIG 12.4**.

Step 4 Choose general aiming position desired. Attach Safety Cable from Trim Cable Clip to Lamp Module before inserting Lamp Module through Housing aperture. Seat Trim Plate into Trim as shown.

Note: horizontal & vertical aiming position adjustment is lockable using Lock Knobs. General aiming position is easily changed by pulling **J2** Lamp Module out slightly & rotating into one of 4 positions - **FIG 12.2 & 12.3**.

Removal: To remove Lamp Module follow steps above in reverse order.

Replacement: Contact Number Eight Lighting for replacement LED Engine Subassy or LED emitter. Remove Lamp Module & unscrew LED Engine Subassy for replacement or access to LED emitter.

Optional Accessories: Unscrew LED Engine Subassy to add/remove Lens accessories - **FIG 12.2**.

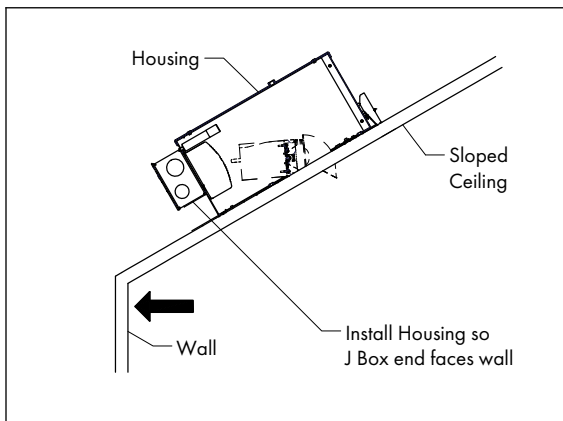

FIG 12.1 Housing Orientation for Sloped Ceiling

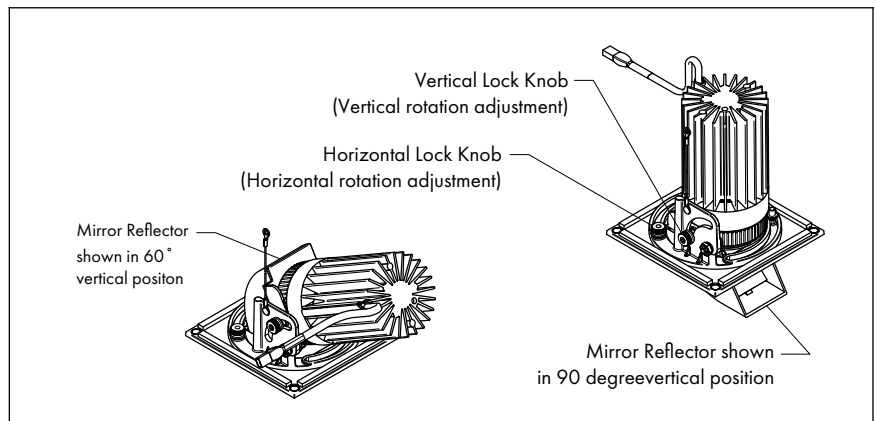

FIG. 12.3 Lamp Module Adjustment

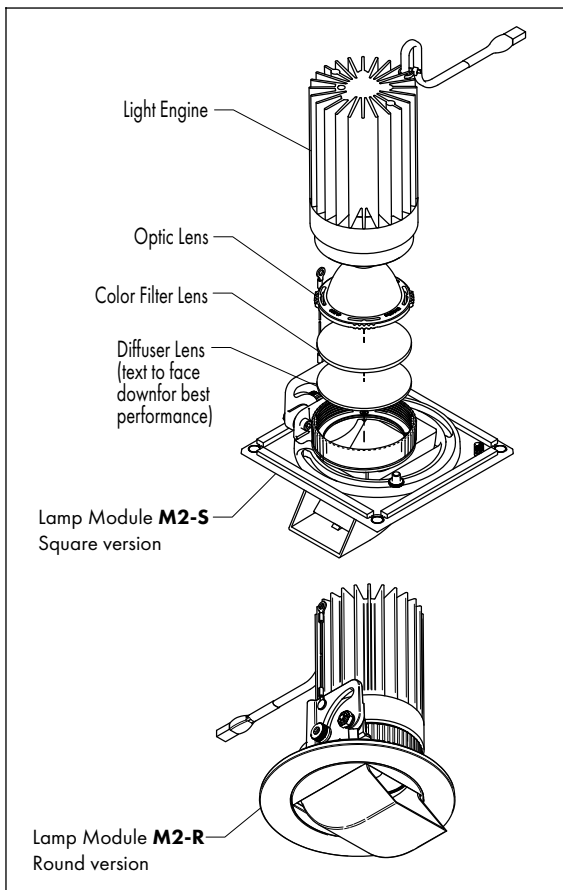

FIG 12.2 Installing Lamp Module Accessories

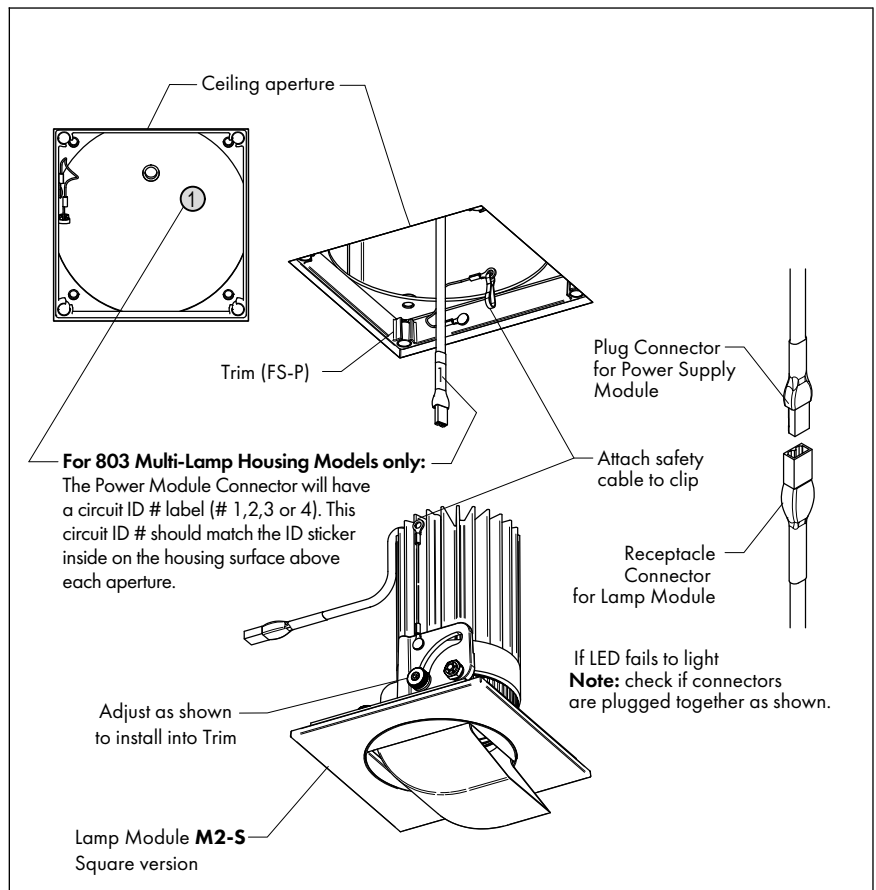

FIG 12.4 Securing Lamp Module to Housing & Trim

RETROFIT INSTRUCTIONS

WIRING DIAGRAMS

WIRING INSTRUCTIONS

For PR1 / EL1 / EL2 / LU2 / LU4 Dimming Options

CAUTION: TO AVOID RISK OF FIRE OR ELECTRIC SHOCK

Turn off power at circuit breaker or fuse panel and read instructions completely before proceeding.

Failure to follow instructions may void warranty. Save these instructions.

- Installation must be by a qualified electrician only and must conform to National Electric code and local regulations.
 - Verify correct dimming system, lamp module, power supply type, and input supply requirements.
 - Always allow LED assembly to cool before servicing.
 - Do not install where insulation or ambient temperatures will exceed maximum values noted in product specifications.
- See www.8lighting.com for current product specifications.

PR1 - PHASE CONTROL

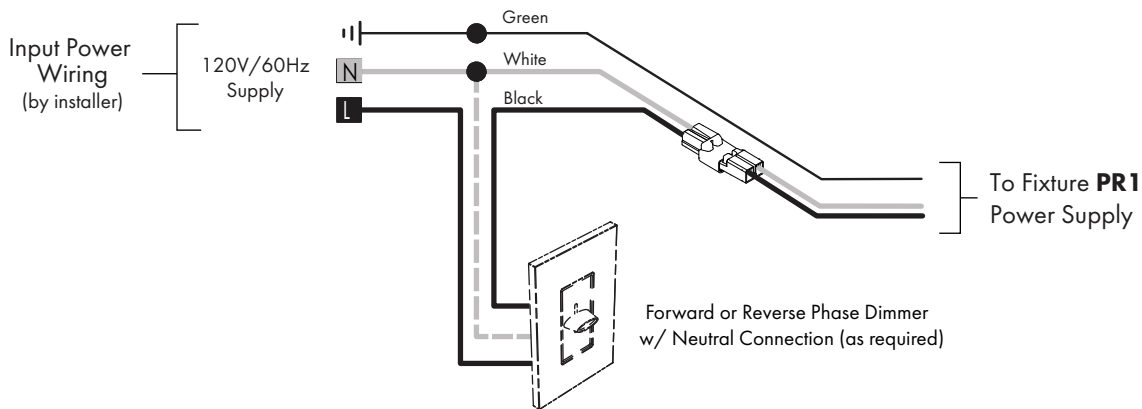

Phase Control Notes:

PR1 drivers are Forward or Reverse Phase dimmable.

For compatible dimmers for use with **PR1** drivers see: www.8lighting.com/resources-downloads

NOTE: For compatible dimmers for use with **PR1** drivers see www.8lighting.com/resources-downloads/

FIG 13.1 Wiring Diagram

EL1 - 0-10V CONTROL

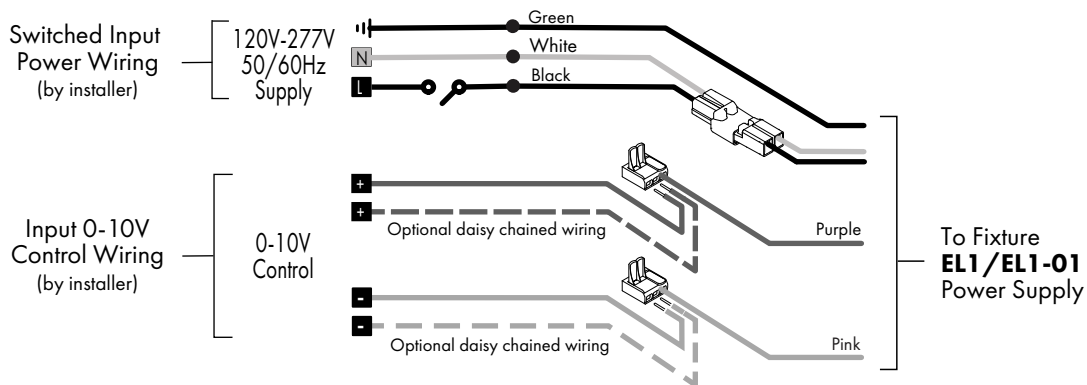

0-10V Control Notes:

0-10V control wiring is polarity sensitive and should be run as Class 2.

300' is the maximum control wiring run length to reduce EMI susceptibility and voltage drop. Voltage drop should be no greater than 0.3V.

For compatible dimmers for use with **EL1** drivers see: www.8lighting.com/resources-downloads

FIG 13.2 Wiring Diagram

WIRING DIAGRAMS

EL2 - DALI CONTROL

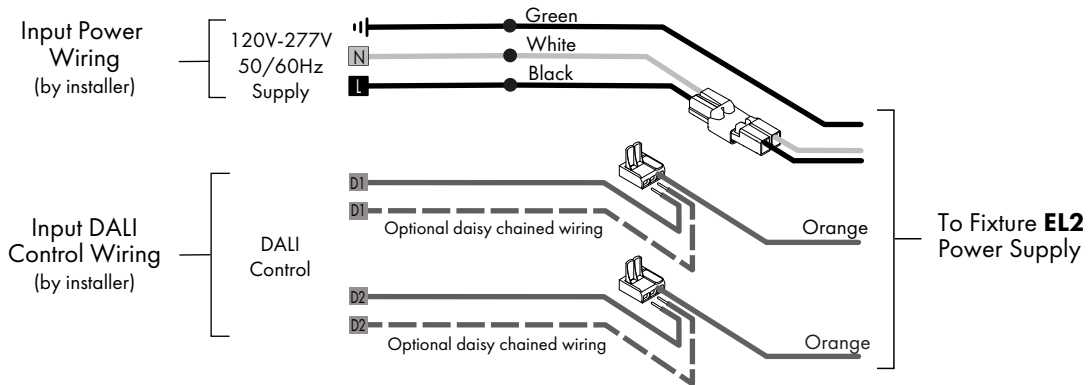

DALI Control Notes:

DALI control wiring is not polarity sensitive and can be run as Class 1 or 2. Up to 64 **EL2/EL2-01** power supplies can be daisy chained per DALI control loop. Maximum control wiring run length is 1000'.

For compatible dimmers for use with **EL2** drivers see: www.8lighting.com/resources-downloads.

FIG 14.1 Wiring Diagram

LU4 - LUTRON ECOSYSTEM CONTROL

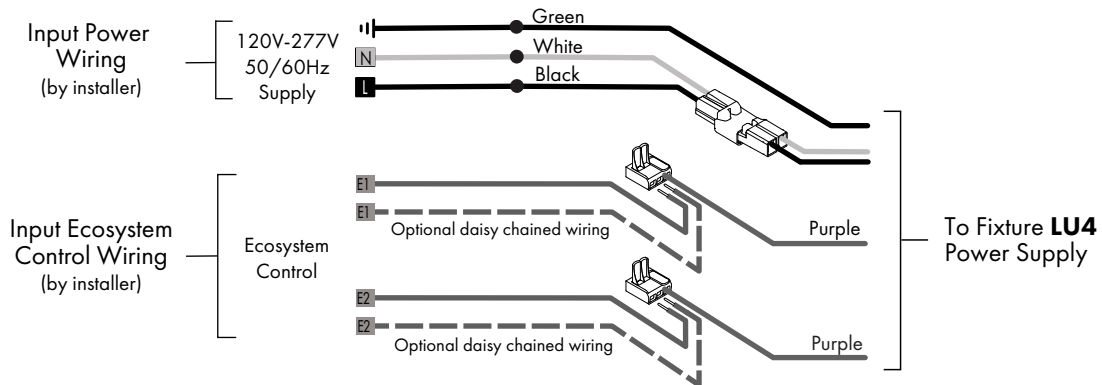

Lutron Ecosystem Control Notes:

Up to 64 **LU4** power supplies can be daisy chained per Ecosystem control loop. Maximum control wiring run length is 1000'.

For additional information, contact LED Center of Excellence at 1.877.346.5338 or LEDs@lutron.com

FIG 14.2 Wiring Diagram



www.8lighting.com

Number Eight Lighting Company

526 Portal Street, Cotati, CA 94931

Phone (707) 794-0888 • Email customerservice@8lighting.com