



INSTALLATION INSTRUCTIONS RECESSED MODEL SERIES 804D

WARNING: Read and understand these instructions completely before installation. Disconnect power at circuit breaker or fuse panel before installation. Always allow LED assembly to cool before servicing. To be installed by qualified electricians only. Products should be installed in accordance with these instructions, local electrical codes, and the National Electric Code (NEC). These products may represent a possible shock or fire hazard if improperly installed.

Do not install where insulation or ambient temperatures will exceed maximum values noted in product specifications. See www.8lighting.com for current product specifications.

NOTE: Number Eight Lighting fixtures are designed to meet the latest NEC requirements and are listed in full compliance with UL standards. Before attempting installation check your local electrical code which sets the wiring standards and installation requirements for your locality.

Save these instructions.

HOUSING INSTALLATION INSTRUCTIONS RECESSED MODEL SERIES 804D

Mounting Hanger Bars

STEP 1 Loosen 2 screws slightly on Housing to attach or adjust each Hanger Bar Bracket. Position Hanger Bar Bracket in hole position #1 & secure screws – **FIG 1.1 & 1.2.**

STEP 2 Assemble Hanger Bar A & B through each Hanger Bar Bracket to slide onto each other. The ends should have 1" minimum overlap.

Note: Hanger Bars can be shortened at break locations shown – **FIG 1.1.**

End Mounting

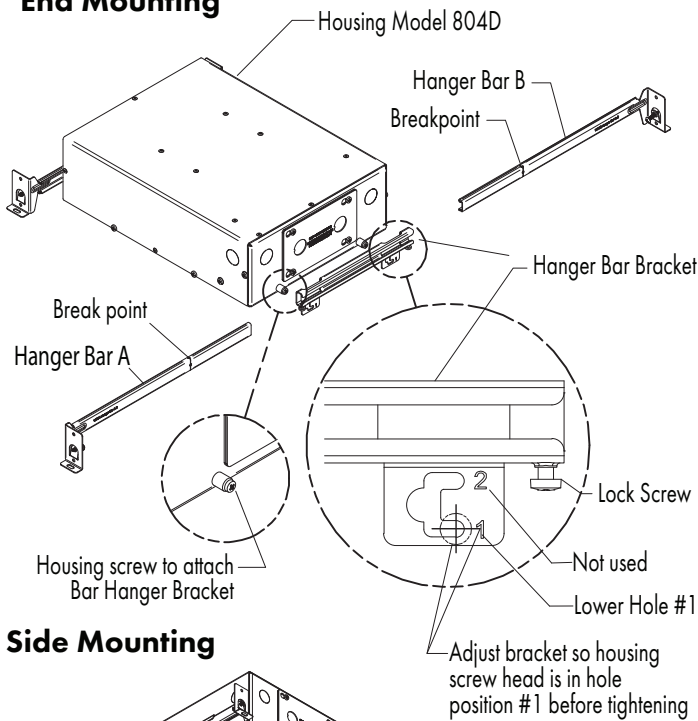

Side Mounting

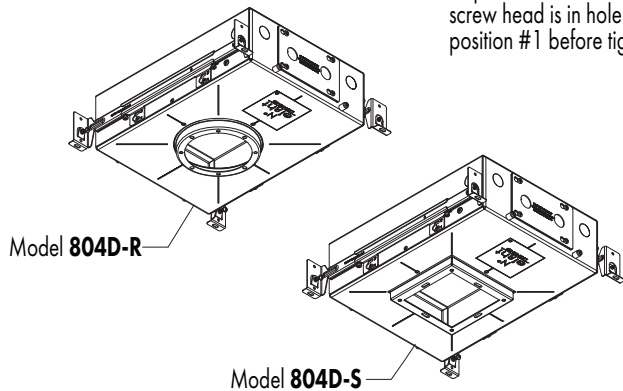

IMPORTANT:

Install so Hanger Bar flanges are positioned as shown

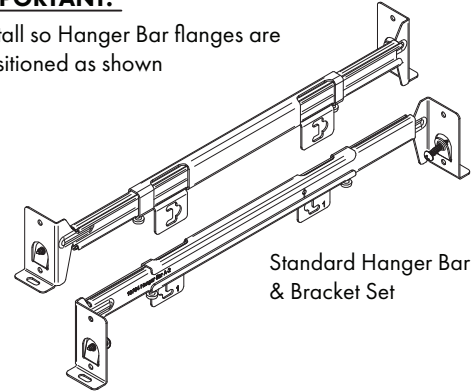

Hole Position Lower Hole #1

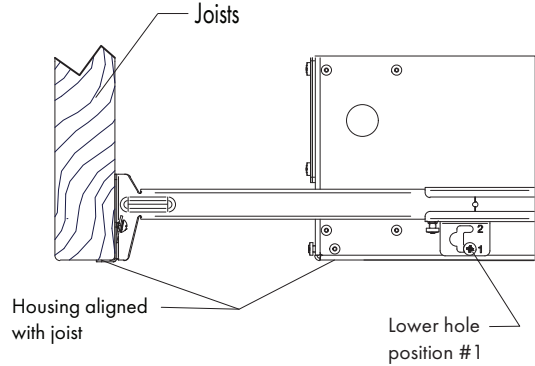

Caution: !

Be sure to select correct hole position for intended Trim assembly. Changing hole position is not possible after ceiling is installed.

FIG 1.1 Installing Hanger Bar & Hanger Bracket Set

FIG 1.2 Hole Position & Housing Location



CEILING CUTOUT CHART FOR PLASTER/SHEETROCK CEILINGS

STEP 4 For Plaster/sheetrock only-Accurately measure cutout location (for housing aperture center) & mark centers in ceiling board.

⚠ Important: Cutout location accuracy is critical, always double check measurements before cutting.

STEP 5 Cut openings in ceiling board as dimensioned below.

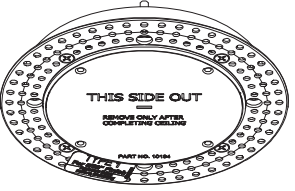
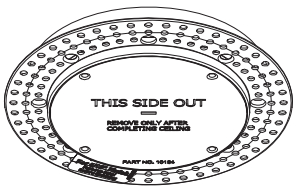
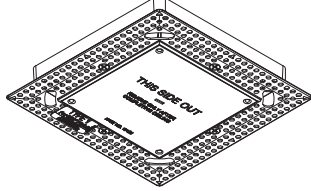
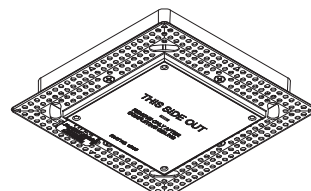
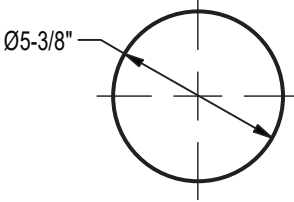
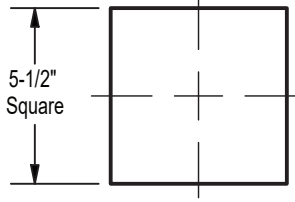
Round Trims		Square Trims			
Trim Model	 <p>FR-P-1</p>	 <p>FR-P-2</p>	 <p>FS-P-1</p>	 <p>FS-P-2</p>	
	Round Trim Cutout		Square Trim Cutout		
					
		<p>Tolerance: Round Trim Cutout $\pm 1/16$"</p>		<p>Tolerance: Square Trim Cutout $+1/16$"</p>	



HOUSING INSTALLATION INSTRUCTIONS

RECESSED MODEL SERIES 804D

Mounting Housing To Joists

- STEP 1 Spread Hanger Bars to approximate joist spacing. Temporarily secure Lock Screws to keep Housing from sliding along Hanger Bars – **FIG 5.1 & 5.2.**
- Note:** For Sloped Ceilings - Installing Housing so J Box Cover faces wall is recommended for maximum adjustment on applicable Lamp Modules – **FIG. 5.3.**
- STEP 2 Secure Housing & Hanger Bar assembly to Joists using either the fasteners supplied on Hanger Bars or fasteners through alternate mounting holes – **FIG 5.1.**
- STEP 3 Reposition Housing along Hanger Bars as needed. Use guide lines to help locate Housing relative to nearby walls or other fixtures – **FIG 5.1 & 5.2.**

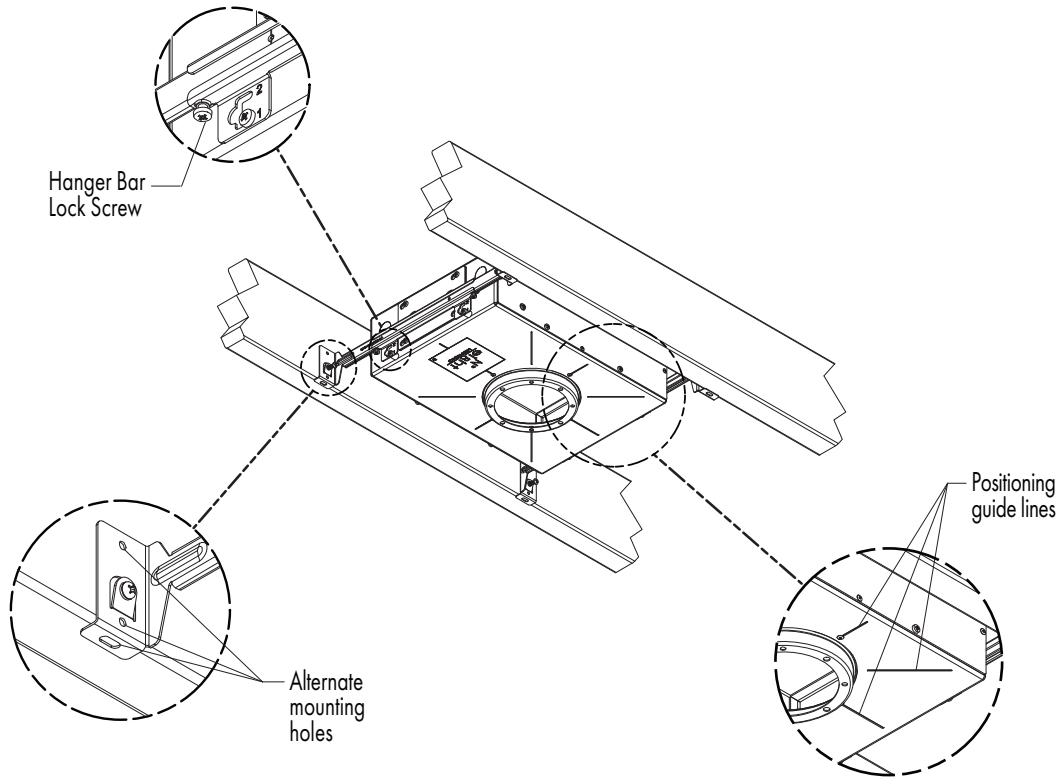

FIG 5.1 Fastening Housing to joists

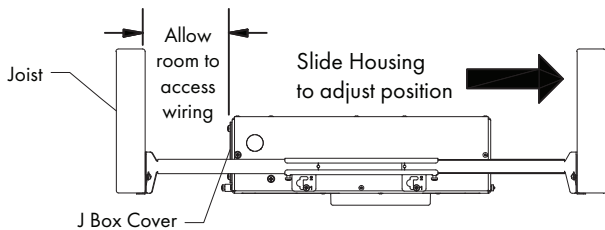

FIG 5.2 Horizontal Housing adjustment

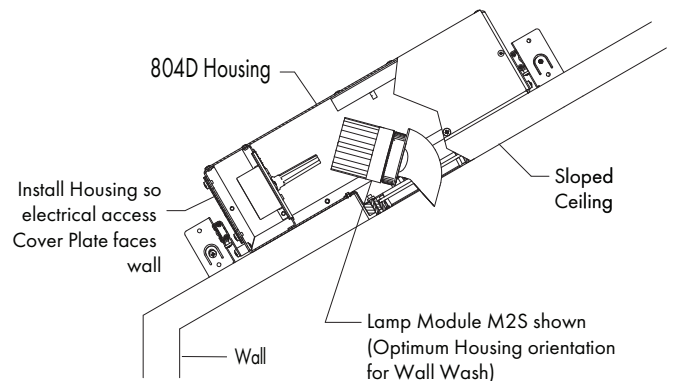
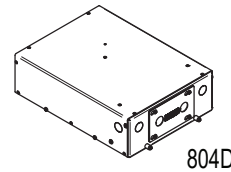

FIG 5.3 Recommended Sloped Ceiling Orientation

INSTALLATION INSTRUCTIONS

Model Series 804D

INSTALLING PANEL MOUNTING KIT



804D

CAUTION: Read all instructions completely before proceeding.

Important: Before attaching Panel Mounting Brackets you must determine Trim Model to be used (refer to Installation Instructions supplied with Housing or Trim Kit).

Note: Panel may consist of wood, stone or other structural material. Sheetrock could also be used attached below panel & must be considered part of the overall ceiling thickness.

Step 1 Install Trim Kit to Housing using instructions provided with Trim Kit.

Step 2 Locate & cut hole in ceiling panel (refer to hole size specified in Trim Installation Instructions supplied with Trim Kit) - **FIG 1**.

Step 3 Select upper or lower Bracket position (refer to Panel Mounting Bracket Position Table 1.1) & attach 2x Panel Mounting Brackets to Housing as shown using screws supplied with Housing (use side or end mounting locations as needed) - **FIG 1 & FIG 2**.

Step 4 Align Housing so Trim is visually centered in ceiling hole & secure Panel Mounting Brackets to panel using 4x Screws suitable for mounting surface (not supplied) - **FIG 1**.

Table 1.1 Panel Mounting Bracket Positioning Chart

Trim Models	For Ceiling Thickness Range	Hole Position #
FS-P, FR-P	1-1/8" to 1-1/2"	Lower #1

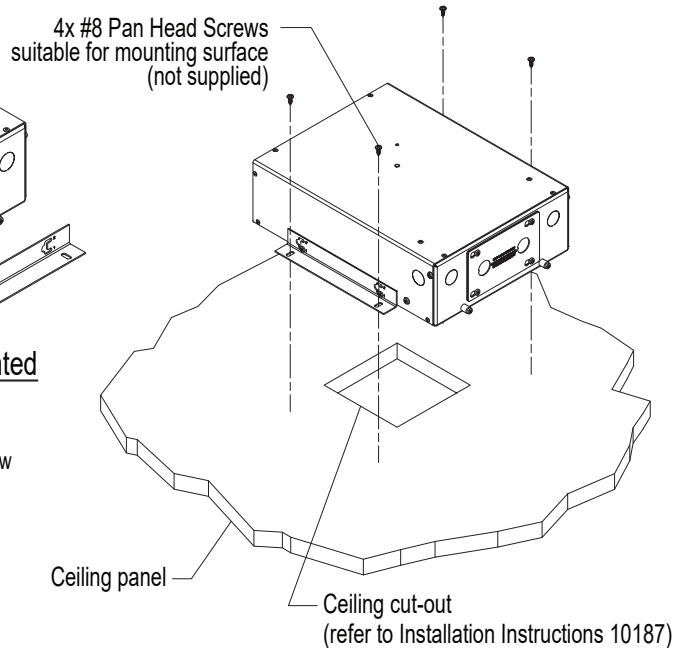
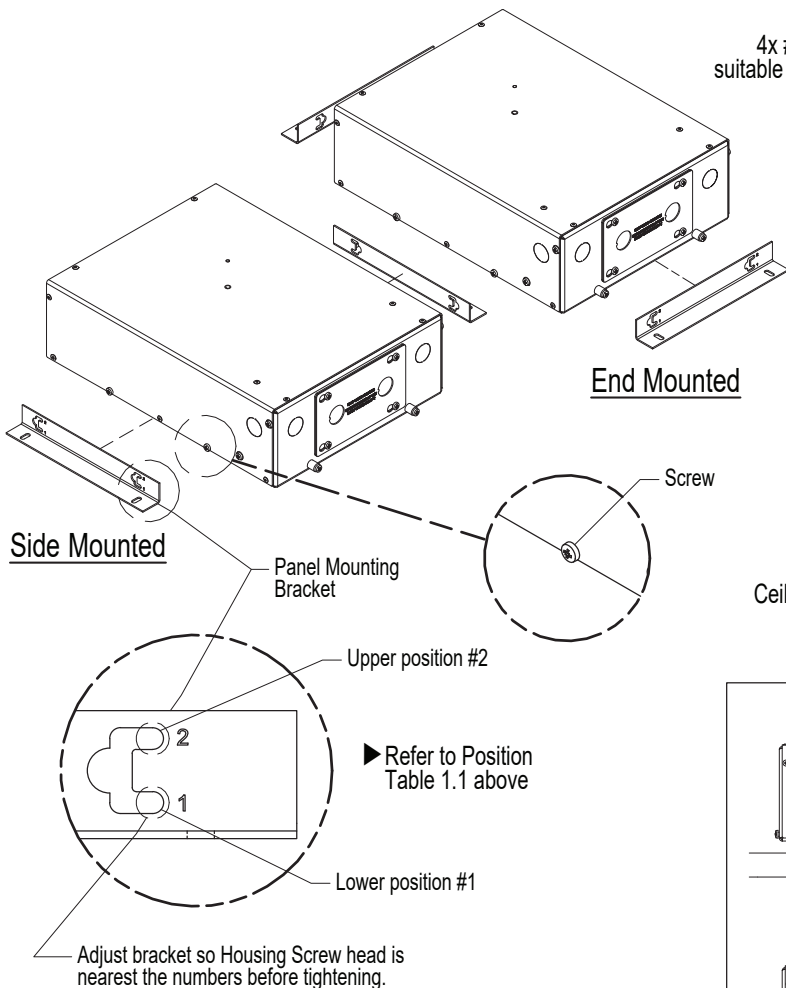

Caution

Be sure to select correct position for intended Trim assembly. Changing position may not be possible after ceiling is installed.

FIG 1 Install Panel Mounting Brackets (Model 804D Housing shown)

FIG 2 Hanger Bracket/Housing Position

INSTALLATION INSTRUCTIONS

Model Series 804 / 804S / 804D

T-GRID CEILING

Important: Determine Trim Kit type to be used & refer to **Hanger Bar Hole Position Table** in Housing or Trim Installation Instructions.

CAUTION: Hanger Bar Hole position cannot be changed after ceiling is installed.

STEP 1. Pre-assemble T-Grid Clips to Hanger Bars & tighten Hanger Bar Mounting Screws just enough to allow for vertical adjustment of Hanger Bracket - **Fig 1.**

STEP 2. Attach Hanger Bar Brackets to Housing in hole position 1 or 2 to accommodate Trim & ceiling tile thickness - **Fig. 2.**

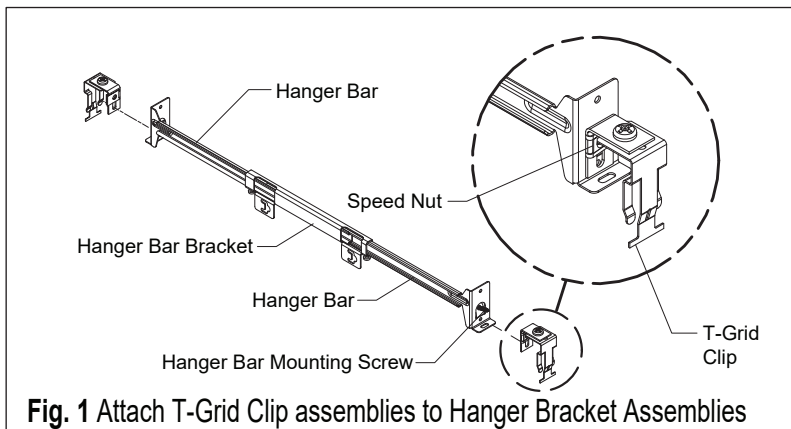

Fig. 1 Attach T-Grid Clip assemblies to Hanger Bracket Assemblies

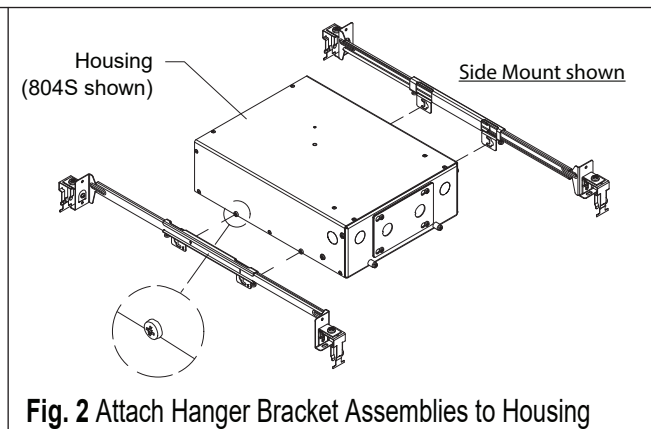

Fig. 2 Attach Hanger Bracket Assemblies to Housing

STEP 3. Extend Hanger bars to position T-Grid Clip assemblies fixture onto T-Grid bars - **Fig 3.4.**

Determine cut-out location in Ceiling Tile and ensure sufficient clearance for housing installation.

STEP 4. Cut opening in ceiling tile for Trim. For cut-out size, refer to Installation Instructions referenced above. Install Ceiling Tile into T-Grid - **Fig 4.5.**

Attach fixture to T-Grid so Trim fits into Ceiling Tile opening. Adjust fixture's horizontal position & lock into place by tightening the Hanger Bar Lock Screws - **Fig. 5.**

STEP 6. Adjust vertical height of Housing by sliding speed nuts so Housing is level with Ceiling Tile. Lock position by tightening Mounting Screws - **Fig 5.**

Note: Trim will permit a vertical adjustment range to help accommodate Ceiling Tile thickness.

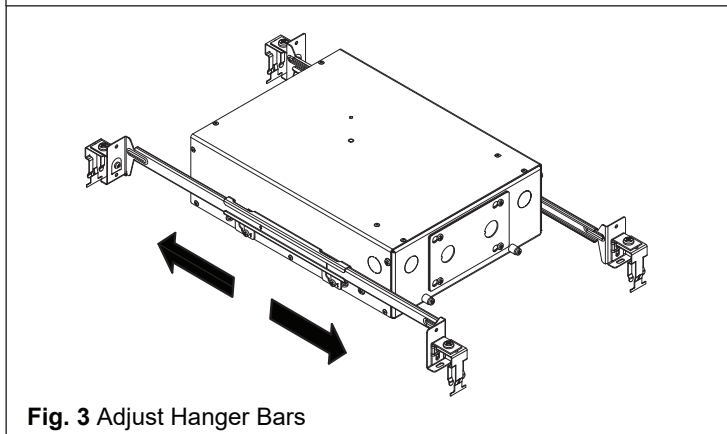

Fig. 3 Adjust Hanger Bars

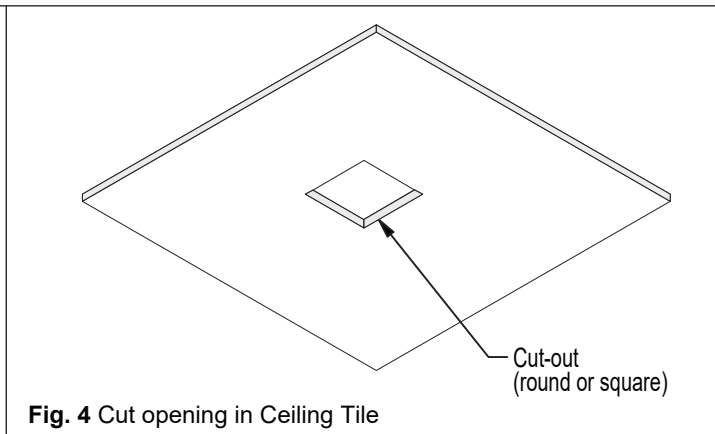

Fig. 4 Cut opening in Ceiling Tile

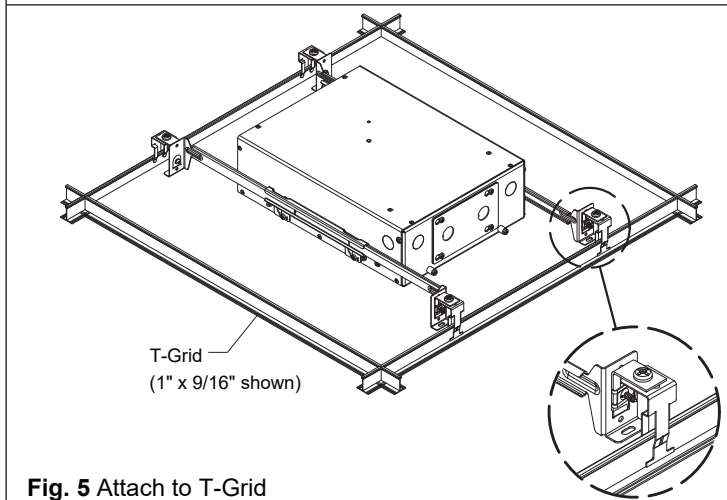

Fig. 5 Attach to T-Grid

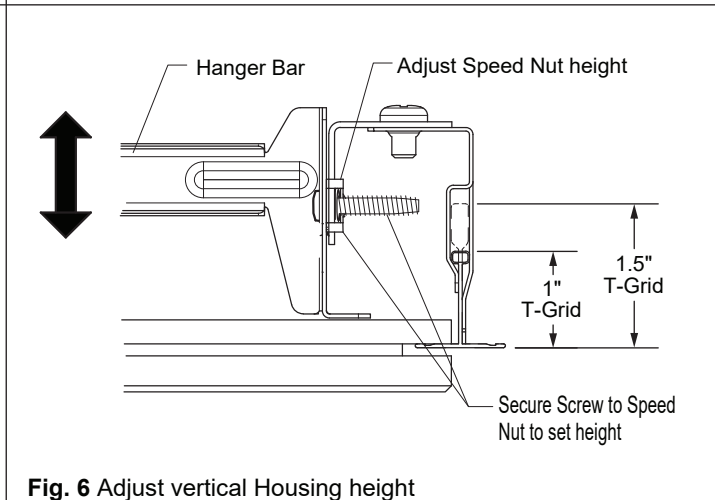

Fig. 6 Adjust vertical Housing height



INSTALLATION INSTRUCTIONS

Model Series 804 / 804S / 804D

Butterfly Bracket for Commercial C-channel or Bar Mounting

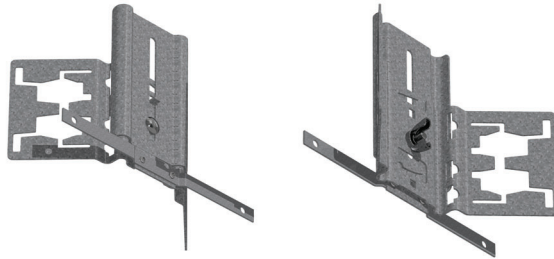

BB BUTTERFLY BRACKET (Set of 2)

STEP 1. Attach Butterfly Brackets to either ends or sides of mounting frame.

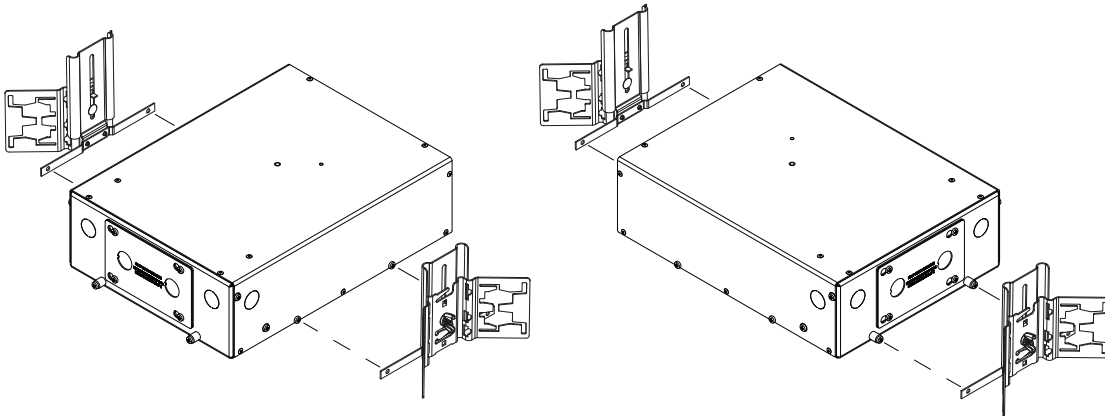

STEP 2. Slide c-channel or bar through bracket and adjust height with thumb screw.

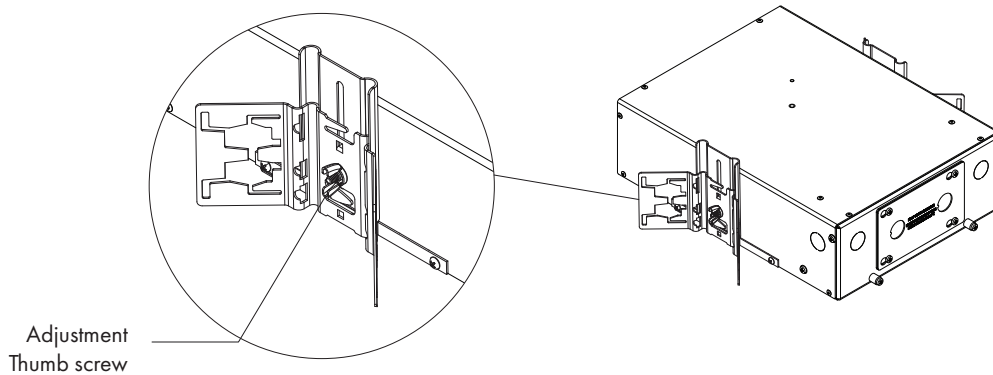



LED Lamp Module Instructions

MODEL SERIES 804 / 804S / 804D

Lamp Module J2 & J2S Installation / Adjustment / Removal

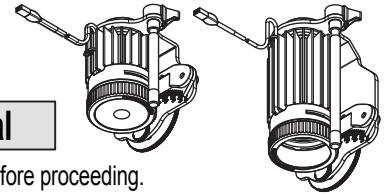

CAUTION: ▶ Turn off power at wall switch & review all instructions on this page before proceeding.
▶ Always allow lamp module to cool before servicing.

Installation (not required if pre-installed into housing):

Step 1 Before installing Lamp Module, make sure correct LED Power Supply Module is installed & Lock Shaft is in unlocked position - FIG 1.1.

Step 2 Insert Lamp Module into housing as shown then adjust to 45° position to expose Fastener. Secure to Housing Center Nut or Stud - FIG 1.2 & 1.3.

Step 4 Plug Wire Connector from Lamp Module into Power Supply Module connector. Push wire up inside housing to avoid interference during adjustment - FIG 1.2.

Adjustment: Adjust desired horizontal position & vertical aiming angle as shown in FIG 1.4.

Removal: To remove lamp module follow steps above in reverse order.

Replacement: Contact Number Eight Lighting for replacement Lamp Module.

Optional Accessories: Unscrew Lamp Ring to add/ remove accessories - FIG 1.2.

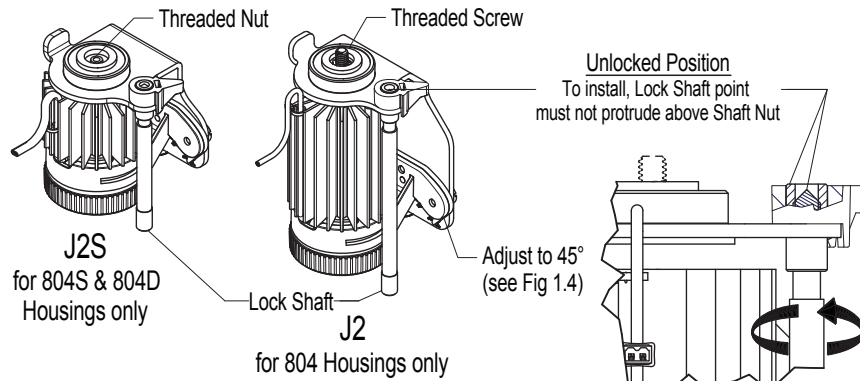
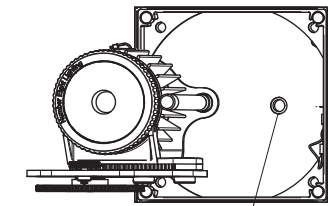
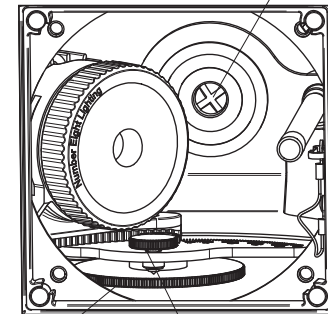

FIG. 1.1 Preparing Lamp Module J2 & J2S for installation



Tighten Lamp Module Fastener to Housing Center Nut or Stud



To expose lamp module fastener, adjust vertical axis angle to 45 deg using Gear Knob (See Fig 1.4)

FIG. 1.3 Securing Lamp Module to Housing

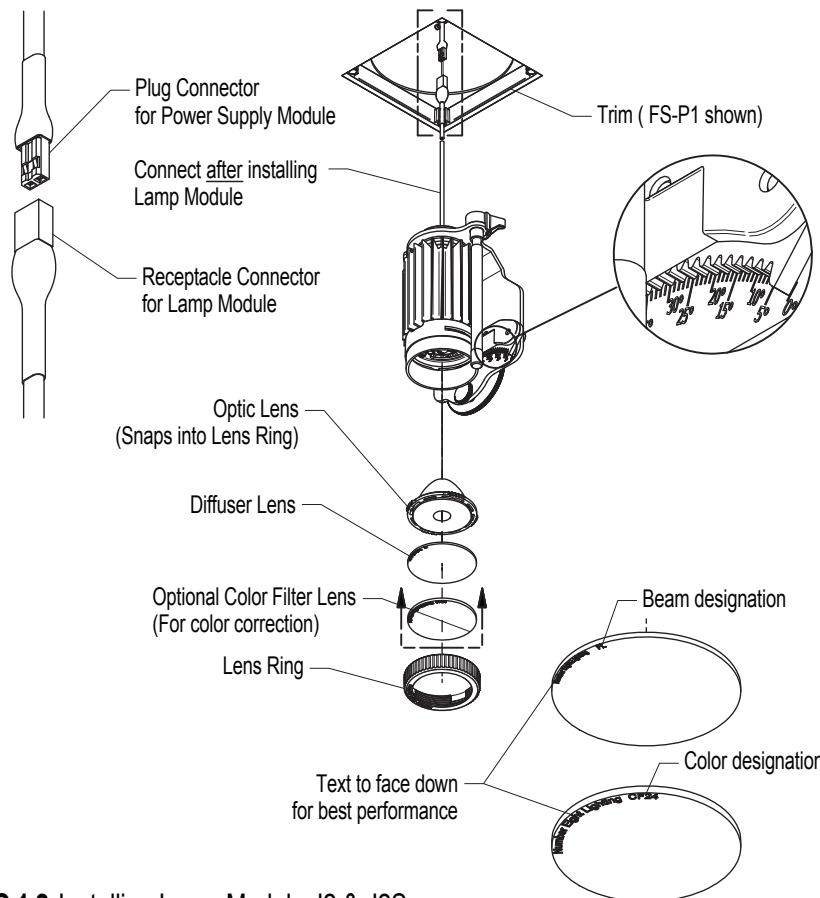

FIG. 1.2 Installing Lamp Module J2 & J2S

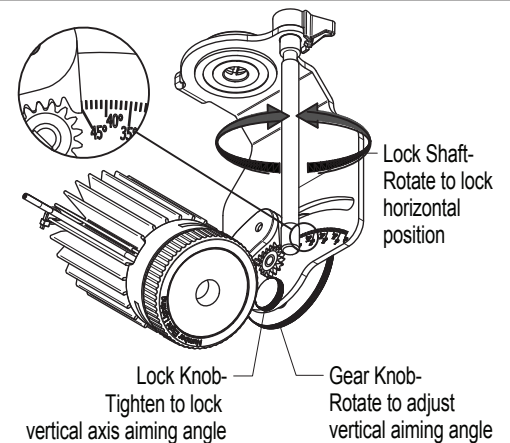
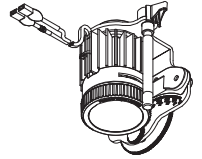

FIG. 1.4 Aiming Adjustment

Lamp Module J2S-TW Installation/Adjustment/Removal Instructions

MODEL SERIES 804D

CAUTION: ▶ Turn off power at wall switch & review all instructions on this page before proceeding.
▶ Always allow lamp module to cool before servicing.



Installation (not required if pre-installed into housing):

Step 1 Before installing Lamp Module, make sure accessories & correct LED Power Supply Module are installed & Lock Shaft is in unlocked position - FIG 1.1 & 1.2.

Step 2 Insert Lamp Module into housing as shown then adjust to 45° position to expose fastener. Secure to Housing Center Stud - FIG 1.2 & 1.3.

Step 4 Plug Wire Connectors from Lamp Module into Power Supply Module connectors. Push wires up inside housing to avoid interference during adjustment - FIG 1.2.

Adjustment: Adjust desired horizontal position & vertical aiming angle as shown in FIG 1.4.

Removal: To remove lamp module follow steps above in reverse order.

Replacement: Contact Number Eight Lighting for replacement Lamp Module.

Optional Accessories: Unscrew Lamp Ring to add/ remove accessories - FIG 1.2.

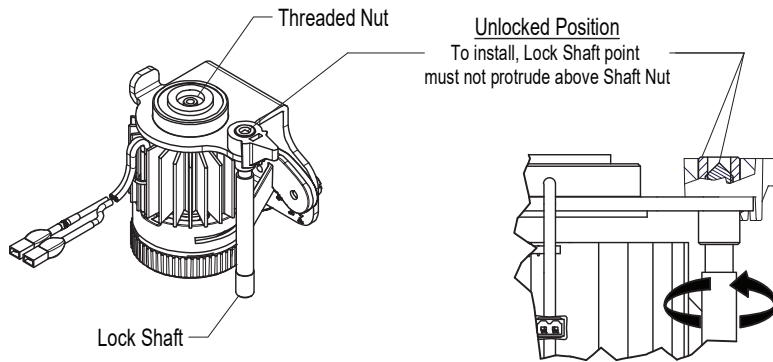
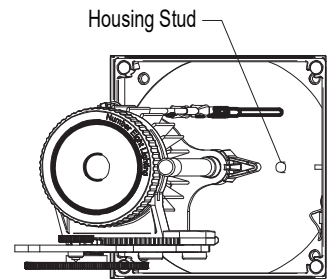
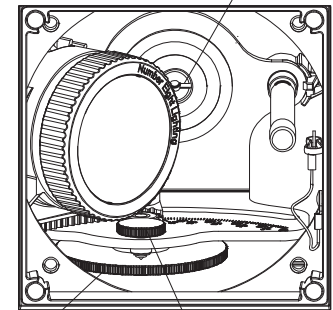

FIG. 1.1 Preparing Lamp Module J2S -TW for installation



Tighten Lamp Module Fastener to Housing Stud



To expose lamp module fastener, adjust vertical axis angle to 45 deg using Gear Knob (See Fig 1.4)

FIG. 1.3 Securing Lamp Module to Housing

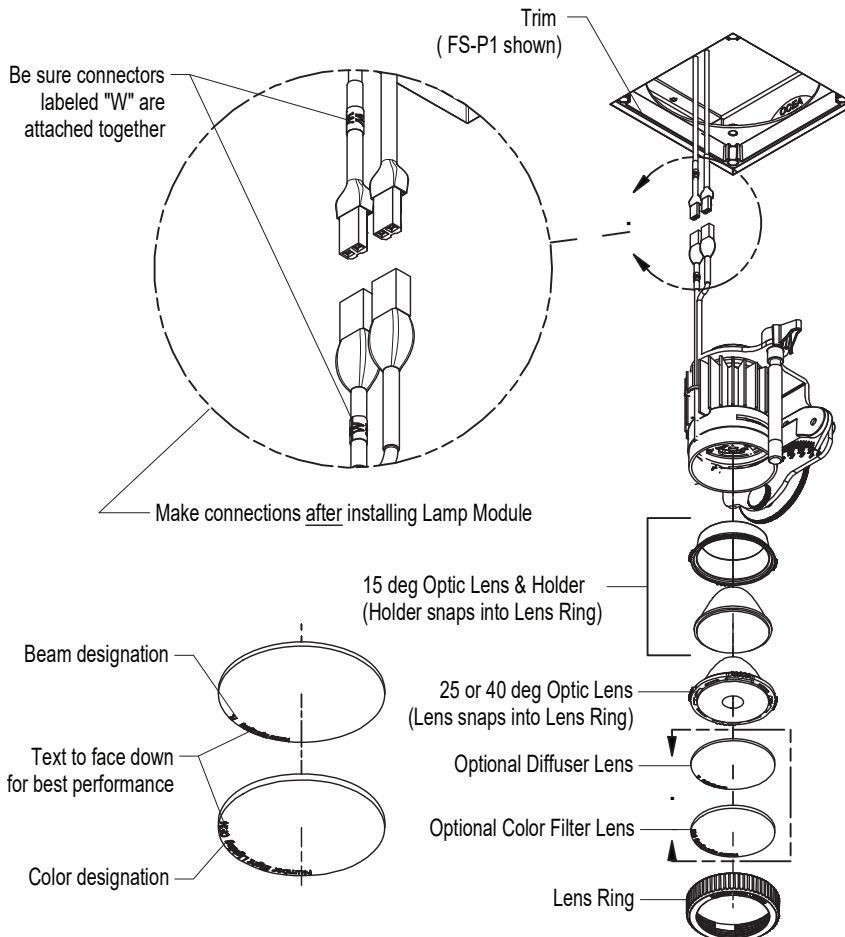

FIG 1.2 Installing Lamp Module J2S-TW

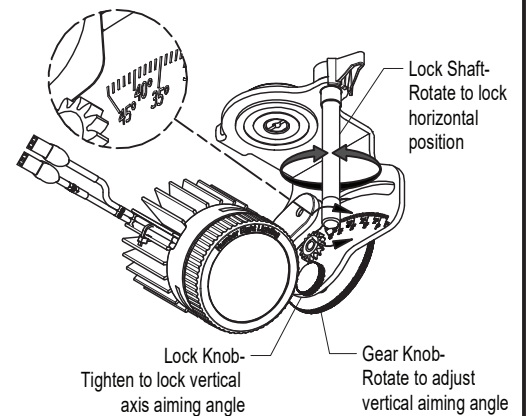

FIG 1.4 Aiming Adjustment



Lamp Module K2 & K2S -Installation/Removal

MODEL SERIES 804 / 804S / 804D

CAUTION:

- ▶ Turn off power at wall switch & review all instructions on this page before proceeding.
- ▶ Always allow lamp module to cool before servicing.

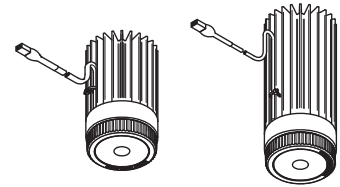

Installation (not required if pre-installed into housing):

Step 1 Before installing Lamp Module, make sure the LED Power Supply Module is installed (shown on page 5).

Step 2 Pull Power Module Connector through opening & insert Lamp Module into housing as shown. Secure Lamp Module to Housing Nut or Stud & hand tighten - Fig 2.1 & 2.2.

Step 3 Plug Wire Connector from Lamp Module into Power Supply Module connector. Push wire up inside housing to avoid interference with LED - Fig 2.2.

Removal: To remove lamp module follow steps above in reverse order.

Replacement: Contact Number Eight Lighting for replacement Lamp Module.

Optional Accessories: Unscrew Lamp Ring to add/remove accessories- Fig 2.1.

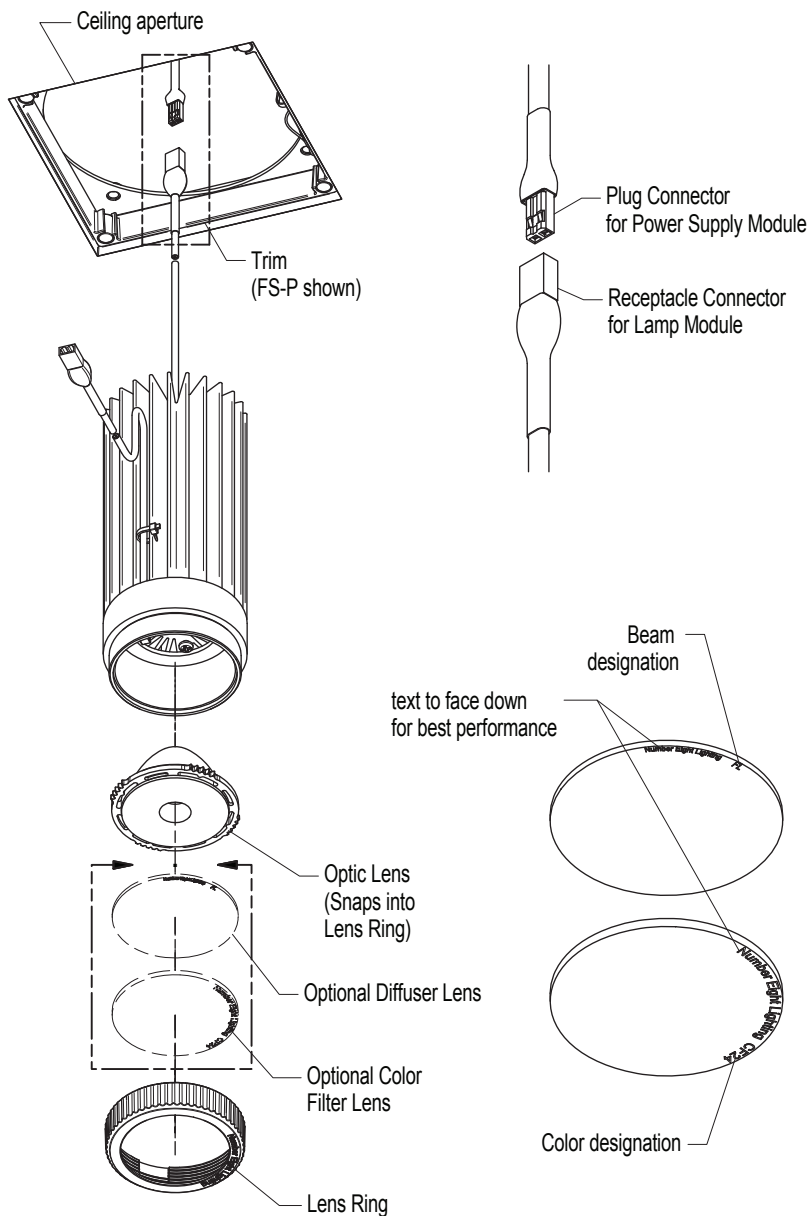
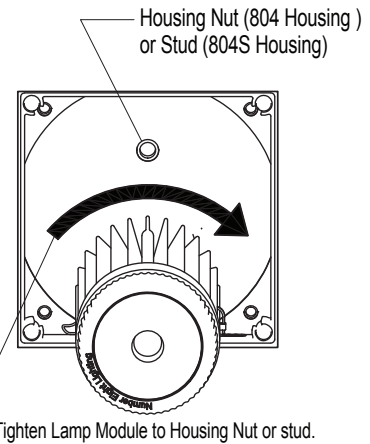
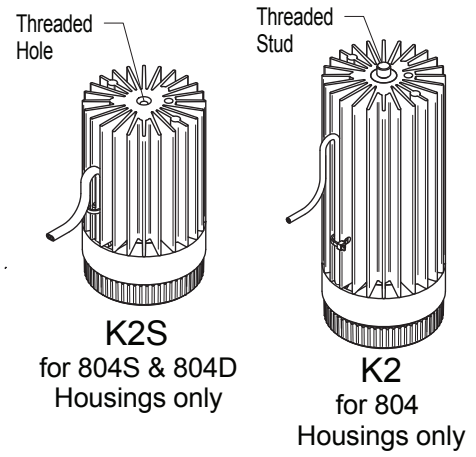

FIG 2.1 Installing Lamp Module K2 / K2S & Accessories



!
Note: If LED fails to light check if connectors are plugged together as shown.

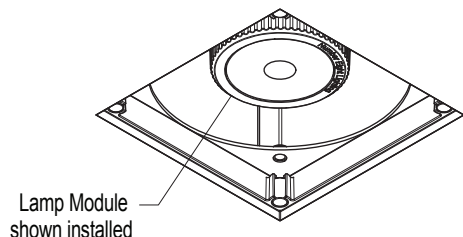

FIG. 2.2 Securing Lamp Module K2 & K2S to Housing

Lamp Module M2 & M2S Installation / Adjustment / Removal

MODEL SERIES 804 / 804S / 804D

CAUTION: 

- ▶ Turn off power at wall switch & review all instructions on this page before proceeding.
- ▶ Always allow lamp module to cool before servicing.

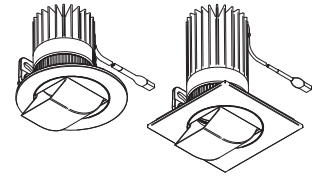

Installation:

Step 1 Before installing Lamp Module M2 or M2S, make sure LED Power Supply Module is installed (shown on page 9).

Note: For use of M2 & M2S with Sloped Ceilings Only-See recommended Housing installation orientation - FIG 4.1

Step 2 Adjust vertical to 90° position as shown in Fig. 4.3. Note: angle adjustment is limited on ceilings over 5/8" thick & when Mirror Reflector is aligned facing narrow sides of Housing.

Step 3 Plug Wire Connector from Lamp Module into Power Supply Module Connector. Push wire up inside Housing to avoid interference during installation - Fig 4.4.

Step 4 Choose general aiming position desired. Attach Safety Cable from Trim Cable Clip to Lamp Module before inserting Lamp Module into Housing aperture. Seat Trim Plate into Trim.

Note: horizontal & vertical aiming position adjustment is lockable using Lock Knobs. General aiming position is easily changed by pulling Lamp Module out slightly & rotating into one of 4 positions - Fig 4.2 & 4.3.

Removal: To remove Lamp Module follow steps above in reverse order.

Replacement: Contact Number Eight Lighting for replacement LED Engine Subassy. Remove Lamp Module & unscrew LED Engine Subassy for replacement.

Optional Accessories: Unscrew LED Engine Subassy to add/remove Lens accessories - Fig 4.2.

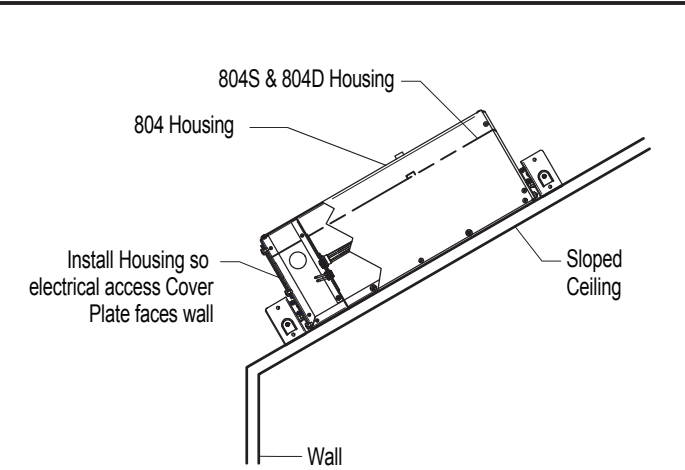

FIG 4.1 Recommended Housing Orientation for Sloped Ceiling

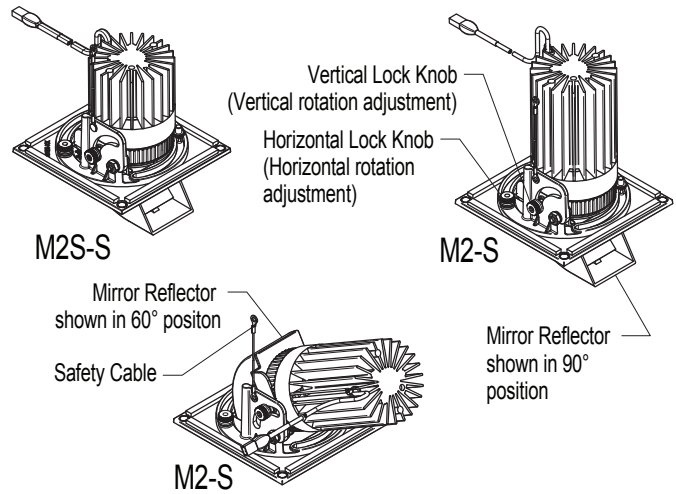

FIG. 4.3 Lamp Module Adjustment

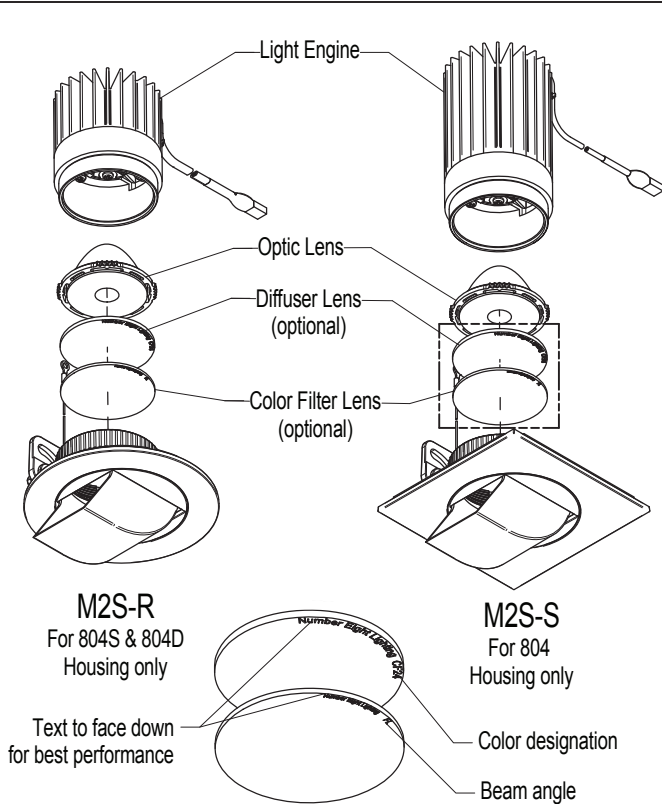
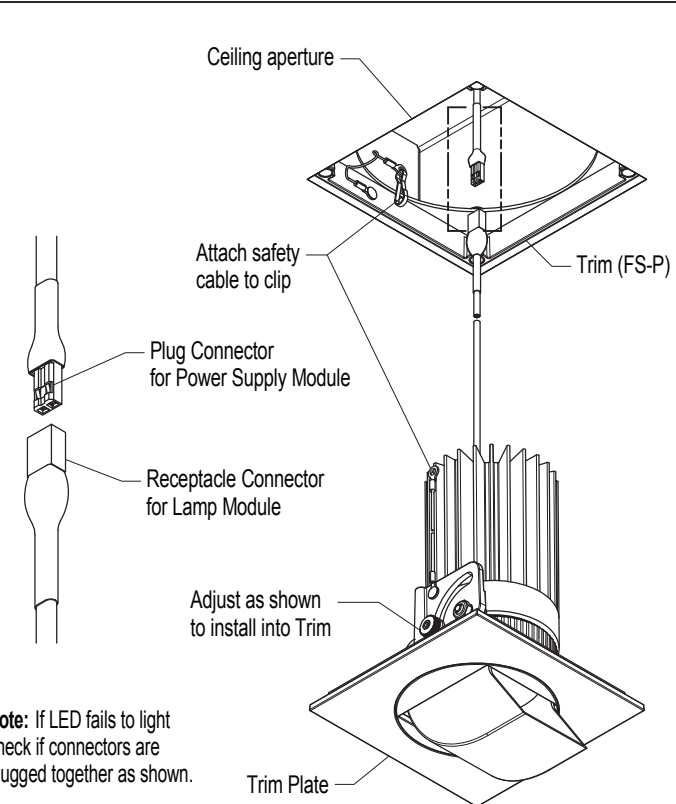

FIG 4.2 Installing Lamp Module Accessories



Note: If LED fails to light check if connectors are plugged together as shown.

FIG. 4.4 Securing Lamp Module to Housing & Trim

LED Power Supply Module Removal / Replacement

MODEL SERIES 804 / 804S / 804D

CAUTION: ⚠️

- ▶ Disconnect power at circuit breaker or fuse panel before proceeding.
- ▶ Always allow Lamp & Power Supply Module to cool before removing.

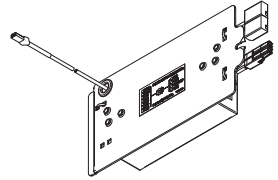

To remove LED Power Supply Modules

Step 1 To access Power Supply Module the Lamp Module must first be removed (For Lamp Modules refer to Pages 1-4).

Step 2 Unscrew & remove Thumb Knob inside Housing as shown. Tilt Power Supply Module to disengage offset tab from housing as shown-FIG 5.1.

Step 3 Pull Power Supply Module away from threaded stud and pull wires & Power Connectors out of the Junction Box-FIG 5.2.

Step 4 Disconnect Power Supply Connectors. For models with 0-10 drivers, also disconnect purple & gray wires-FIG 5.2.

Step 5 Pull Power Supply Module through aperture-FIG 5.3.

For Replacement: Replace all parts in steps above in reverse order. Push all wires into wiring compartment & replace Power Supply Module as shown in FIG 5.4.

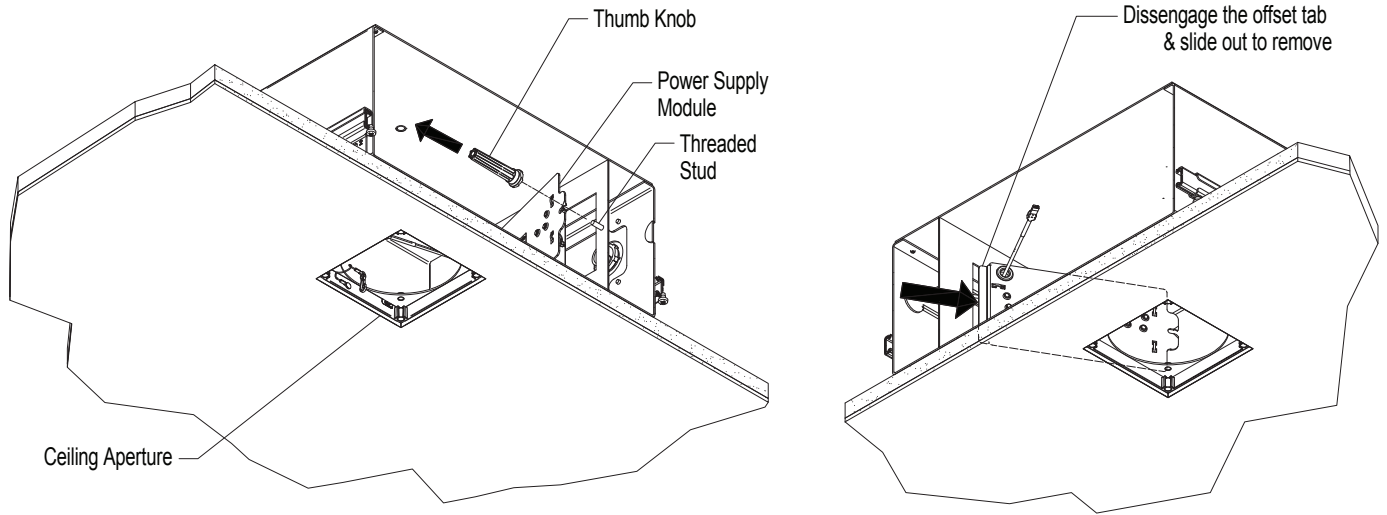

FIG 5.1 Remove Thumb Knob & Disengage Power Supply Module (Model 804 shown)

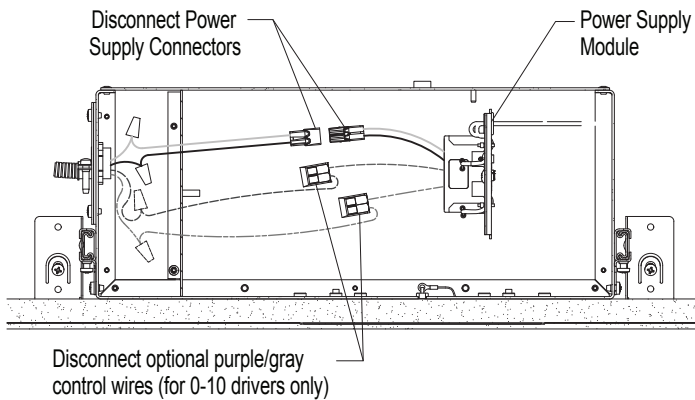

FIG 5.2 Remove Power Supply Module & disconnect wires

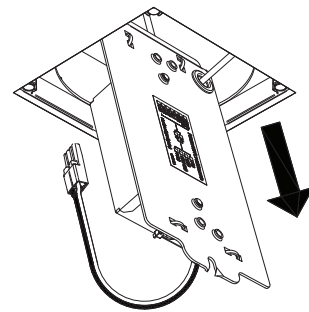
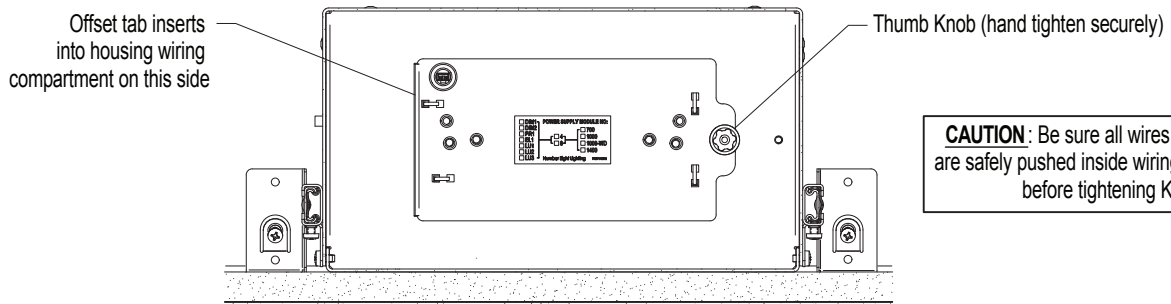

FIG 5.3 Pass Power Supply Module Through Aperture



CAUTION: Be sure all wires & connectors are safely pushed inside wiring compartment before tightening Knob.

FIG 5.4 Replace Power Supply Module & Secure With Thumb Knob (Model 804 Housing shown)

WIRING INSTRUCTIONS - 804D

For DIM1 / DIM2 / PR1 / EL1 / EL2 / LU1 / LU2 / LU4 Dimming Options

CAUTION: TO AVOID RISK OF FIRE OR ELECTRIC SHOCK

Turn off power at circuit breaker or fuse panel & read instructions completely before proceeding.

Failure to follow instructions may void warranty. Save these instructions.

- Installation must be by a qualified electrician only and must conform to National Electric code and local regulations.
- Verify correct dimming system, lamp module, power supply type, and input supply requirements.
- Always allow LED assembly to cool before servicing.
- Do not install where insulation or ambient temperatures will exceed maximum values noted in product specifications. See www.8lighting.com for current product specifications.
- For multi-lamp refer to lighting plan to determine lamp circuit control configuration.

804D Wiring

DIM1 / PR1 / LU1 - PHASE CONTROL

1. Loosen screws to remove cover plate & connect driver output wires using electrical connectors at wiring compartment – FIG 1.2.
2. Remove required knockouts in cover plate or housing & secure suitable electrical connectors into knock outs for supply wires – FIG 1.2.
3. Make wire connections & push all wires & connections completely inside wiring compartment – FIG 1.1 & 1.2.
4. Replace & secure box cover plate using screws provided – FIG 1.2.

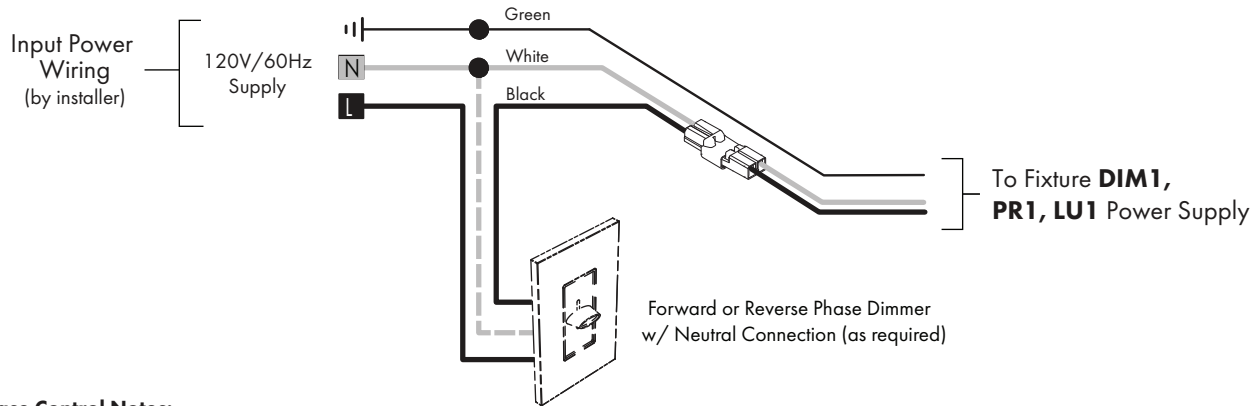

Phase Control Notes:

DIM1 / PR1 drivers are Forward or Reverse Phase dimmable.

For compatible dimmers for use with **DIM1 / PR1** drivers see: www.8lighting.com/resources-downloads

LU1 drivers are Forward Phase dimmable only.

For compatible dimmers for use with **LU1** drivers, contact Lutron LED Center of Excellence at 1.877.346.5338 or LEDs@lutron.com

FIG 1.1 Wiring Diagram

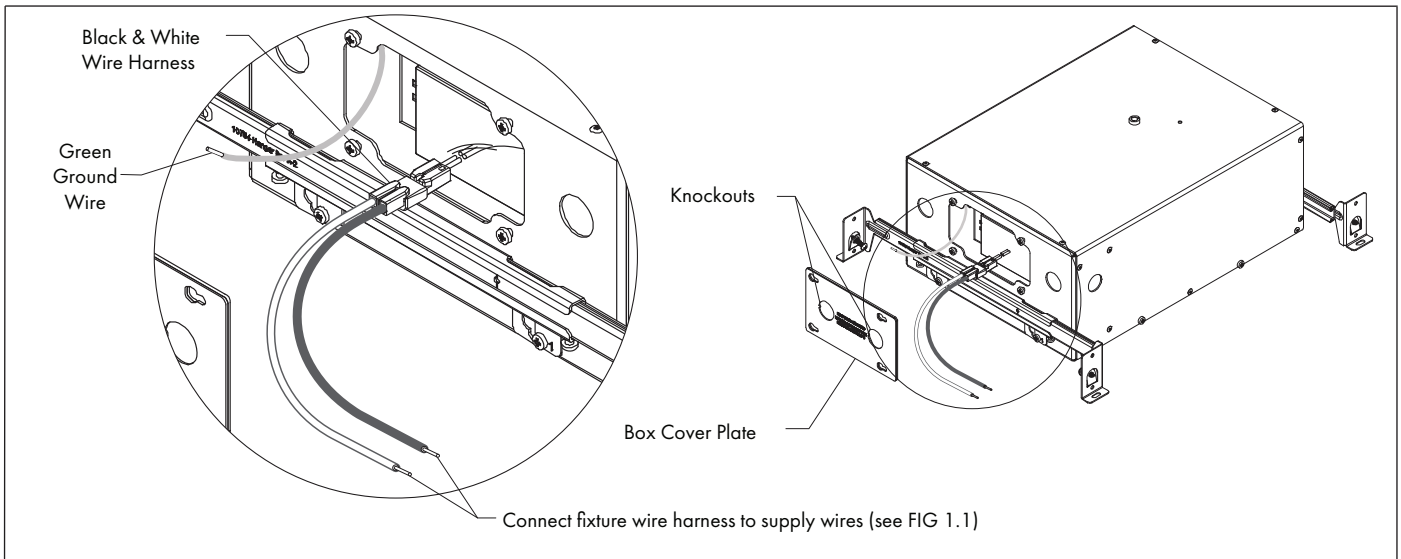

NOTE: For compatible dimmers for use with **DIM1 / PR1** drivers see www.8lighting.com/resources-downloads/

For compatible dimmers for use with **LU1** drivers, contact Lutron customer assistance at 1.877.346.5338 or LEDs@lutron.com

FIG 1.2 Wire Connections

804D Wiring

DIM2 / EL1 - 0-10V CONTROL

1. Loosen screws to remove cover plate & connect driver output wires using electrical connectors at wiring compartment – FIG 2.2.
2. Remove required knockouts in cover plate or housing & secure suitable electrical connectors into knock outs for supply wires – FIG 2.2.
3. Make wire connections & push all wires & connections completely inside wiring compartment – FIG 2.1 & 2.2.
4. Replace & secure box cover plate using screws provided – FIG 2.2.

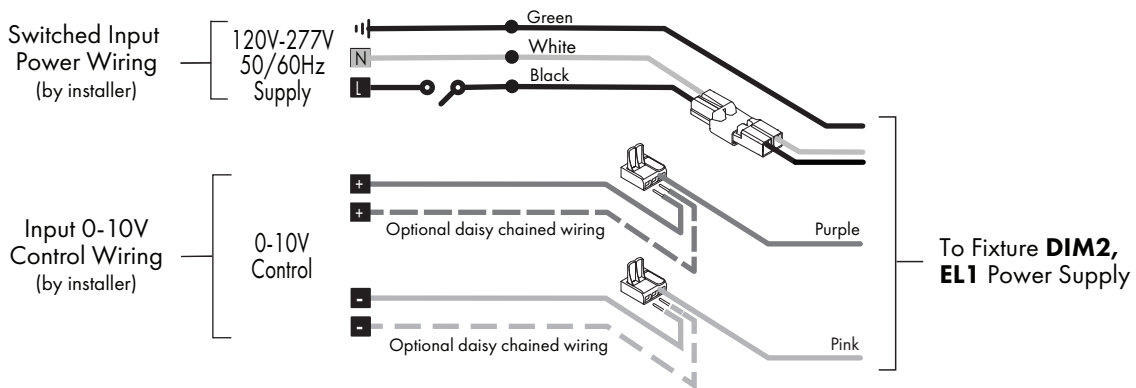

0-10V Control Notes:

0-10V control wiring is polarity sensitive and should be run as Class 2.

300' is the maximum control wiring run length to reduce EMI susceptibility and voltage drop. Voltage drop should be no greater than 0.3V.

For compatible dimmers for use with DIM2 /EL1 drivers see: www.8lighting.com/resources-downloads.

FIG 2.1 Wiring Diagram

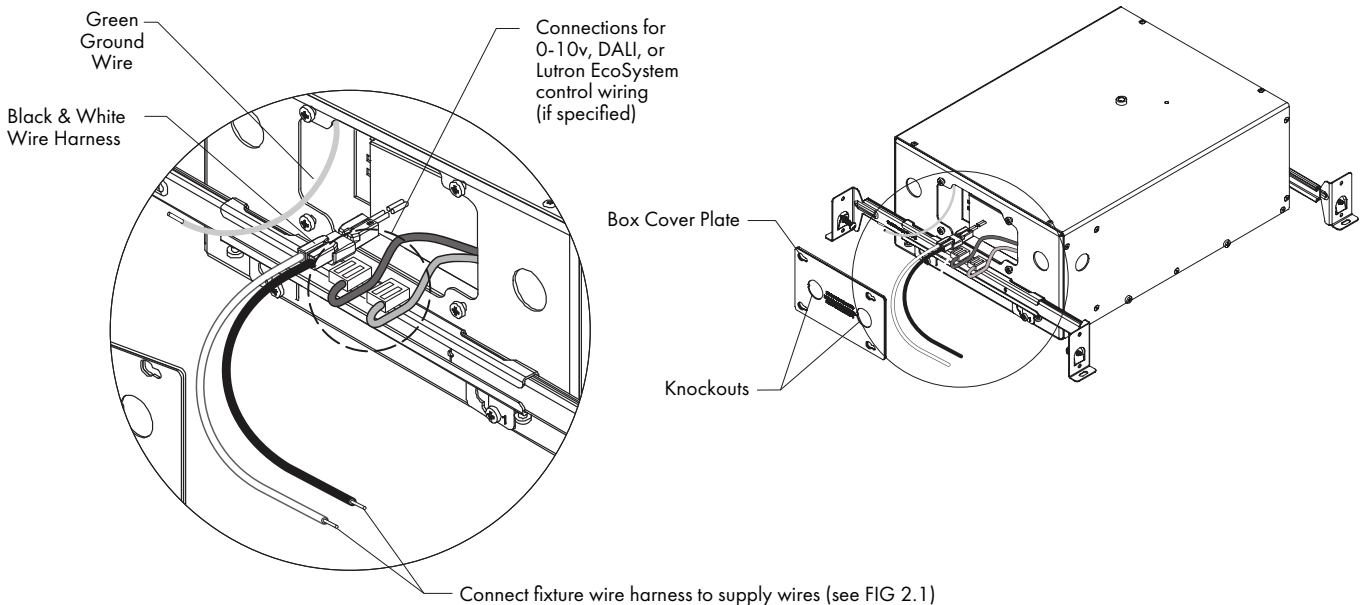

FIG 2.2 Wire Connections

WIRING INSTRUCTIONS (Continued)

804D Wiring

EL2 - DALI CONTROL

1. Loosen screws to remove cover plate & connect driver output wires using electrical connectors at wiring compartment – FIG 3.2.
2. Remove required knockouts in cover plate or housing & secure suitable electrical connectors into knock outs for supply wires – FIG 3.2.
3. Make wire connections & push all wires & connections completely inside wiring compartment – FIG 3.1 & 3.2.
4. Replace & secure box cover plate using screws provided – FIG 3.2.

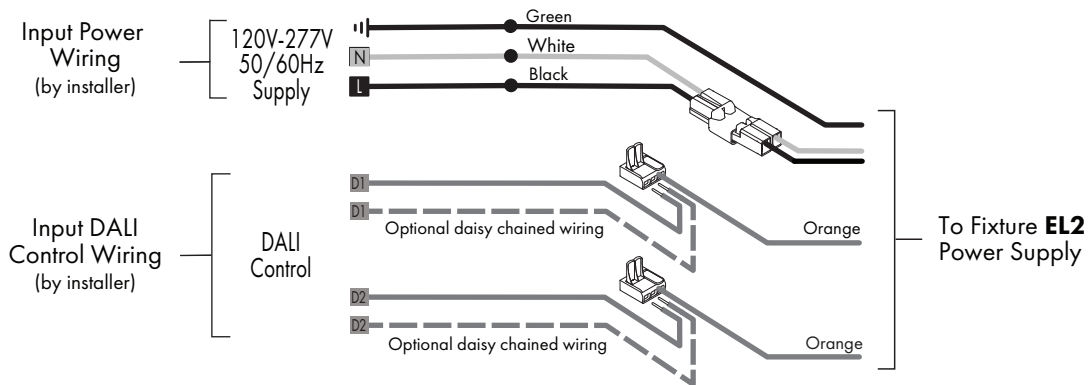

DALI Control Notes:

DALI control wiring is not polarity sensitive and can be run as Class 1 or 2. Up to 64 EL2 power supplies can be daisy chained per DALI control loop. Maximum control wiring run length is 1000'.

For compatible dimmers for use with EL2 drivers see: www.8lighting.com/resources-downloads.

FIG 3.1 Wiring Diagram

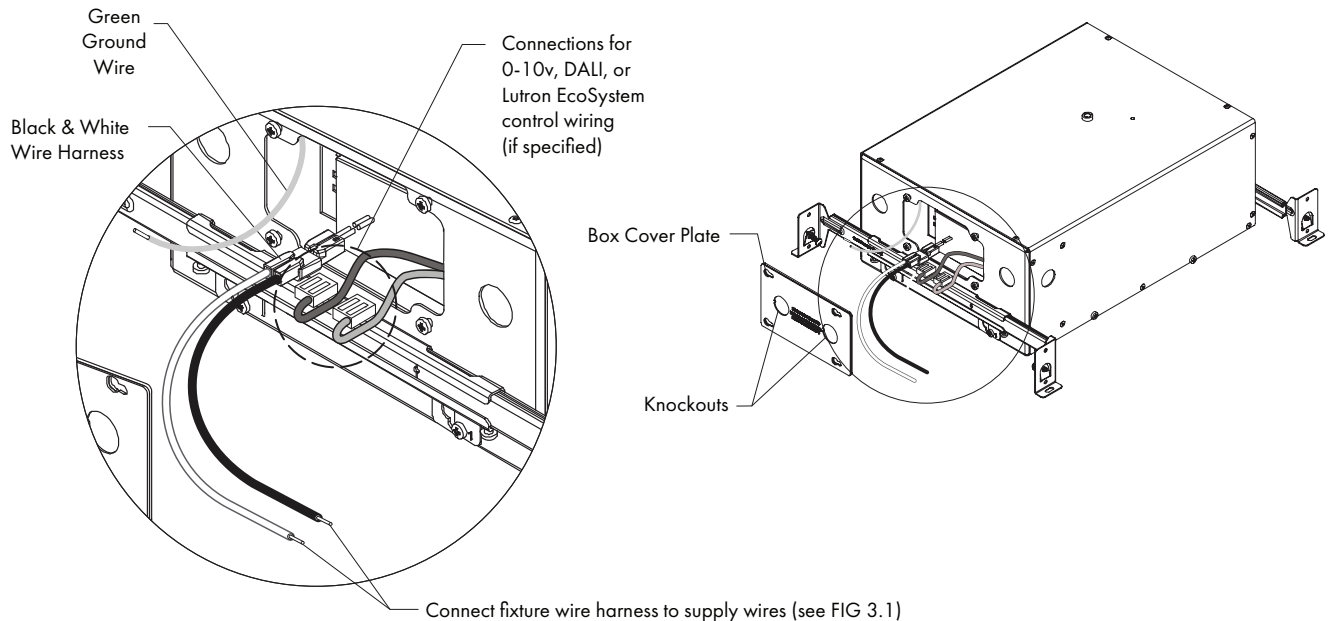
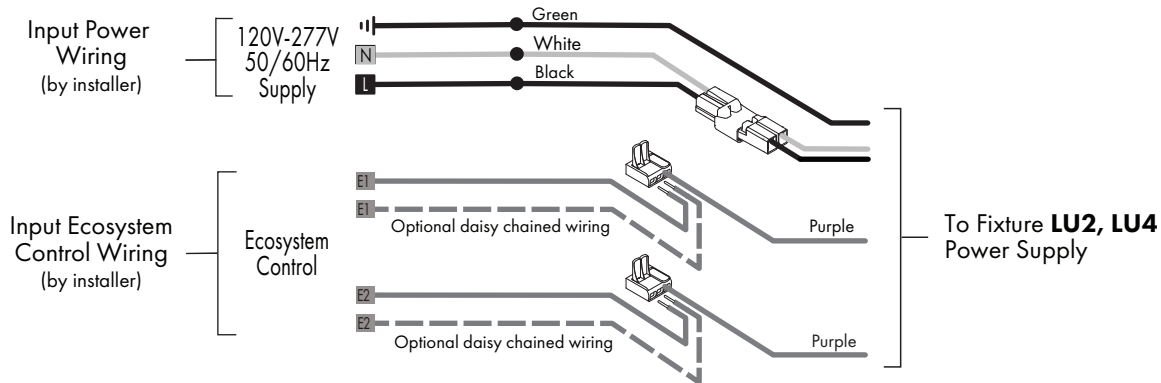

FIG 3.2 Wire Connections

804D Wiring

LU2 / LU4 - LUTRON ECOSYSTEM CONTROL

1. Loosen screws to remove cover plate & connect driver output wires using electrical connectors at wiring compartment – FIG 4.2.
2. Remove required knockouts in cover plate or housing & secure suitable electrical connectors into knock outs for supply wires – FIG 4.2.
3. Make wire connections & push all wires & connections completely inside wiring compartment – FIG 5.1 & 5.2.
4. Replace & secure box cover plate using screws provided – FIG 5.1.



Lutron Ecosystem Control Notes:

Up to 64 LU2 / LU4 power supplies can be daisy chained per Ecosystem control loop.
Maximum control wiring run length is 1000'.

For additional information, contact LED Center of Excellence at 1.877.346.5338 or LEDs@lutron.com

FIG 4.1 Wiring Diagram

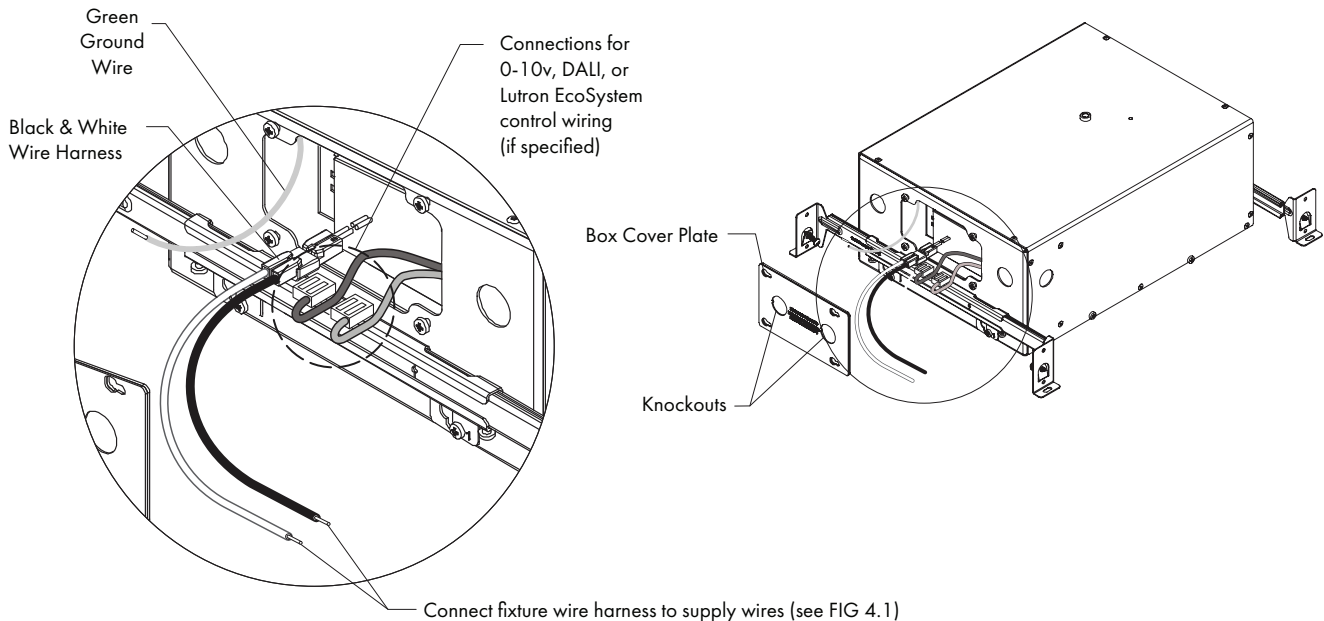

FIG 4.2 Wire Connections

WIRING INSTRUCTIONS - 804D Tunable White

For **EL3 / EL4 / EL5** 2-Channel Dimming Options

CAUTION: TO AVOID RISK OF FIRE OR ELECTRIC SHOCK

Turn off power at circuit breaker or fuse panel & read instructions completely before proceeding.

Failure to follow instructions may void warranty. Save these instructions.

- Installation must be by a qualified electrician only and must conform to National Electric code and local regulations.
- Verify correct dimming system, lamp module, power supply type, and input supply requirements.
- Always allow LED assembly to cool before servicing.
- Do not install where insulation or ambient temperatures will exceed maximum values noted in product specifications. See www.8lighting.com for current product specifications.

804D Tunable White Wiring

EL3 2-Channel DALI CONTROL

1. Loosen screws slightly & slide off Cover Plate. Verify correct dimming system, power supply type and input supply requirements-FIG 1.1.
2. Connect input power & control wires as shown-FIG 1.1 & 1.2.
3. Push all wires & connections completely inside wiring enclosure-FIG 1.2.
4. Re-install Cover Plate using Screws provided-FIG 1.2.

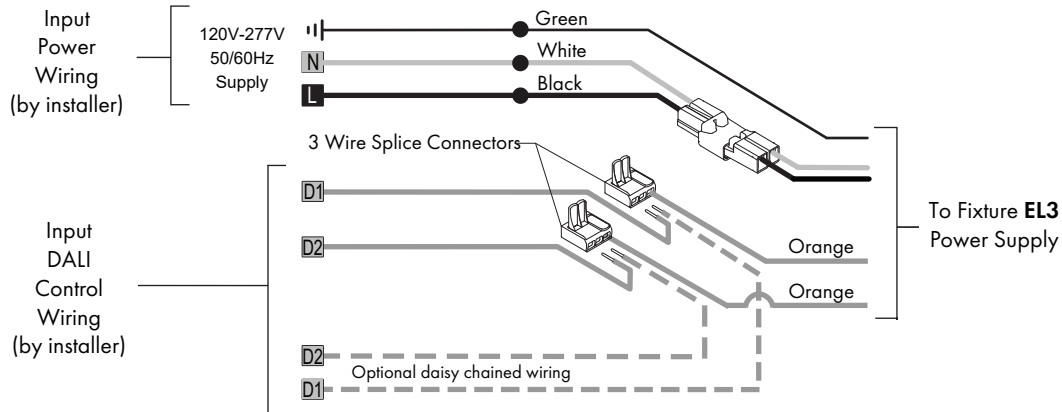

DALI Control Notes:

DALI control wiring is not polarity sensitive and can be run as Class 1 or 2. Each **EL3** driver will be discovered with two incremented short addresses: one for CCT and one for INTENSITY. Up to 32 **EL3** drivers can be daisy-chained per DALI control loop. Maximum control wiring run length is 1000'. For compatible dimmers for use with **EL3** drivers see: www.8lighting.com/resources-downloads.

FIG 1.1 Wiring Diagram

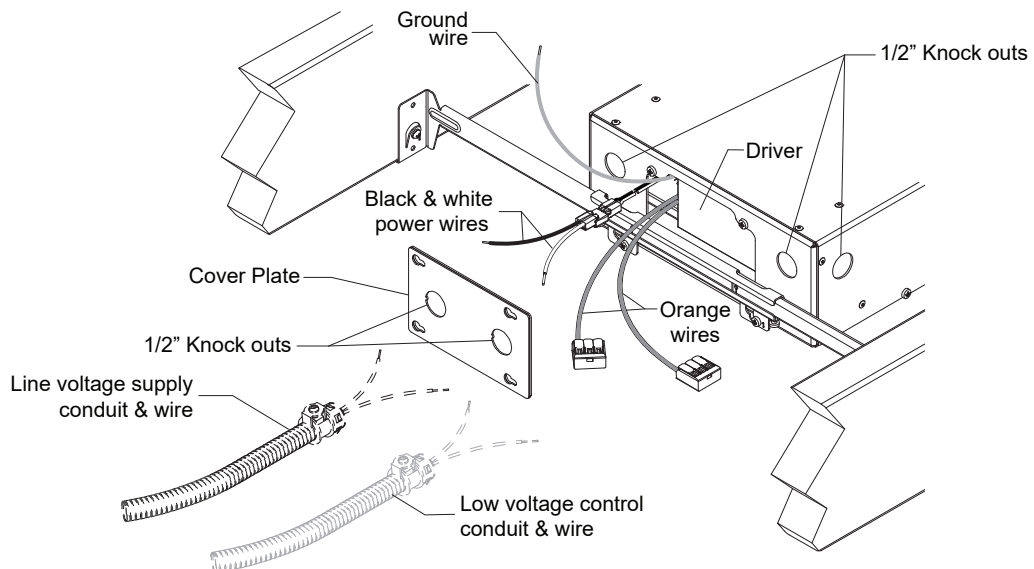
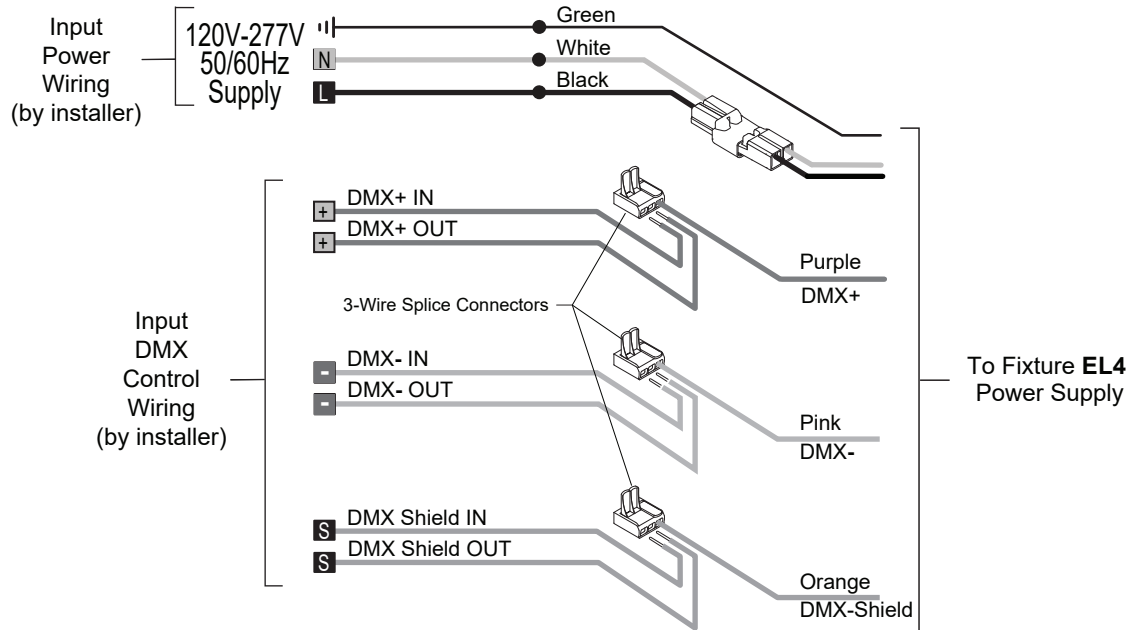

FIG 1.2 Wire Connections

804D Tunable White Wiring

EL4 - 2 CHANNEL DMX CONTROL

1. Loosen screws slightly & slide off Cover Plate. Verify correct dimming system, power supply type and input supply requirements-Fig 2.1.
2. Connect input power & control wires as shown-FIG 2.1 & 2.2.
3. Push all wires & connections completely inside wiring enclosure-FIG 2.2.
4. Re-install Cover Plate using Screws provided-FIG 2.2.



DMX Notes:

DMX control wiring is polarity sensitive and should be run as Class 2. Each **EL4** driver is one "unit load". DMX runs without a repeater/signal booster should be limited to no more than 32 fixtures including controller depending on the site conditions. **EL4** drivers are RDM compatible and addressable by others in the field. Termination of the DMX runs is to be done by others per DMX512A specification. Maximum control wiring run length is 1000'. For compatible dimmers for use with **EL4** drivers see: www.8lighting.com/resources-downloads.

FIG 2.1 Wiring Diagram

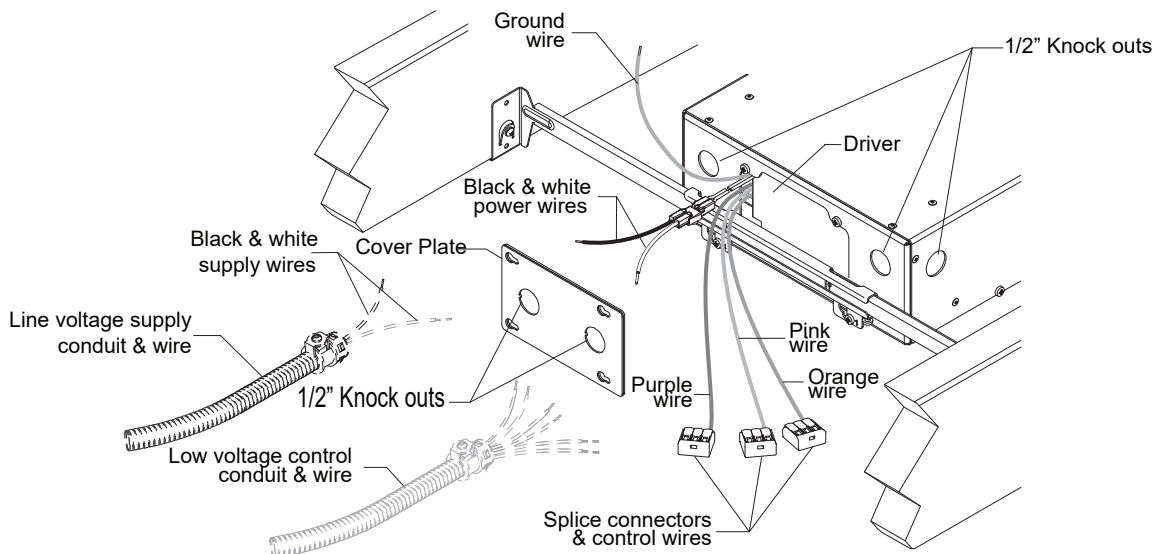
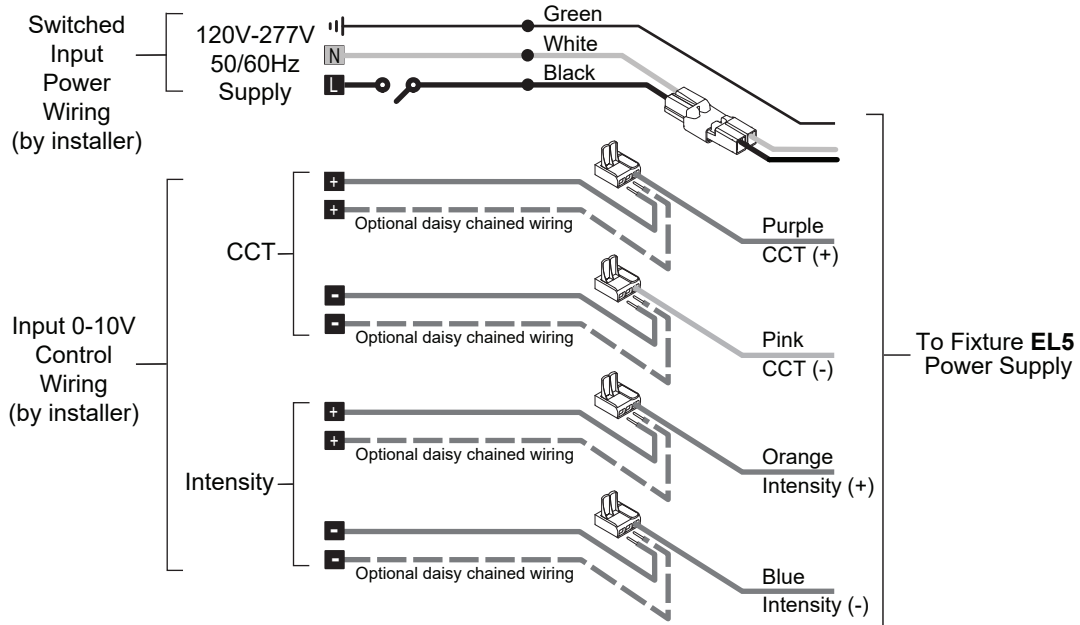

FIG 2.2 Wire Connections

804D Tunable White Wiring

EL5 2-CHANNEL 0-10V CONTROL

1. Loosen screws slightly & slide off Cover Plate. Verify correct dimming system, power supply type and input supply requirements-Fig 3.1.
2. Connect input power & control wires as shown-FIG 3.1 & 3.2.
3. Push all wires & connections completely inside wiring enclosure-FIG 3.2.
4. Re-install Cover Plate using Screws provided-FIG 3.2.



0-10V Control Notes:

0-10V control wiring is polarity sensitive and should be run as Class 2. Each **EL5** driver requires two pairs of Class 2 control wires: one pair for CCT and one pair for INTENSITY. 300' is the maximum control wiring run length to reduce EMI susceptibility and voltage drop. Voltage drop should be no greater than 0.3V. For compatible dimmers for use with **EL5** drivers see: www.8lighting.com/resources-downloads.

FIG 3.1 Wiring Diagram

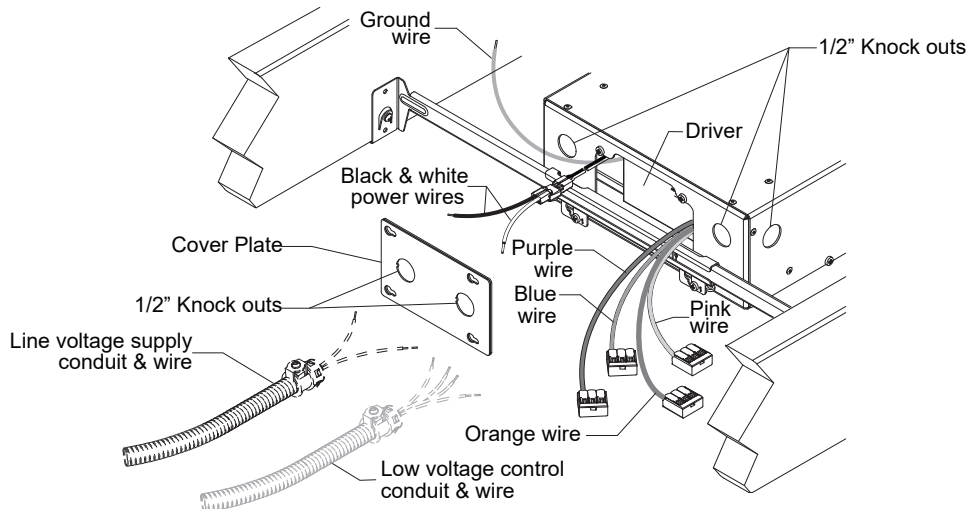

FIG 3.2 Wire Connections