



**200 SERIES**  
**REMODEL**  
TYPE NON-IC RATED  
INSTALLATION INSTRUCTIONS

**WARNING:** Read and understand these instructions completely before installation. Disconnect power at circuit breaker or fuse panel before installation. Always allow LED assembly to cool before servicing. To be installed by qualified electricians only. Products should be installed in accordance with these instructions, local electrical codes, and the National Electric Code (NEC). These products may represent a possible shock or fire hazard if improperly installed.

Do not install where insulation or ambient temperatures will exceed maximum values noted in product specifications. See [www.8lighting.com](http://www.8lighting.com) for current product specifications.



**NOTE:** Number Eight Lighting fixtures are designed to meet the latest NEC requirements and are listed in full compliance with UL standards. Before attempting installation check your local electrical code which sets the wiring standards and installation requirements for your locality.

**Save these instructions.**



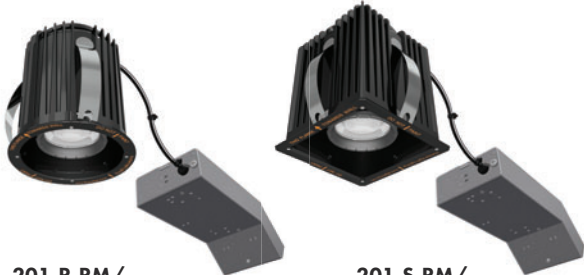

TABLE OF CONTENTS

	PAGE
200-RM SERIES COMPONENTS.....	1
REMODEL INSTALLATION – <b>FLANGED</b> TRIMS .....	2-3
REMODEL INSTALLATION - <b>FLANGELESS TRIMS</b> .....	4-7
AIMING AND ADJUSTMENT and TRIM PLATE FINISHING and INSTALLATION.....	8
WIRING DIAGRAMS.....	9-10



## 200 SERIES REMODEL COMPONENTS

<b>201-RM</b> FIXED POSITION LIGHT ENGINE + POWER SUPPLY	<b>202-RM</b> ADJUSTABLE LIGHT ENGINE + POWER SUPPLY
 <p> <b>201-R-RM/</b>  <b>201-R-BV-RM</b> </p> <p> <b>201-S-RM/</b>  <b>201-S-BV-RM</b> </p>	 <p> <b>202-R-RM/</b>  <b>202-R-BV-RM</b> </p> <p> <b>202-S-RM/</b>  <b>202-S-BV-RM</b> </p>

<b>203-RM</b> WALL WASH LIGHT ENGINE	WALL WASH TRIM PLATES (for 203-R/S-RM Light Engines)
 <p> <b>203-R-RM</b> </p> <p> <b>203-S-RM</b> </p>	 <p> <b>FLR-2-WW</b> </p> <p> <b>FLS-2-WW</b> </p>

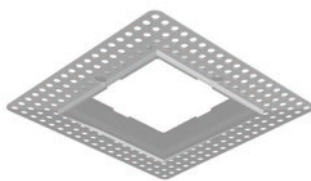
FLAT TRIM PLATES (for 201/202-R/S-RM Light Engines)		BEVEL TRIM PLATES (for 201/202-R/S-BV-RM Light Engines)	
 <p><b>FLR-2</b></p>	 <p><b>FLS-2</b></p>	 <p><b>FLR-2-BV</b></p>	 <p><b>FLS-2-BV</b></p>

FLANGELESS TRIM MOUNTING ACCESSORIES	
 <p> <b>FR-2-RM</b> FLANGELESS TRIM ACCESSORY          (for flush mounting FLR-2/FLR-2-BV/FLR-2-WW trims in REMODEL applications)       </p>	 <p> <b>FS-2-RM</b> FLANGELESS TRIM ACCESSORY          (for flush mounting FLS-2/FLS-2-BV/FLS-2-WW trims in REMODEL applications)       </p>

OPTIC OPTIONS + ACCESSORIES	
<p> <b>TIR-15</b> 15° Narrow spot  <b>TIR-25</b> 25° Narrow flood  <b>TIR-40</b> 40° Flood  <b>TIR-60</b> 60° Wide flood         </p> 	<p> <b>NSP</b> Narrow softening lens  <b>NFL</b> Medium softening lens  <b>FL</b> Wide softening lens  <b>WFL</b> Extra wide softening lens  <b>LS</b> Linear spread Lens         </p> 

REMODEL INSTALLATION - FLANGED TRIMS

**201/202/203-S-RM** and **201/202/203-S-BV-RM** SQUARE LIGHT ENGINES

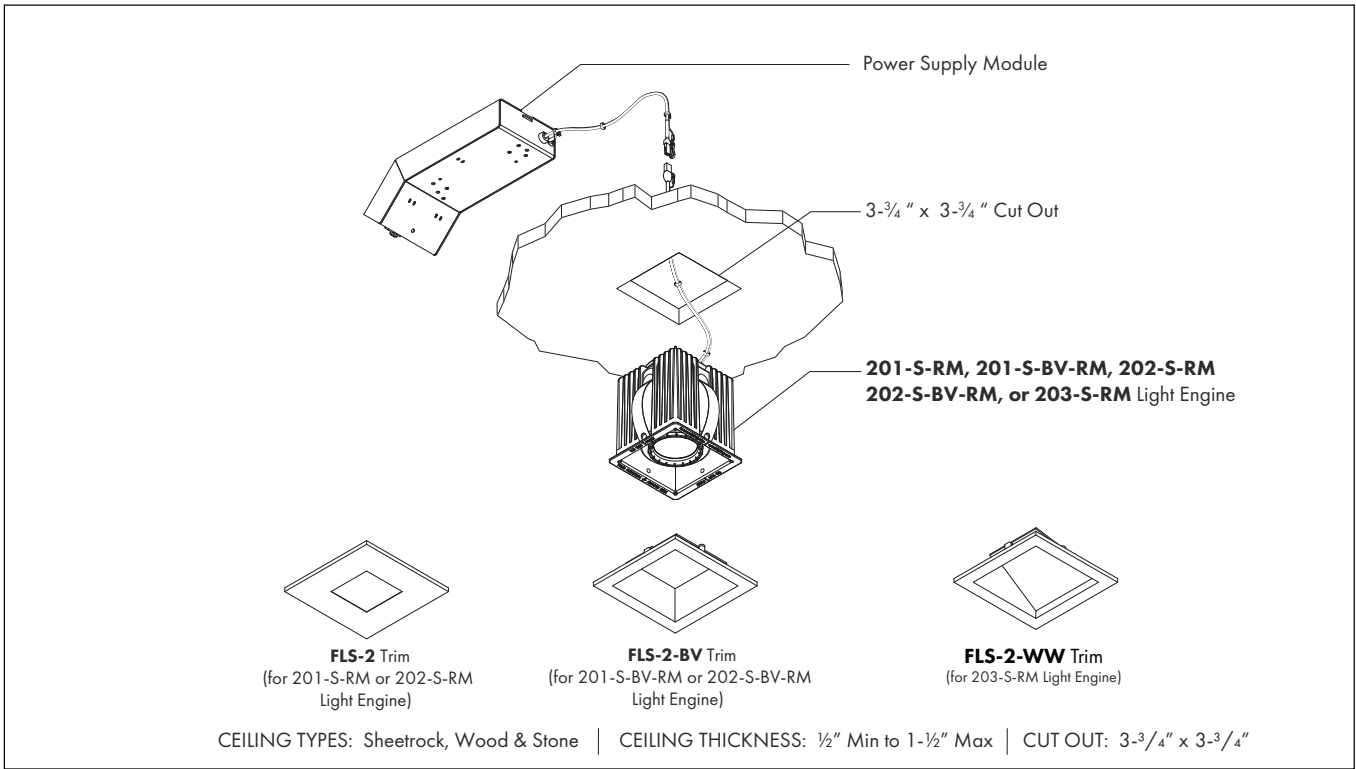

**201/202/203-R-RM** and **201/202/203-R-BV-RM** ROUND LIGHT ENGINES

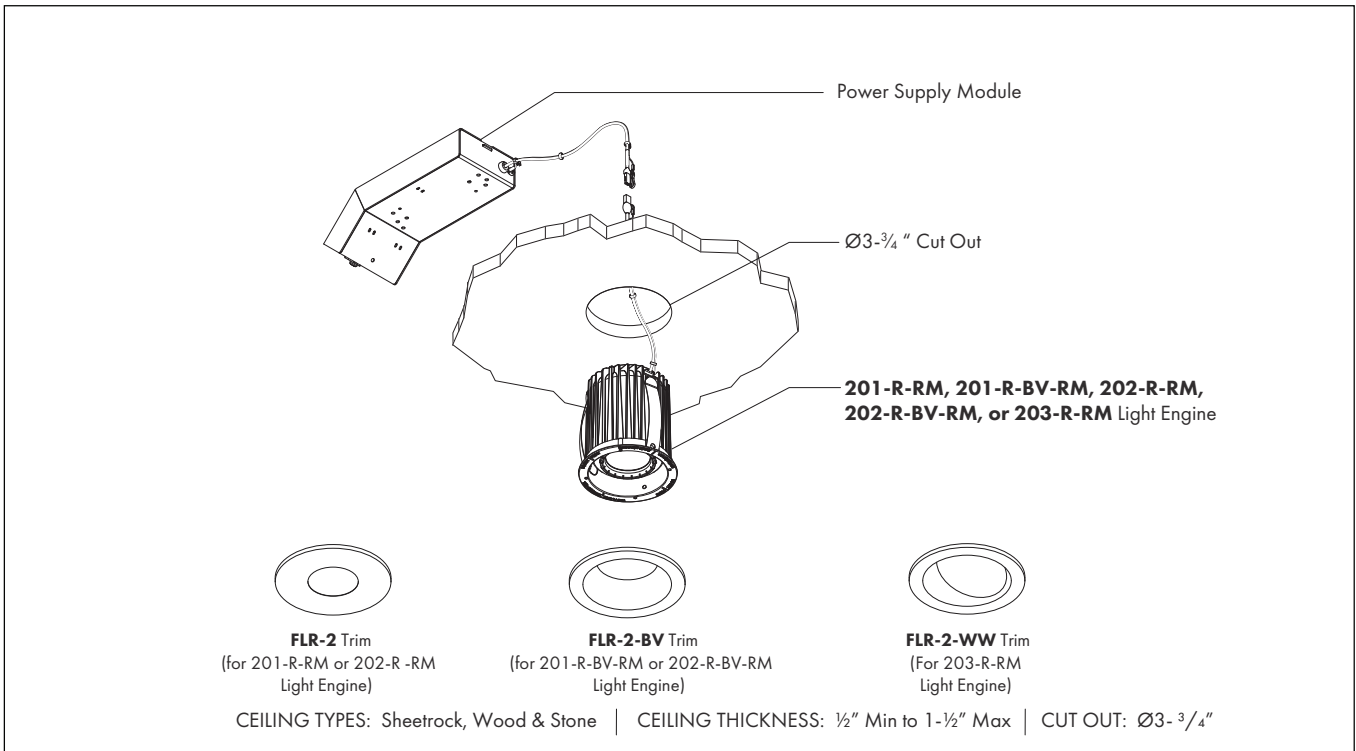

**Caution:** Cut-out must be within ± 1/32" Ceiling material must be rigid and able to support weight of fixture (approximately 5lbs.). Not for use with Acoustic tile or non-rigid ceiling materials. Minimum of 5-1/2" rough ceiling space required for power supply installation.

# REMODEL INSTALLATION - FLANGED TRIMS

## STEP 2 – ROUGH WIRING

- 1a. Disconnect power at circuit breaker.
- 1b. Review wiring diagrams on page 9 & 10, wire accordingly.
- 1c. Install wiring to fixture location leaving a 12" to 18" flexible whip to facilitate installation/servicing.
- Note:** 0-10v, DALI, or EcoSystem power supplies (if specified) require additional dimming control wiring.

## STEP 2 – CEILING CUT-OUT AND INSTALLATION

- 2a. Ensure center of cut-out will be a minimum of 2-1/4" from nearest framing member and there is a minimum of 5-1/2" of rough ceiling space above for installation of power supply.
- 2b. (Skip this step if installing into existing ceiling). Install ceiling material over rough wiring. **Note:** Rough wiring will be accessible after making ceiling cutout. Certain local electrical codes may require rough wiring to be installed in temporary junction box (not supplied) prior to installing ceiling.
- 2c. For sheetrock ceilings - apply all coats of primer & finish paint before making ceiling cut-out.
- 2d. Make cut-outs as shown.

### Round Cut-out

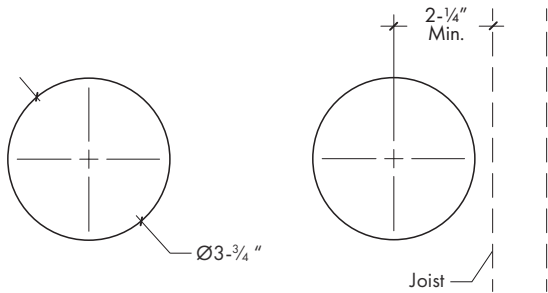

### Square Cut-out

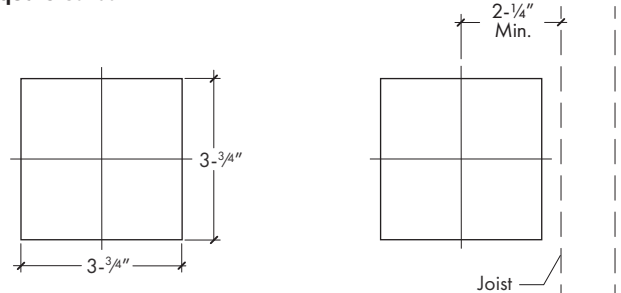

## STEP 3 – FIXTURE WIRING

- 3a. Locate rough wiring and pull through ceiling cut-out ensuring a minimum of 6" of wire extends below the ceiling.

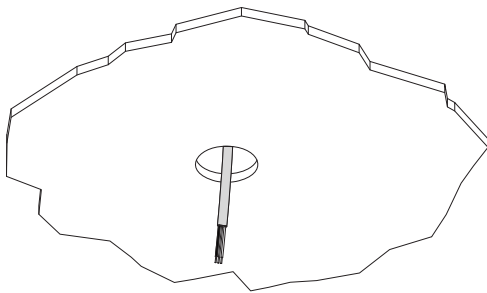

- 3b. Remove box cover on power supply assembly and install appropriate conduit connector (not supplied).

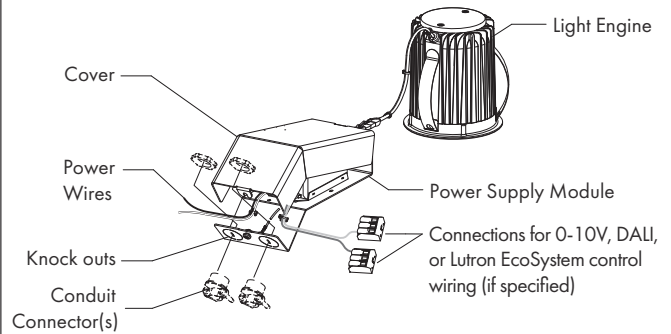

- 3c. Review wiring instructions on page 9 & 10, wire fixture accordingly. Place all wiring connectors back in power supply box and replace cover.

## STEP 4 – LIGHT ENGINE WIRING AND INSTALLATION

- 4a. Attach light engine wire connector & cable ring to power supply side wire connector & cable clip. Install power supply assembly through ceiling cut-out.

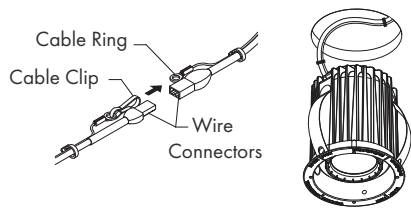

- 4b. Align light engine so arrow shown on flange is perpendicular with adjacent wall.

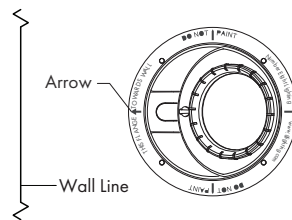

- 4c. Install light engine through cut-out.

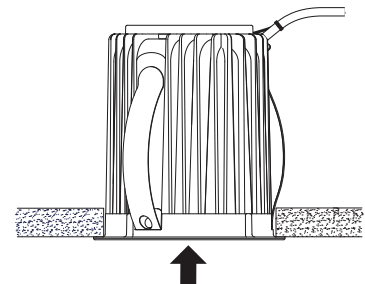

- 4d. Install trim plate (see page 8).

REMODEL INSTALLATION - FLANGELESS TRIMS

**201/202/203-S-RM AND 201/202/203-S-BV-RM SQUARE LIGHT ENGINES**

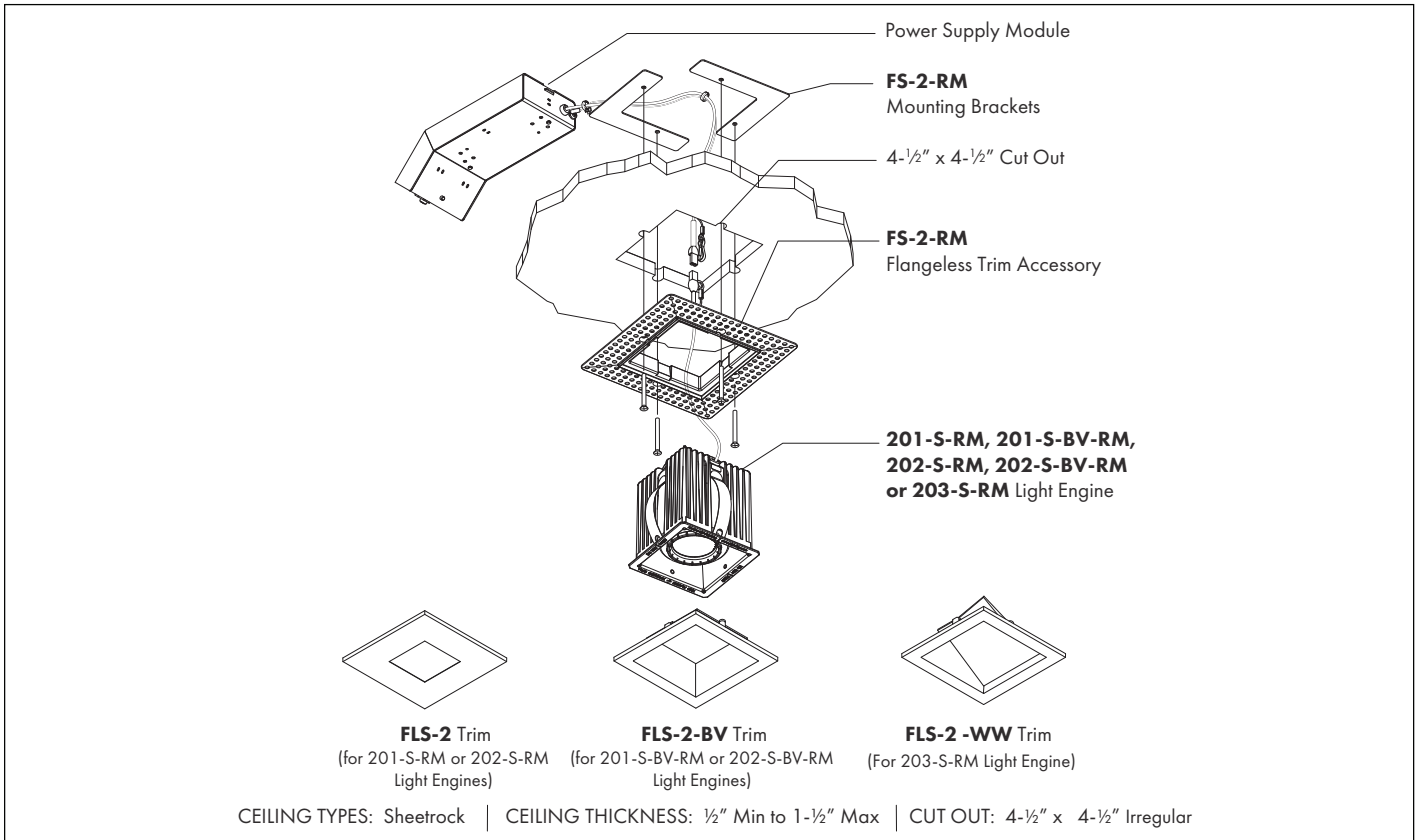

**201/202/203-R-RM AND 201/202/203-R-BV-RM ROUND LIGHT ENGINES**

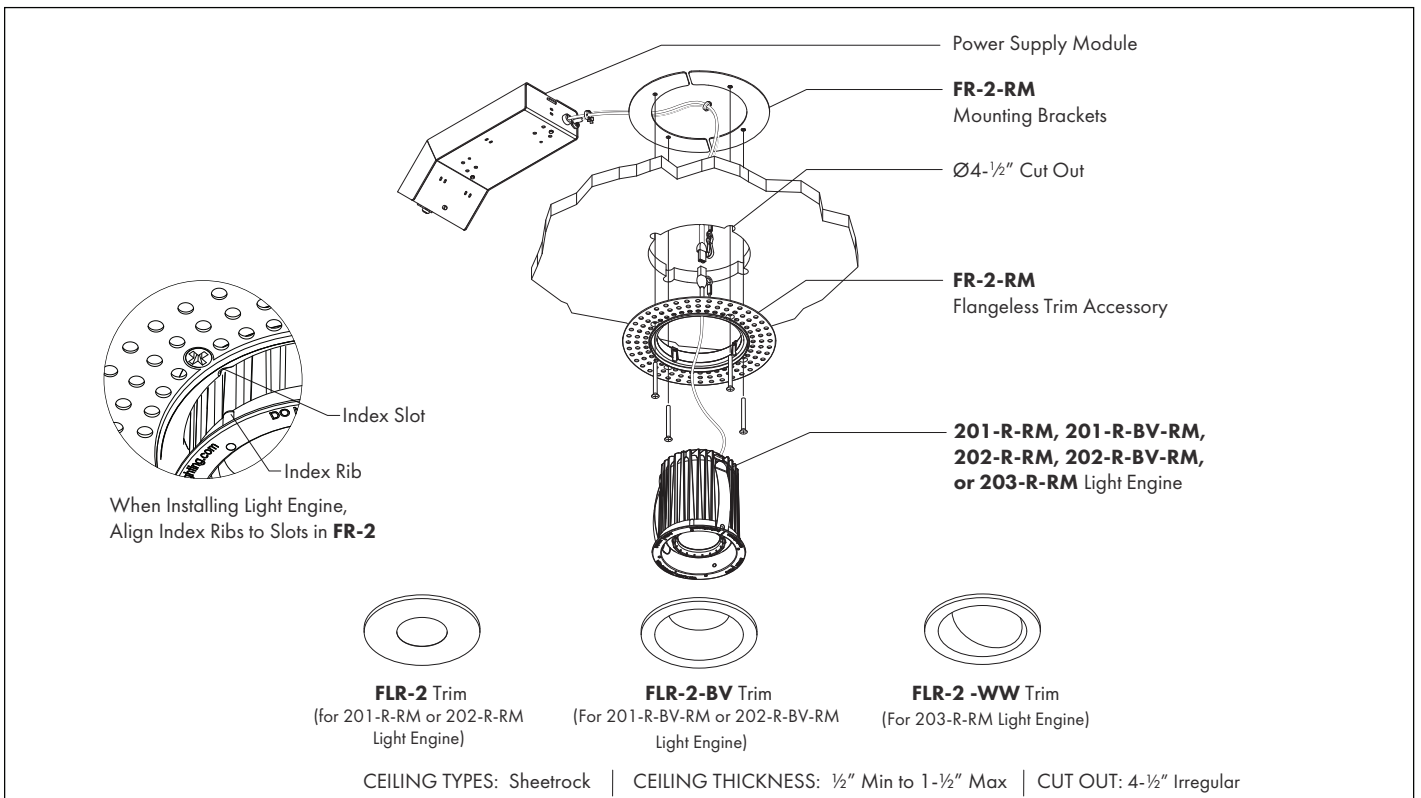

**CAUTION:** For use with sheet rock material only. Cut-out must be within ± 1/16". Minimum of 5-1/2" rough ceiling space required for power supply module installation.

# REMODEL INSTALLATION - FLANGELESS TRIMS

## STEP 1 - ROUGH WIRING

- 1a. Disconnect power at circuit breaker.
- 1b. Review wiring diagrams on page 9 & 10, wire accordingly.
- 1c. Install supply wiring to fixture location leaving a 12-18" flexible whip to facilitate installation/servicing.
- Note:** 0-10, DALI, or EcoSystem power supplies (if specified) require additional dimming control wiring.

## STEP 2 - CEILING CUT-OUT AND INSTALLATION

- 2a. Ensure center of cut-out will be a minimum of 3-1/4" from nearest framing member and there is a minimum of 5-1/2" of rough ceiling space above for installation of power supply.
- 2b. (Skip this step if installing into existing ceiling) Install ceiling material over rough wiring.
- Note:** Rough wiring will be accessible after making ceiling cut-out. Certain local electrical codes may require rough wiring to be installed in temporary junction box (not supplied) prior to installing ceiling.
- 2c. Make cut-outs as shown below.

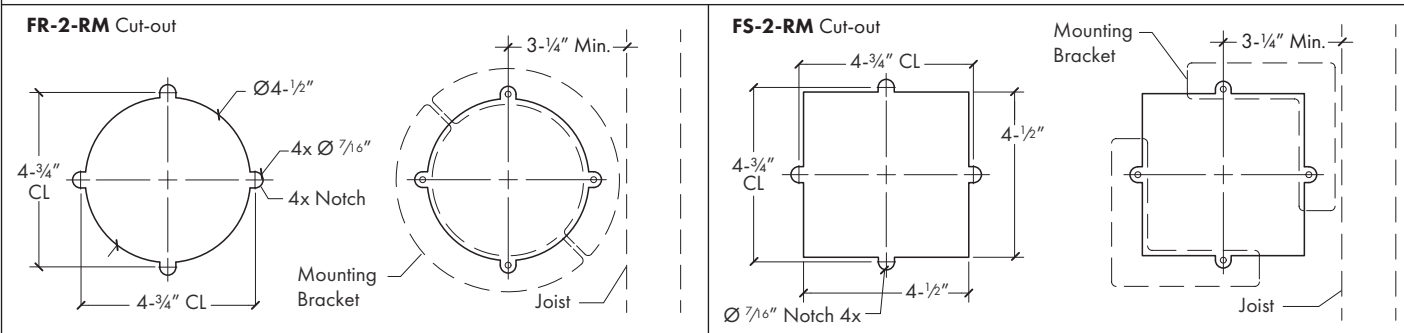

## STEP 3 - FLANGELESS TRIM INSTALLATION

- 3a. Install ceiling brackets through cut-out. Remove mud shield and save. Install trim using four screws. **Note:** do not tighten screws until step 3b.

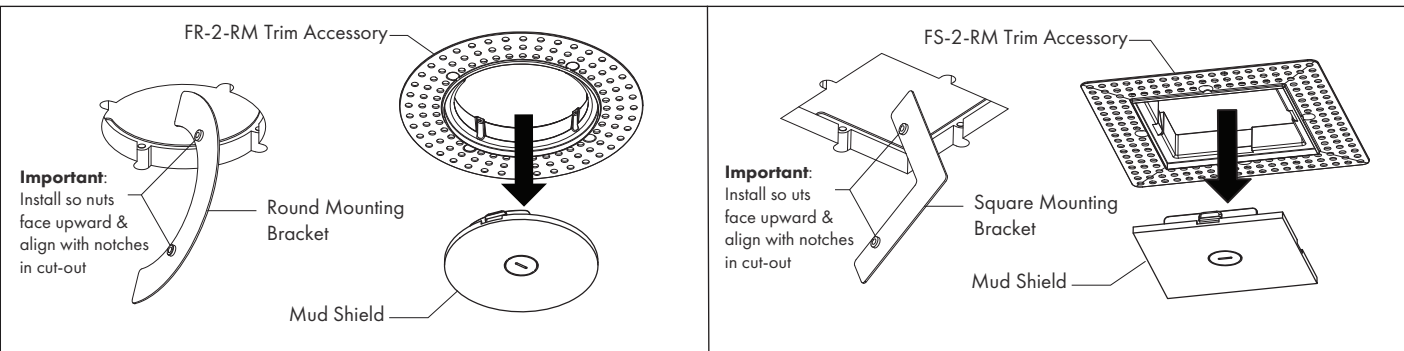

- 3b. Rotate trim to be aligned with adjacent walls or fixtures as shown below. Note: hand tighten trim screws. A power driver is not recommended.

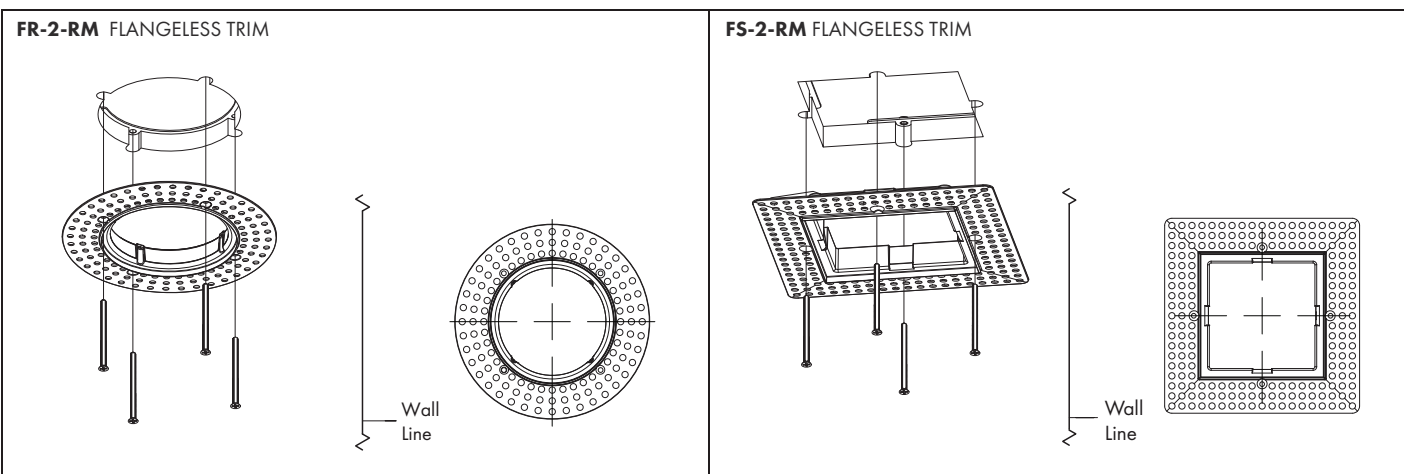



## REMODEL INSTALLATION - FLANGELESS TRIMS

### STEP 3 – FLANGELESS TRIM INSTALLATION (CONTINUED)

**3c.** Reinstall mud shield.

**3d.** Apply 6" wide fiberglass mesh tape over perforated metal trim flange leaving 1/8" cut-out around the outside edge of the raised trim lip and extending over sheetrock.

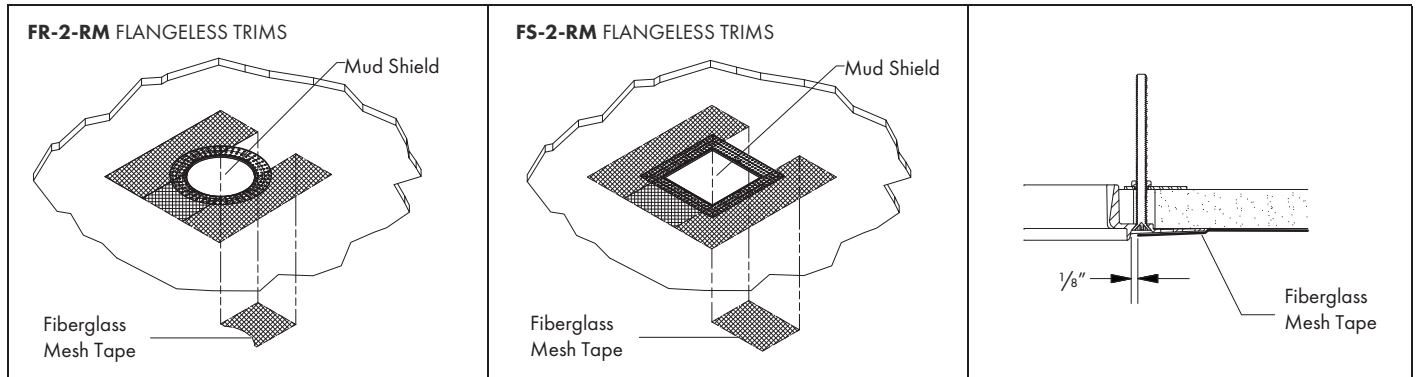

**3e.** Apply ceiling finish around FR-2-RM or FS-2-RM flangeless trim. **NOTE:** Minimum Level 4 or 5 finish is recommended.

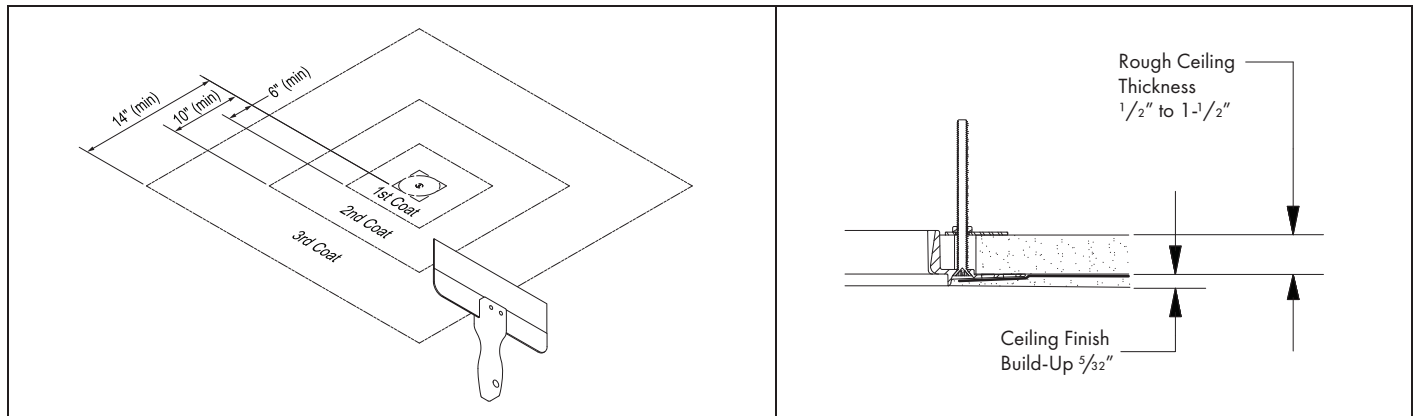

**3f.** First Coat - Apply USG "Durabond" setting-type joint compound for embedding the perforated flange and fiberglass mesh tape following the manufacturer's instructions and warnings for outside corners and trim. The compound should extend a minimum of 6" from the trim edge. Allow first coat to dry completely and remove any high spots by lightly sanding before applying the second coat.

**3g.** Second Coat - Apply USG general purpose ready-mixed joint compound flush to finished edge of trim, floating outward following the manufacturer's instructions and warnings. The compound should extend a minimum of 10" from the trim edge. Allow second coat to dry completely and remove any high spots by lightly sanding before applying the third coat.

**3h.** Third Coat - Apply USG ready-mixed finishing joint compound flush to finished edge of trim, floating outward following the manufacturer's instructions and warnings. The compound should extend a minimum of 14" from the trim edge. Allow third coat to dry completely before sanding.

**3i.** Sand third coat with fine grit sandpaper until mud shield and finished metal edge of trim lip are barely exposed.

**3j.** Remove mud shield.

**3k.** Remove excess material from inside edges of trim.

**3l.** Apply primer (USG Sheetrock or equivalent) and paint following the paint manufacturer's instructions and warnings.

# REMODEL INSTALLATION - FLANGELESS TRIMS

## STEP 4 – FIXTURE WIRING

**4a.** Locate rough wiring and pull through ceiling cut-out ensuring a minimum of 6" of wire extends below the ceiling.

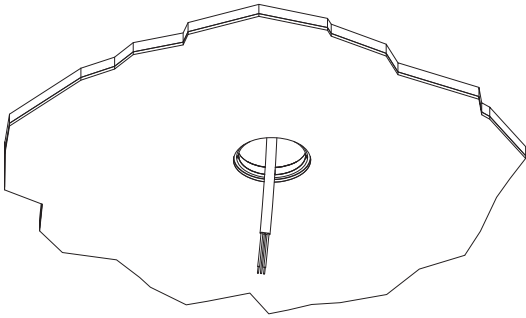

**4b.** Remove box cover on power supply assembly and install appropriate conduit connector (not supplied).

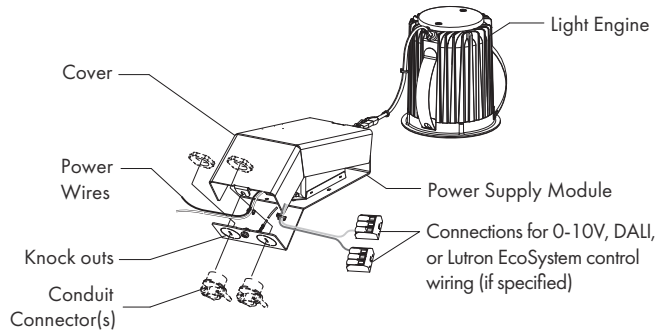

**4c.** Review wiring diagrams on page 9 & 10, wire fixture accordingly. Place all wiring connectors back in power supply box and replace cover.

## STEP 5 – LIGHT ENGINE WIRING AND INSTALLATION

**5a.** Attach light engine wire connector & cable ring to power supply side wire connector & cable clip. Install power supply assembly through ceiling cut-out.

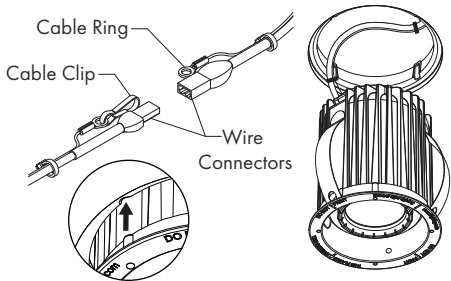

Align Index Ribs & Slots when installing Light Engine.

**5b.** Rotate light engine so the arrow aligns with adjacent walls.

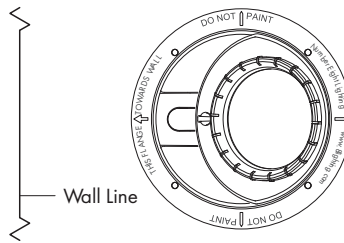

**5c.** Install light engine into flangeless trim.

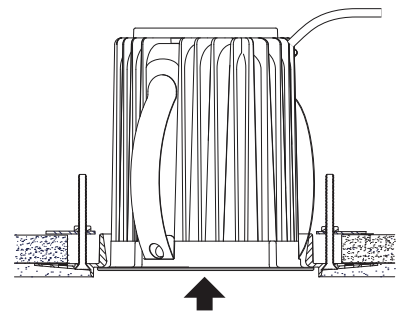

**5d.** Install trim plate (see page 8).

## AIMING & ADJUSTMENT

### STEP 1 – VERTICAL AND HORIZONTAL AIMING AND ADJUSTMENT (Adjustable light engine models 202-R/S or 202-R/S-BV only)

- 1b. Adjust vertical aiming by sliding the lamp holder to desired angle (0-30°)
- 1a. Adjust the horizontal aiming by rotating the lamp holder & housing to desired angle (0-360°)

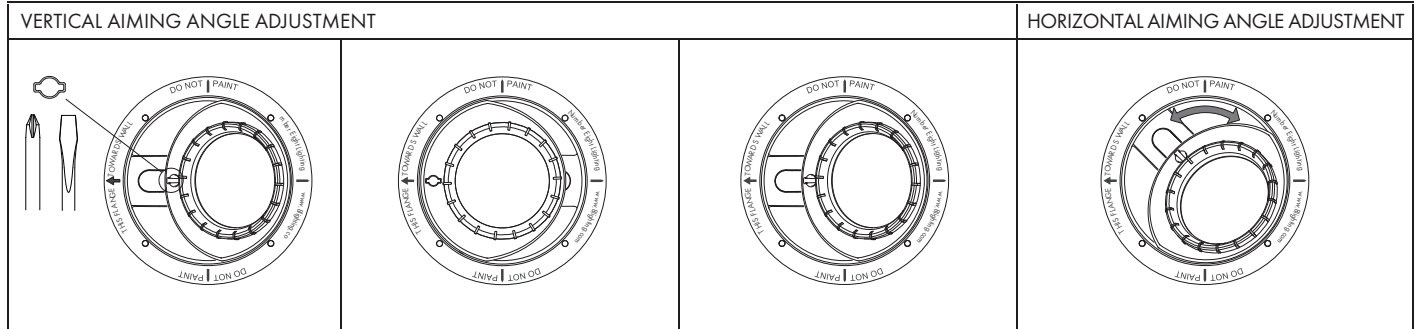

### STEP 2 – LENS AND ACCESSORY REMOVAL AND REPLACEMENT

- 2a. Remove the lens ring from the lamp holder by unscrewing counter-clockwise.
- 2b. Remove optic lens (and accessory lens if used) by gently pressing upward in the center while holding the lens ring.
- 2c. Install desired optic (and accessory lens if used) by aligning the optic lens in lens ring.
- 2d. Reinstall lens ring on to lamp holder by turning clockwise.

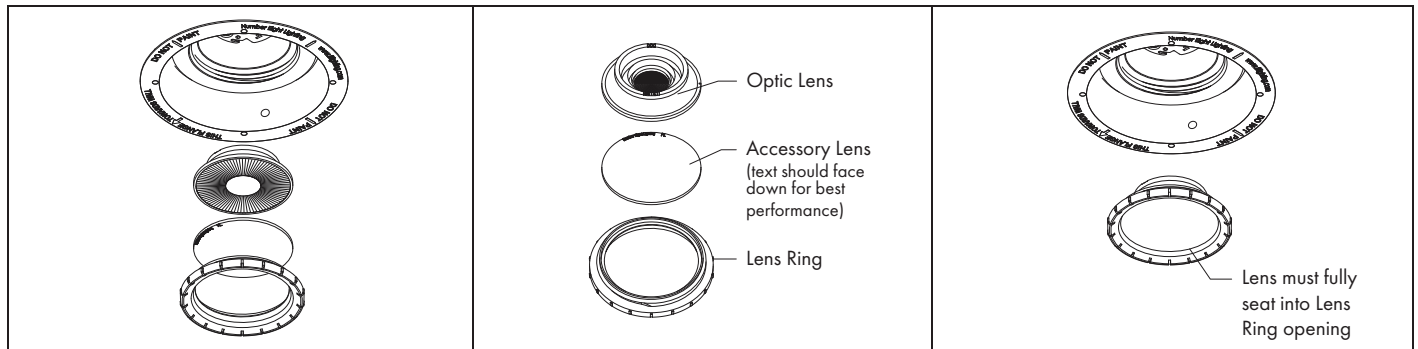

## TRIM PLATE FINISHING & INSTALLATION

### STEP 1. (OPTIONAL) - PAINT TRIM PLATE

- 1a. Remove the trim plate from packaging.
- 1b. Clean and prepare exposed surfaces for painting following the paint manufacturers instructions and warnings.
- 1c. Paint as desired using a "dry roller" or light spray application
- Note:** If applying paint by spray method, mask trim plate lens (if installed).
- Caution:** Paint must be rated for minimum 90 C (150 F). Do not paint trim plate while installed in fixture. Do not paint backside of trim plate or safety cable. Do not paint edges of trim plate if using with FR-2 or FS-2 flangeless trim.
- 1d. Allow trim plate to dry completely before installing.

### STEP 2 – INSTALL TRIM PLATE

- 2a. Loosen set screw in trim plate to accept safety cable.
- 2b. Extend trim safety cable out of housing and insert ferrule at end of the cable under set screw from side and secure with hex key.

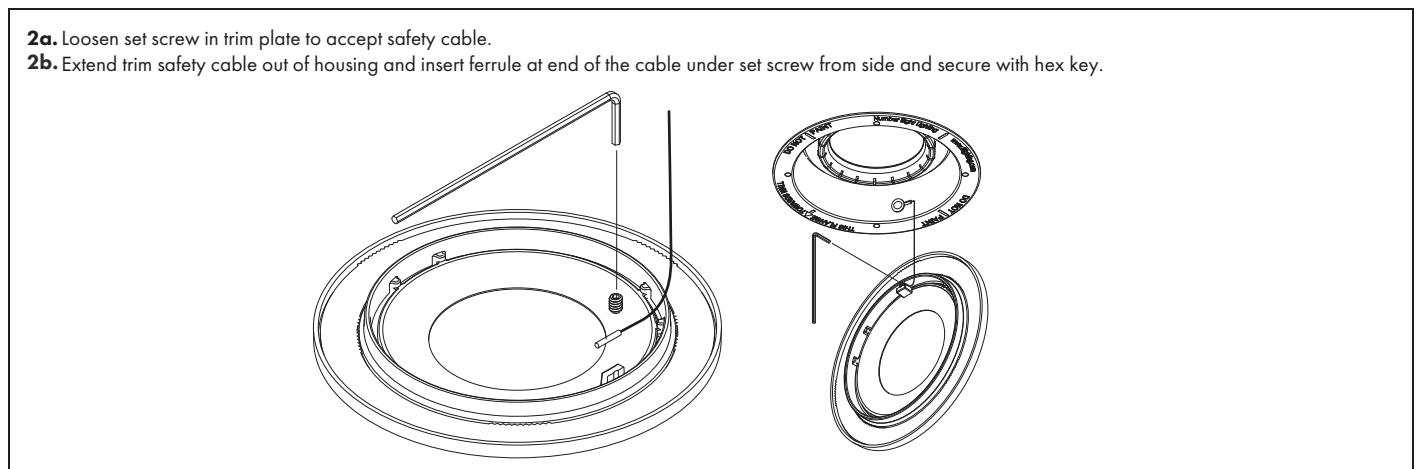

# WIRING DIAGRAMS

## DIM1 / DIM3 / LU1 - PHASE CONTROL

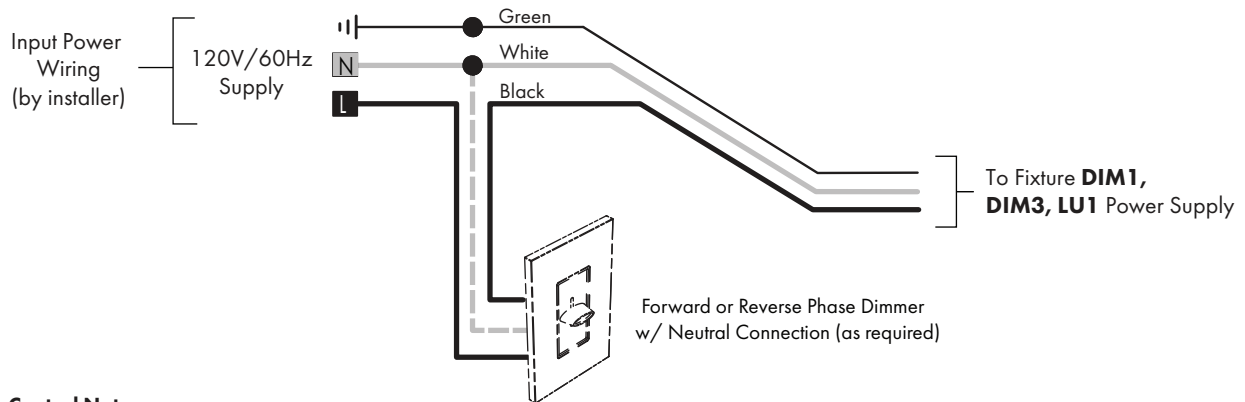

### Phase Control Notes:

**DIM1 / DIM3** drivers are Forward or Reverse Phase dimmable.

For compatible dimmers for use with **DIM1 / DIM3** drivers see: [www.8lighting.com/resources-downloads](http://www.8lighting.com/resources-downloads)

**LU1** drivers are Forward Phase dimmable only.

For compatible dimmers for use with **LU1** drivers, contact Lutron LED Center of Excellence at 1.877.346.5338 or [LEDs@lutron.com](mailto:LEDs@lutron.com)

## DIM2 / DIM4 / EL1 - 0-10V CONTROL

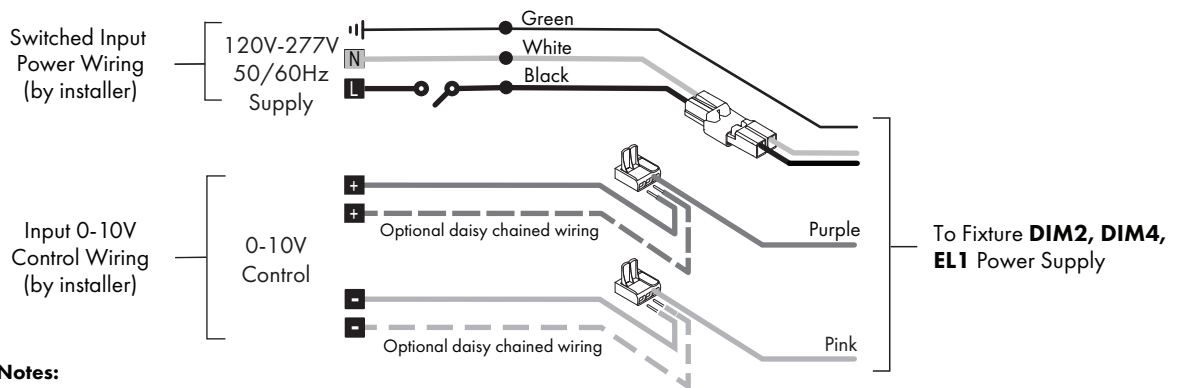

### 0-10V Control Notes:

0-10V control wiring is polarity sensitive and should be run as Class 2.

300' is the maximum control wiring run length to reduce EMI susceptibility and voltage drop. Voltage drop should be no greater than 0.3V.

For compatible dimmers for use with **DIM2 / DIM4 / EL1** drivers see: [www.8lighting.com/resources-downloads](http://www.8lighting.com/resources-downloads).

## EL2 - DALI CONTROL

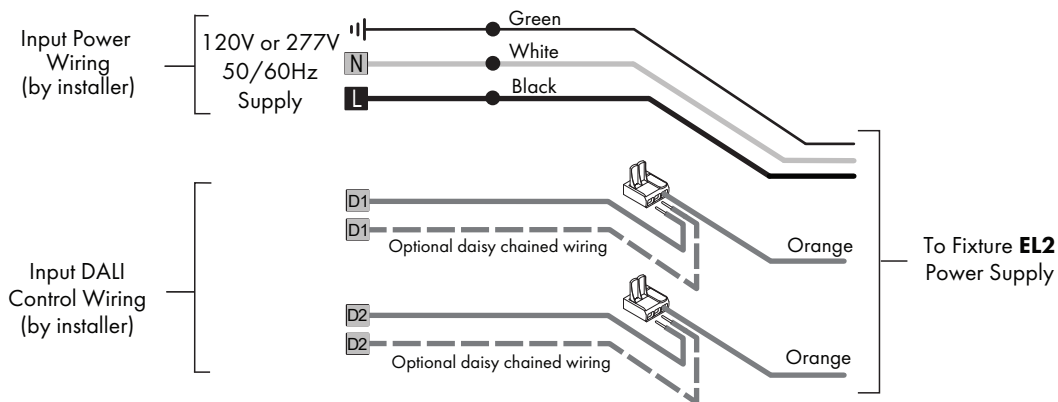

### DALI Control Notes:

DALI control wiring is not polarity sensitive and can be run as Class 1 or 2. Up to 64 **EL2** power supplies can be daisy chained per DALI control loop. Maximum control wiring run length is 1000'.

For compatible dimmers for use with **EL2** drivers see: [www.8lighting.com/resources-downloads](http://www.8lighting.com/resources-downloads)

# WIRING DIAGRAMS

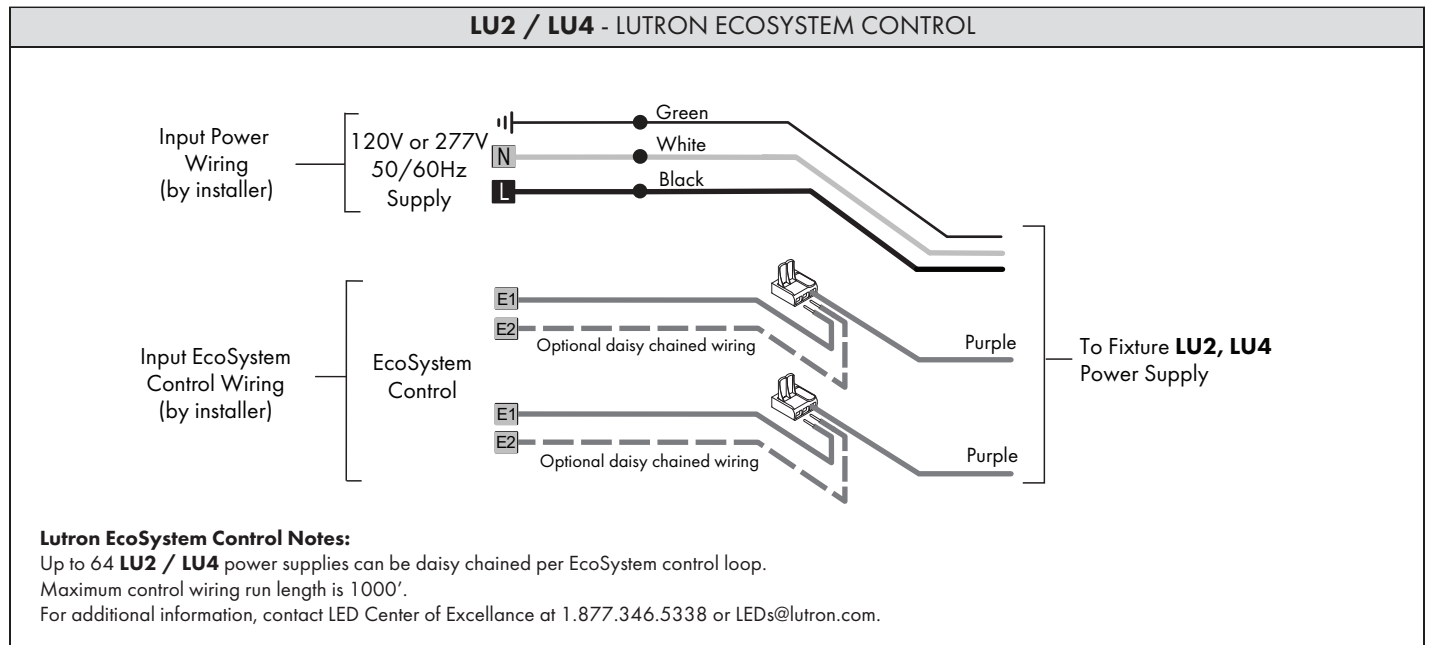



[www.8lighting.com](http://www.8lighting.com)

Number Eight Lighting Company, 526 Portal Street, Cotati, CA 94931  
Phone: (707) 794-0888 Fax: (707) 795-4379 Email: [customerservice@8lighting.com](mailto:customerservice@8lighting.com)