

INSTALLATION INSTRUCTIONS - MPT2-RT-R/S-Monopoint

For Remote Dimming Options with 2-1/2" Backplate

CAUTION: TO AVOID RISK OF FIRE OR ELECTRIC SHOCK

Turn off power at circuit breaker or fuse panel & read instructions completely before proceeding. Failure to follow instructions may void warranty. Save these instructions.

- Installation must conform to National Electric code and local regulations.
- Installation must be by a qualified electrician only.
- Verify correct dimming system, LED type, power supply type and input supply requirements.
- Always allow LED assembly to cool before servicing.
- Do not install where insulation or ambient temperature will exceed maximum values noted in product specifications.
- See www.8lighting.com for current product specifications.



MPT2-RT-R



MPT2-RT-S

MPT2-RT-R/S Install and Adjust

Step 1 Verify suitable mounting location and blocking requirements. Fixture does not mount to standard junction box - FIG 1.1.

Step 2 Wire remote power supply according to wiring instructions shown on proceeding pages.

Step 3 Drill 3/4" hole at fixture location through blocking or suitable surface. Route Class 2 wiring from remote power supply to fixture location and pull through hole - FIG 1.4.

Step 4 Install Mounting Bracket after making wire connections. Position Fixture Backplate as desired & tighten set screw in Backplate - FIG 1.3.

Step 5 (Adjustment) Remove Housing from Heat Sink as shown & remove Accessory Ring to remove or install accessories. Loosen set screws slightly (DO NOT remove) with Hex Keys provided to adjust head tilt or rotation as shown. Lock position by tightening set screw - FIG 1.2 & 1.3.



Does not require a standard size junction box.

FIG 1.1

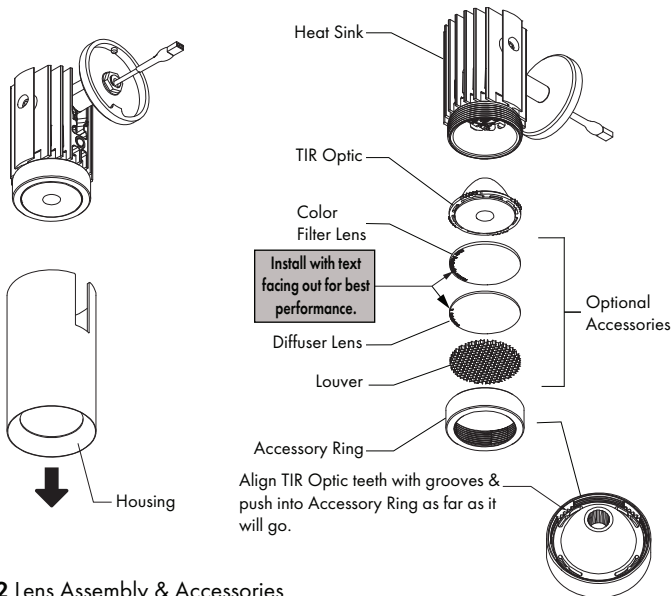

FIG 1.2 Lens Assembly & Accessories

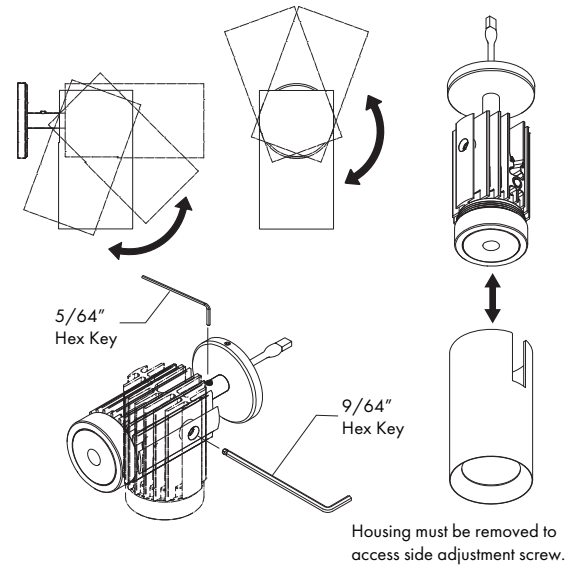

FIG 1.3 Fixture Adjustment

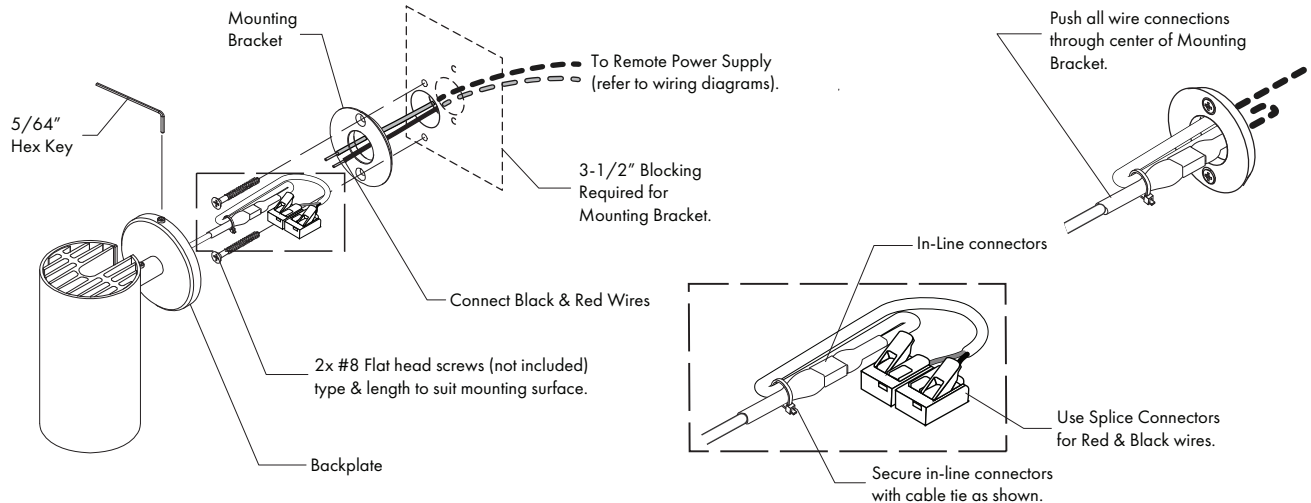

FIG 1.4 Complete Wiring & Install Fixture

WIRING INSTRUCTIONS - MPT2-RT

For DIM1/PR1-M2/M4-RT-1000/1000-WD/1400 Remote Dimming Options

Wiring Connections

1. Verify correct power supply model (see label on cover plate), LED type (see label on fixture), wire length and gauge (see chart below) and input requirements (see label on driver) - FIG 2.2.
2. Install & wire remote power supply assembly - FIG 2.1 & 2.2.
3. Connect fixture supply wires to Class 2 wiring - FIG 2.1 & 2.2.
4. Push fixture supply connections completely behind Mounting Bracket - FIG 1.3 & 2.2.

DIM1/PR1-M2/M4-RT-1000/1000-WD/1400 - REMOTE PHASE CONTROL

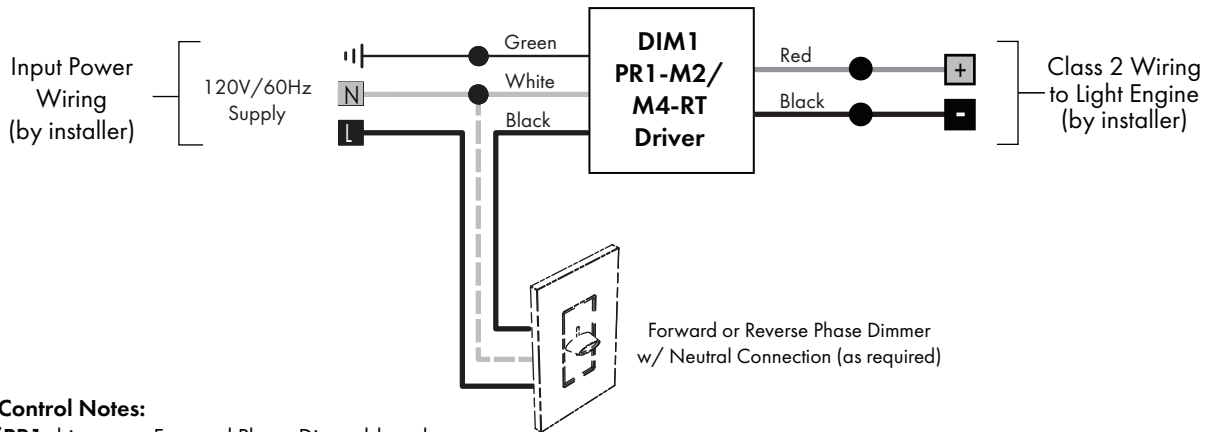

Phase Control Notes:

DIM1/PR1 drivers are Forward Phase Dimmable only.
for compatible dimmers for use with **DIM1/PR1** drivers see: www.8lighting.com/resources-downloads.

FIG 2.1 Wiring Diagram

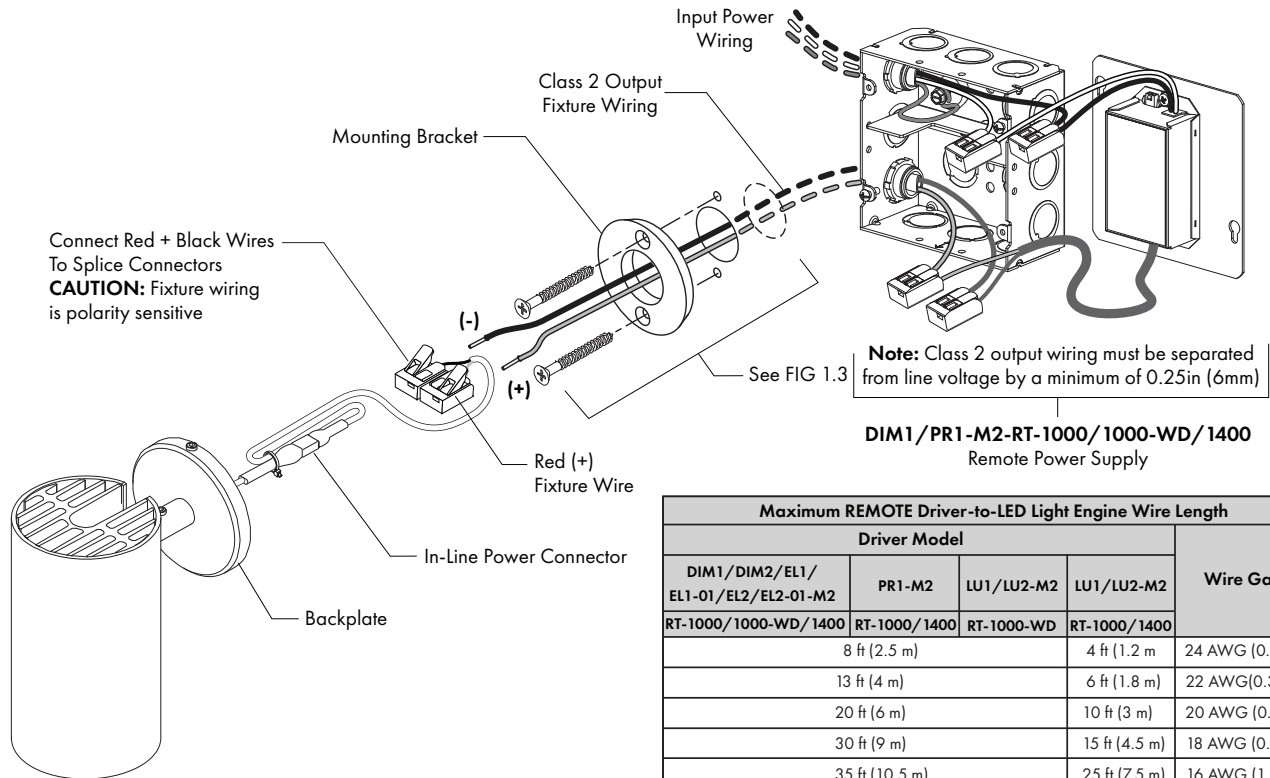

FIG 2.2 Wire & Install Remote Power Supply

Maximum REMOTE Driver-to-LED Light Engine Wire Length				
Driver Model				Wire Gauge
DIM1/DIM2/EL1/ EL1-01/EL2/EL2-01-M2	PR1-M2	LU1/LU2-M2	LU1/LU2-M2	
RT-1000/1000-WD/1400	RT-1000/1400	RT-1000-WD	RT-1000/1400	
	8 ft (2.5 m)		4 ft (1.2 m)	24 AWG (0.2mm ²)
	13 ft (4 m)		6 ft (1.8 m)	22 AWG(0.34mm ²)
	20 ft (6 m)		10 ft (3 m)	20 AWG (0.5 mm ²)
	30 ft (9 m)		15 ft (4.5 m)	18 AWG (0.75 m ²)
	35 ft (10.5 m)		25 ft (7.5 m)	16 AWG (1.5 mm ²)
	50 ft (15 m)		40 ft (12m)	14 AWG (2.5 mm ²)
	100 ft (30 m)		60 ft (18 m)	12 AWG (4.0 mm ²)

Wire Type: Stranded Class 2 wire (supplied by others)

WIRING INSTRUCTIONS - MPT2-RT (continued)

For DIM2-M2/M4-RT-1000/1000-WD/1400 Remote Dimming Options

Wiring Connections

1. Verify correct power supply model (see label on cover plate), LED type (see label on fixture), wire length and gauge (see chart below) and input requirements (see label on driver) - FIG 3.2.
2. Install & wire remote power supply assembly - FIG 3.1 & 3.2.
3. Connect fixture supply wires to Class 2 wiring - FIG 3.1 & 3.2.
4. Push fixture supply connections completely behind Mounting Bracket - FIG 1.3 & 3.2.

DIM2/M4-RT-1000/1000-WD/1400 - REMOTE 0-10V CONTROL

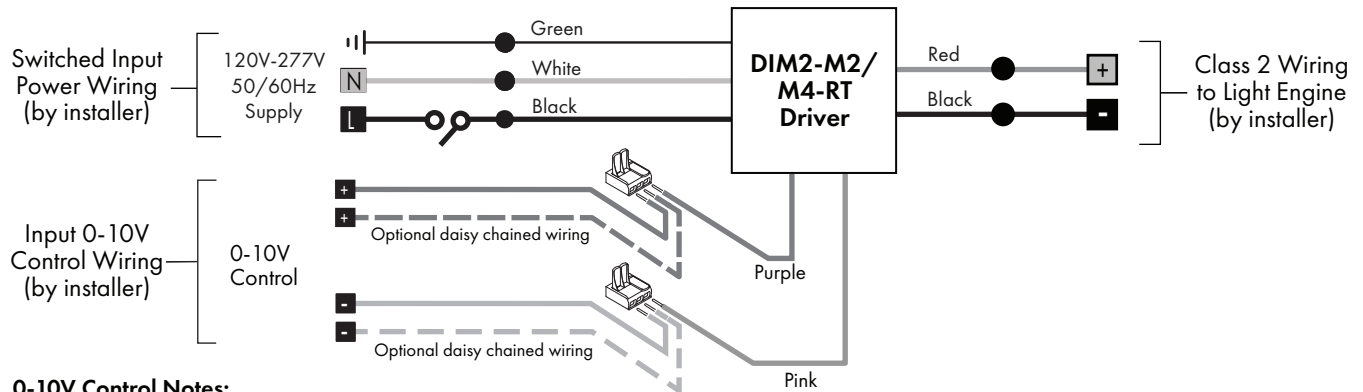

0-10V Control Notes:

0-10V control wiring is polarity sensitive and should be run as Class 2. 300' is the maximum control wiring run length to reduce EMI susceptibility and voltage drop. Voltage drop should be no greater than 0.3V. For compatible dimmers for use with **DIM2** drivers see: www.8lighting.com/resources-downloads.

FIG 3.1 Wiring Diagram

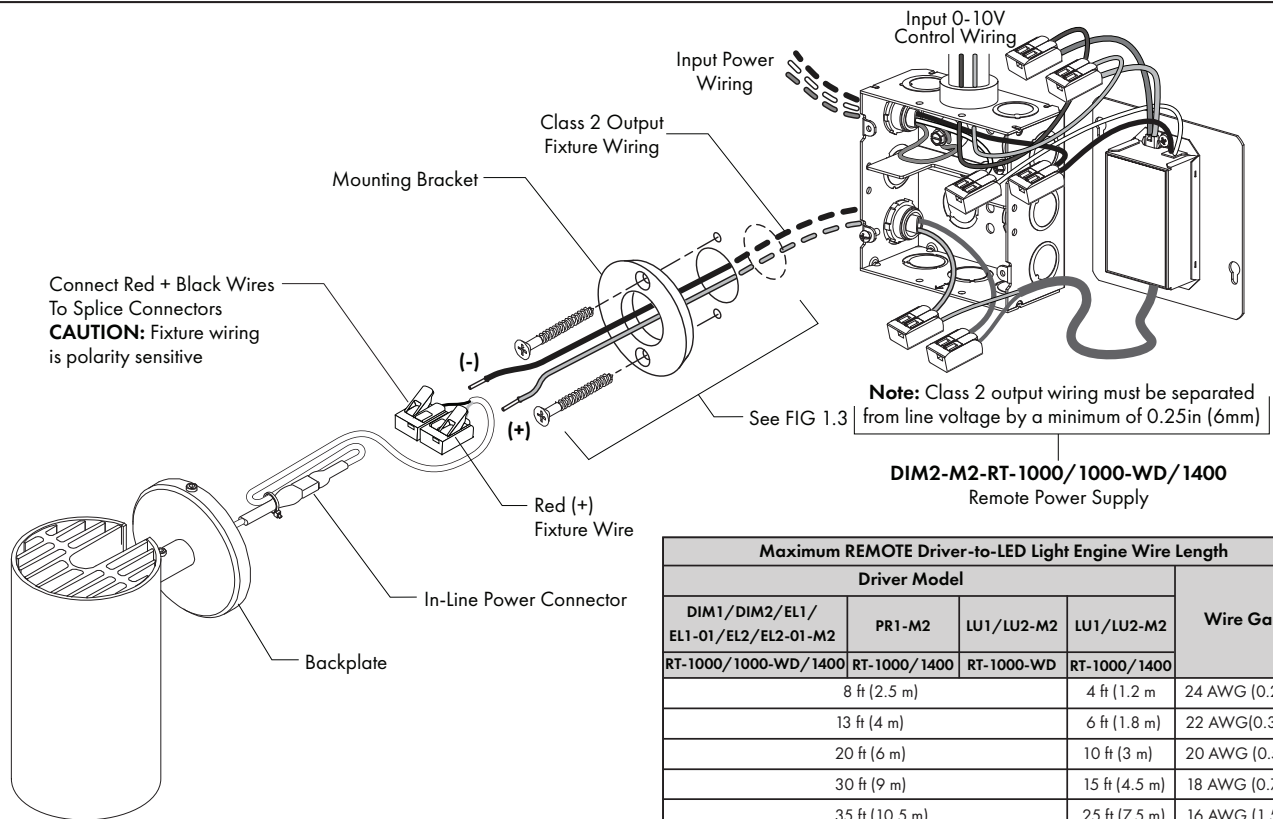

FIG 3.2 Wire & Install Remote Power Supply

Maximum REMOTE Driver-to-LED Light Engine Wire Length				
Driver Model				Wire Gauge
DIM1/DIM2/EL1/EL1-01/EL2/EL2-01-M2	PR1-M2	LU1/LU2-M2	LU1/LU2-M2	
RT-1000/1000-WD/1400	RT-1000/1400	RT-1000-WD	RT-1000/1400	
8 ft (2.5 m)			4 ft (1.2 m)	24 AWG (0.2mm ²)
13 ft (4 m)			6 ft (1.8 m)	22 AWG (0.34mm ²)
20 ft (6 m)			10 ft (3 m)	20 AWG (0.5 mm ²)
30 ft (9 m)			15 ft (4.5 m)	18 AWG (0.75 mm ²)
35 ft (10.5 m)			25 ft (7.5 m)	16 AWG (1.5 mm ²)
50 ft (15 m)			40 ft (12m)	14 AWG (2.5 mm ²)
100 ft (30 m)			60 ft (18 m)	12 AWG (4.0 mm ²)

Wire Type: Stranded Class 2 wire (supplied by others)

WIRING INSTRUCTIONS - MPT2-RT (continued)

For EL1/EL1-01-M2 /M4-RT-1000/1000-WD/1400 Remote Dimming Option

Wiring Connections

1. Verify correct power supply model (see label on cover plate), LED type (see label on fixture), wire length and gauge (see chart below) and input requirements (see label on driver) - FIG 4.2.
2. Install & wire remote power supply assembly - FIG 4.1 & 4.2.
3. Connect fixture supply wires to Class 2 wiring - FIG 4.1 & 4.2.
4. Push fixture supply connections completely behind Mounting Bracket - FIG 1.3 & 4.2.

EL1/EL1-01-M2/M4-RT-1000/1000-WD/1400 - REMOTE 0-10V CONTROL

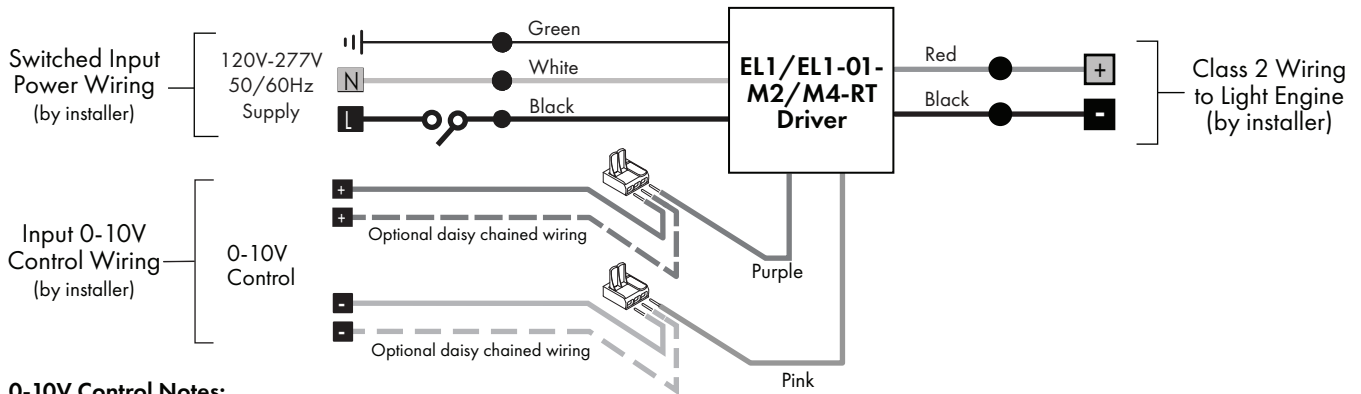

0-10V Control Notes:

0-10V control wiring is polarity sensitive and should be run as Class 2. 300' is the maximum control wiring run length to reduce EMI susceptibility and voltage drop. Voltage drop should be no greater than 0.3V. For compatible dimmers for use with **EL1** drivers see: www.8lighting.com/resources-downloads.

FIG 4.1 Wiring Diagram

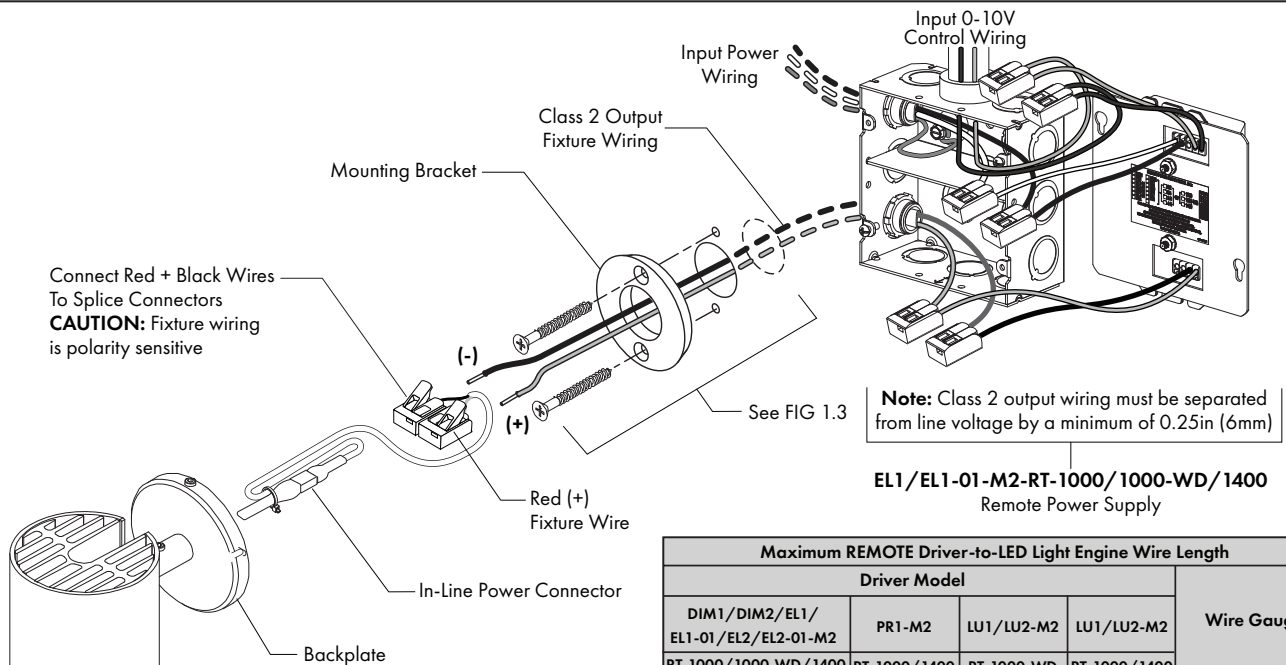

FIG 4.2 Wire & Install Remote Power Supply

Maximum REMOTE Driver-to-LED Light Engine Wire Length				
Driver Model				Wire Gauge
DIM1/DIM2/EL1/EL1-01/EL2/EL2-01-M2	PR1-M2	LU1/LU2-M2	LU1/LU2-M2	
RT-1000/1000-WD/1400	RT-1000/1400	RT-1000-WD	RT-1000/1400	
	8 ft (2.5 m)		4 ft (1.2 m)	24 AWG (0.2mm ²)
	13 ft (4 m)		6 ft (1.8 m)	22 AWG (0.34mm ²)
	20 ft (6 m)		10 ft (3 m)	20 AWG (0.5 mm ²)
	30 ft (9 m)		15 ft (4.5 m)	18 AWG (0.75 mm ²)
	35 ft (10.5 m)		25 ft (7.5 m)	16 AWG (1.5 mm ²)
	50 ft (15 m)		40 ft (12m)	14 AWG (2.5 mm ²)
	100 ft (30 m)		60 ft (18 m)	12 AWG (4.0 mm ²)

Wire Type: Stranded Class 2 wire (supplied by others)

WIRING INSTRUCTIONS - MPT2-RT (continued)

For EL2/EL2-01-M2 /M4-RT-1000/1000-WD/1400 Remote Dimming Option

Wiring Connections

1. Verify correct power supply model (see label on cover plate), LED type (see label on fixture), wire length and gauge (see chart below) and input requirements (see label on driver) - FIG 5.2.
2. Install & wire remote power supply assembly - FIG 5.1 & 5.2.
3. Connect fixture supply wires to Class 2 wiring - FIG 5.1 & 5.2.
4. Push fixture supply connections completely behind Mounting Bracket - FIG 1.3 & 5.2.

EL2/EL2-01-M2/M4-RT-1000/1000-WD/1400 - REMOTE DALI CONTROL

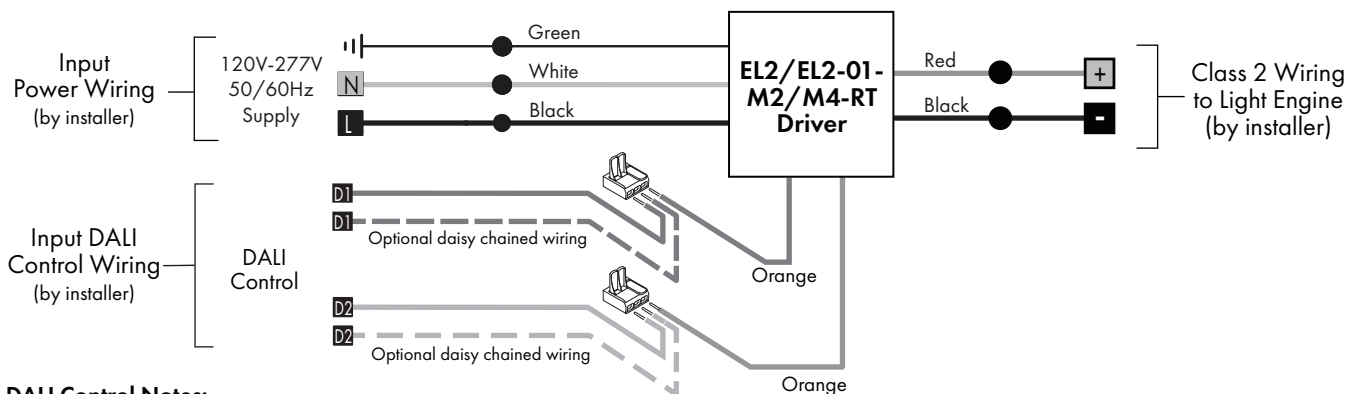

DALI Control Notes:

DALI control wiring IS NOT polarity sensitive and can be run as Class 1 or 2.

Up to 64 **EL2** power supplies can be daisy chained per DALI control loop. Maximum control wiring run length is 1000'.

For compatible dimmers for use with **EL2** drivers see: www.8lighting.com/resources-downloads.

FIG 5.1 Wiring Diagram

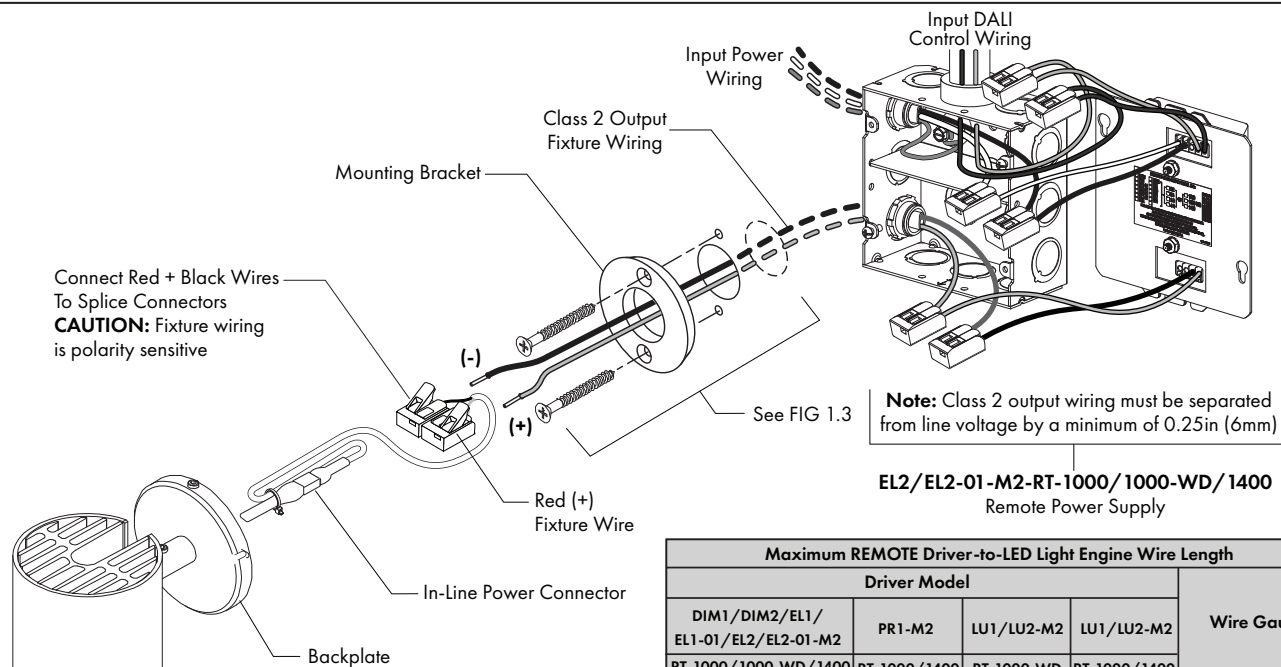

FIG 5.2 Wire & Install Remote Power Supply

Maximum REMOTE Driver-to-LED Light Engine Wire Length				
Driver Model				Wire Gauge
DIM1/DIM2/EL1/ EL1-01/EL2/EL2-01-M2	PR1-M2	LU1/LU2-M2	LU1/LU2-M2	
RT-1000/1000-WD/1400	RT-1000/1400	RT-1000-WD	RT-1000/1400	
	8 ft (2.5 m)		4 ft (1.2 m)	24 AWG (0.2mm ²)
	13 ft (4 m)		6 ft (1.8 m)	22 AWG(0.34mm ²)
	20 ft (6 m)		10 ft (3 m)	20 AWG (0.5 mm ²)
	30 ft (9 m)		15 ft (4.5 m)	18 AWG (0.75 mm ²)
	35 ft (10.5 m)		25 ft (7.5 m)	16 AWG (1.5 mm ²)
	50 ft (15 m)		40 ft (12m)	14 AWG (2.5 mm ²)
	100 ft (30 m)		60 ft (18 m)	12 AWG (4.0 mm ²)

Wire Type: Stranded Class 2 wire (supplied by others)

WIRING INSTRUCTIONS - MPT2-RT (continued)

For LU1-M2/M4-RT-1000/1000-WD/1400 Remote Dimming Option

Wiring Connections

1. Verify correct power supply model (see label on cover plate), LED type (see label on fixture), wire length and gauge (see chart below) and input requirements (see label on driver) - FIG 6.2.
2. Install & wire remote power supply assembly - FIG 6.1 & 6.2.
3. Connect fixture supply wires to Class 2 wiring - FIG 6.1 & 6.2.
4. Push fixture supply connections completely behind Mounting Bracket - FIG 1.3 & 6.2.

LU1-M2/M4-RT-1000/1000-WD/1400 - REMOTE PHASE CONTROL

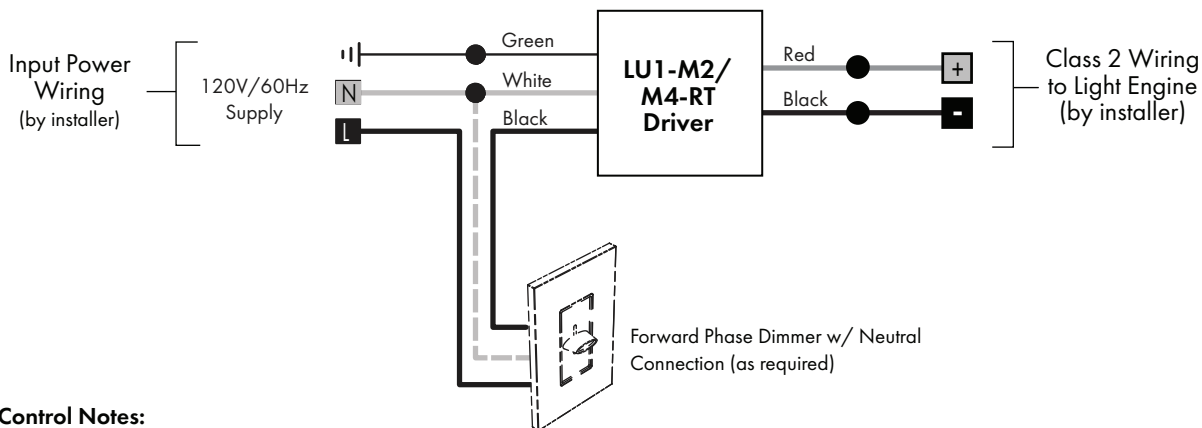

Phase Control Notes:

LU1 drivers are Forward Phase dimmable only.

For compatible dimmers for use with LU1 drivers, contact Lutron LED Center of Excellence at 1.877.346.5338 or LEDs@lutron.com.

FIG 6.1 Wiring Diagram

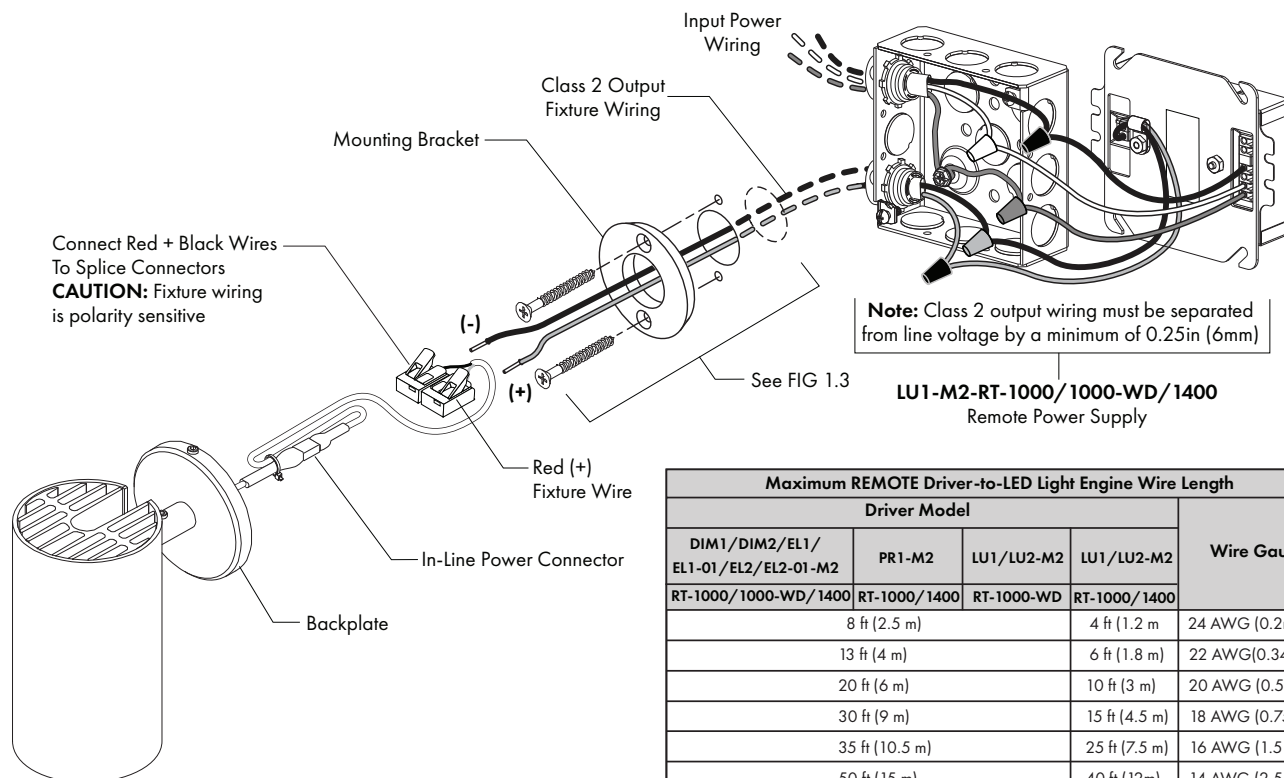

Maximum REMOTE Driver-to-LED Light Engine Wire Length				
Driver Model				Wire Gauge
DIM1/DIM2/EL1/EL1-01/EL2/EL2-01-M2	PR1-M2	LU1/LU2-M2	LU1/LU2-M2	
RT-1000/1000-WD/1400	RT-1000/1400	RT-1000-WD	RT-1000/1400	
	8 ft (2.5 m)		4 ft (1.2 m)	24 AWG (0.2mm ²)
	13 ft (4 m)		6 ft (1.8 m)	22 AWG (0.34mm ²)
	20 ft (6 m)		10 ft (3 m)	20 AWG (0.5 mm ²)
	30 ft (9 m)		15 ft (4.5 m)	18 AWG (0.75 mm ²)
	35 ft (10.5 m)		25 ft (7.5 m)	16 AWG (1.5 mm ²)
	50 ft (15 m)		40 ft (12m)	14 AWG (2.5 mm ²)
	100 ft (30 m)		60 ft (18 m)	12 AWG (4.0 mm ²)

Wire Type: Stranded Class 2 wire (supplied by others)

FIG 6.2 Wire & Install Remote Power Supply

WIRING INSTRUCTIONS - MPT2-RT (continued)

For LU2-M2/M4-RT-1000/1000-WD Remote Dimming Options

Wiring Connections

1. Verify correct power supply model (see label on cover plate), LED type (see label on fixture), wire length and gauge (see chart below) and input requirements (see label on driver) - FIG 7.2.
2. Install & wire remote power supply assembly - FIG 7.1 & 7.2.
3. Connect fixture supply wires to Class 2 wiring - FIG 7.1 & 7.2.
4. Push fixture supply connections completely behind Mounting Bracket - FIG 1.3 & 7.2.

LU2-M2/M4-RT-1000/1000-WD - REMOTE ECOSYSTEM CONTROL

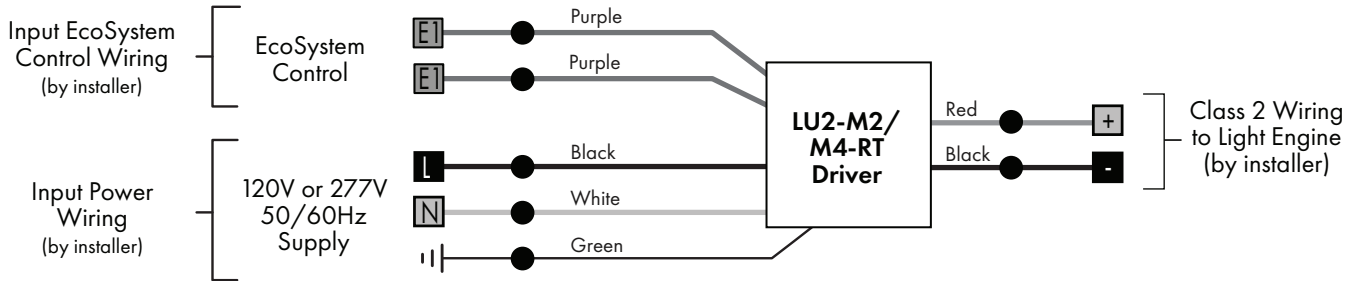

Lutron EcoSystem Control Notes:

Up to 64 LU2 power supplies can be daisy chained per EcoSystem control loop. Maximum control wiring run length is 1000'. For additional information contact LED Center of Excellence at 1.877.346.5338 or LEDs@lutron.com.

FIG 7.1 Wiring Diagram

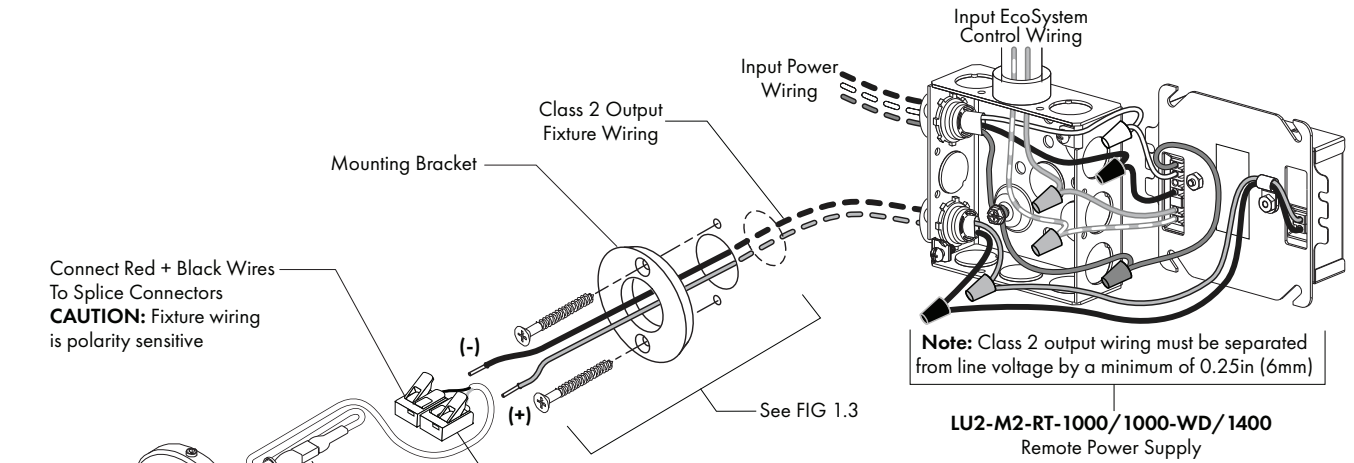

FIG 7.2 Wire & Install Remote Power Supply

Maximum REMOTE Driver-to-LED Light Engine Wire Length				
Driver Model				Wire Gauge
DIM1/DIM2/EL1/EL1-01/EL2/EL2-01-M2	PR1-M2	LU1/LU2-M2	LU1/LU2-M2	
RT-1000/1000-WD/1400	RT-1000/1400	RT-1000-WD	RT-1000/1400	
	8 ft (2.5 m)		4 ft (1.2 m)	24 AWG (0.2mm ²)
	13 ft (4 m)		6 ft (1.8 m)	22 AWG (0.34mm ²)
	20 ft (6 m)		10 ft (3 m)	20 AWG (0.5 mm ²)
	30 ft (9 m)		15 ft (4.5 m)	18 AWG (0.75 mm ²)
	35 ft (10.5 m)		25 ft (7.5 m)	16 AWG (1.5 mm ²)
	50 ft (15 m)		40 ft (12 m)	14 AWG (2.5 mm ²)
	100 ft (30 m)		60 ft (18 m)	12 AWG (4.0 mm ²)
Wire Type: Stranded Class 2 wire (supplied by others)				